

EDI MODEL 2018ECLIP-NC CONFLICT MONITOR

PROGRAMMING DETAIL

(remove jumpers and set switches as shown)

REMOVE DIODE JUMPERS 1-6, 1-9, 1-11, 1-15, 2-6, 2-9, 2-11, 2-13, 2-15, 4-8, 4-14, 4-16, 6-9, 6-11, 6-13, 6-15, 8-14, 8-16, 9-11, 9-13, 9-15, 11-13, 11-15, 13-15, and 14-16.

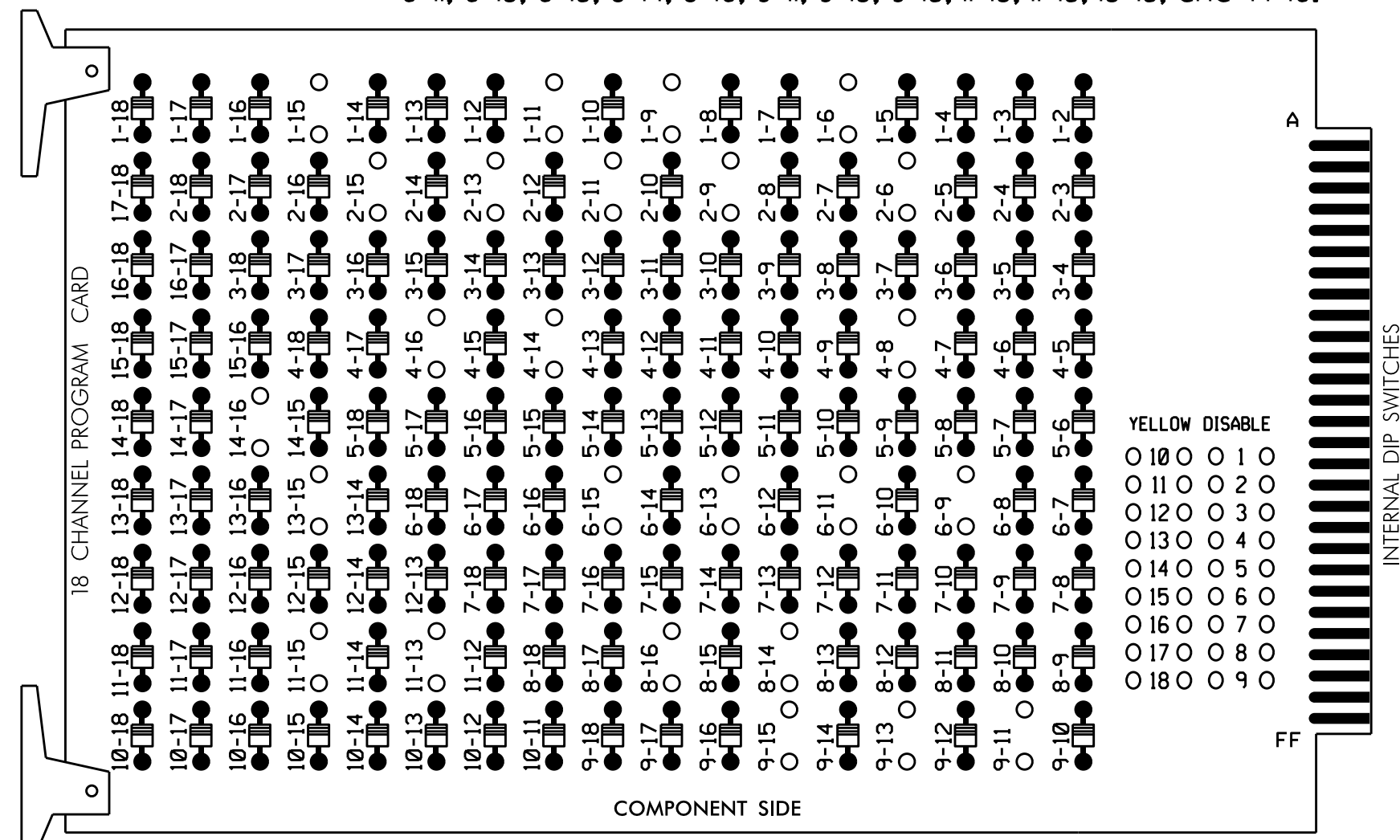

REMOVE JUMPERS AS SHOWN

NOTES:

- Card is provided with all diode jumpers in place. Removal of any jumper allows its channels to run concurrently.
- Ensure jumpers SEL2-SEL5 and SEL9 are present on the monitor board.
- Ensure that Red Enable is active at all times during normal operation.
- Integrate monitor with Ethernet network in cabinet.

■ = DENOTES POSITION OF SWITCH

NOTES

- To prevent "flash-conflict" problems, insert red flash program blocks for all unused vehicle load switches in the output file. The installer shall verify that signal heads flash in accordance with the Signal Plans.
- Program phases 4 and 8 for Dual Entry.
- Enable Simultaneous Gap-Out for all phases.
- Program phases 2 and 6 for Start Up In Green.
- Program phases 2, 4, 6 and 8 for 'STARTUP PED CALL'.
- Program phases 2 and 6 for Yellow Flash, and overlap 1 as Wag Overlaps.
- The cabinet and controller are part of the Asheville Signal System.

EQUIPMENT INFORMATION

CONTROLLER.....2070E
 CABINET.....332 W/ AUX
 SOFTWARE.....ECONOLITE OASIS
 CABINET MOUNT.....BASE
 OUTPUT FILE POSITIONS...18 WITH AUX. OUTPUT FILE
 LOAD SWITCHES USED.....S1,S2,S3,S5,S6,S8,S9,S11,S12,
 AUX S1,AUX S4
 PHASES USED.....1,2,2PED,4,4PED,6,6PED,8,8PED
 OVERLAP "A".....1+2
 OVERLAP "B".....NOT USED
 OVERLAP "C".....6
 OVERLAP "D".....NOT USED

SIGNAL HEAD HOOK-UP CHART

LOAD SWITCH NO.	S1	S2	S3	S4	S5	S6	S7	S8	S9	S10	S11	S12	AUX S1	AUX S2	AUX S3	AUX S4	AUX S5	AUX S6
CMU CHANNEL NO.	1	2	13	3	4	14	5	6	15	7	8	16	9	10	17	11	12	18
PHASE	1	2	2 PED	3	4	4 PED	5	6	6 PED	7	8	8 PED	OLA	OLB	SPARE	OLC	OLD	SPARE
SIGNAL HEAD NO.	11	22,23	P21, P22	NU	41,42	P41, P42	NU	61,62	P61, P62	NU	81,82	P81, P82	11	NU	NU	21	NU	NU
RED		128			101			134			107							
YELLOW	*	129			102			135			108							
GREEN		130			103			136			109							
RED ARROW													A121			A114		
YELLOW ARROW													A122			A115		
FLASHING YELLOW ARROW													A123			A116		
GREEN ARROW	127																	
Hand			113		104			119			110							
Foot			115		106			121			112							

NU = Not Used

* Denotes install load resistor. See load resistor installation detail this sheet.

★ See pictorial of head wiring in detail below.

INPUT FILE POSITION LAYOUT

(front view)

FILE "I"	1	2	3	4	5	6	7	8	9	10	11	12	13	14
U	∅ 1	-ORS	-ORS	-ORS	-ORS	∅ 4	-ORS	-ORS	SYS. DET. SI	-ORS	-ORS	NOT USED	NOT USED	FS
L	1A	-ORS	-ORS	-ORS	-ORS	4A	-ORS	-ORS	NOT USED	-ORS	-ORS	∅ 4 PED	∅ 8 PED	DC ISOLATOR
U	NOT USED	-ORS	-ORS	-ORS	-ORS	NOT USED	-ORS	-ORS	NOT USED	-ORS	-ORS	∅ 4 PED	∅ 8 PED	DC ISOLATOR
L	-ORS	-ORS	-ORS	-ORS	-ORS	8A	-ORS	-ORS	-ORS	-ORS	-ORS	∅ 4 PED	∅ 8 PED	DC ISOLATOR

EX.: 1A, 2A, ETC. = LOOP NO.'S

FS = FLASH SENSE
 ST = STOP TIME

COUNTDOWN PEDESTRIAN SIGNAL OPERATION

Countdown Ped Signals are required to display timing only during Ped Clearance Interval. Consult Ped Signal Module user's manual for instructions on selecting this feature.

INPUT FILE CONNECTION & PROGRAMMING CHART

LOOP NO.	LOOP TERMINAL	INPUT FILE POS.	PIN NO.	INPUT ASSIGNMENT NO.	DETECTOR NO.	NEMA PHASE	CALL	EXTEND	FULL TIME DELAY	STRETCH TIME	DELAY TIME
1A	TB2-1,2	I1U	56	18	1	1	Y	Y			15
4A	TB4-9,10	I6U	41	3	4	4	Y	Y			10
8A	TB5-9,10	J6U	42	4	8	8	Y	Y			10
* S1	TB6-9,10	I9U	60	22	11	SYS					
PED PUSH BUTTONS											
P41,P42	TB8-5,6	I12L	69	31	PED 4	4 PED					
P81,P82	TB8-8,9	I13L	70	32	PED 8	8 PED					

NOTE:
 INSTALL DC ISOLATORS IN INPUT FILE SLOTS 112 AND 113.

* System detector only. Remove the vehicle phase assigned to this detector in the default programming.

FYA SIGNAL WIRING DETAIL

(wire signal heads as shown)

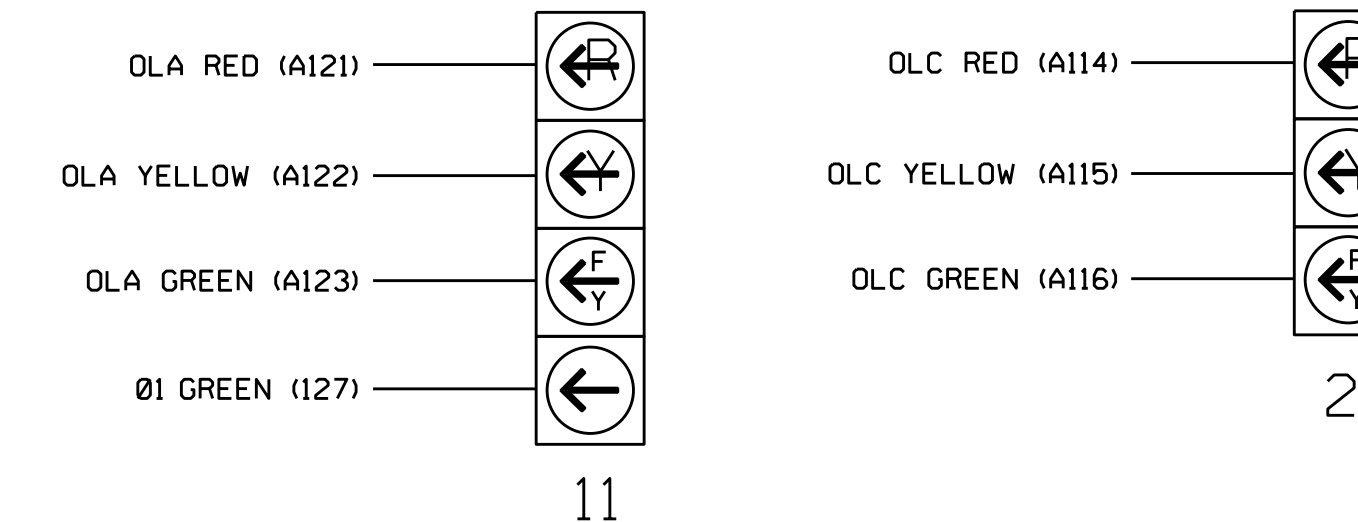

NOTE

The sequence display for signal head 11 requires special logic programming. See sheet 2 for programming instructions.

LOAD RESISTOR INSTALLATION DETAIL

(install resistor as shown below)

VALUE (ohms)	WATTAGE
1.5K - 1.9K	25W (min)
2.0K - 3.0K	10W (min)

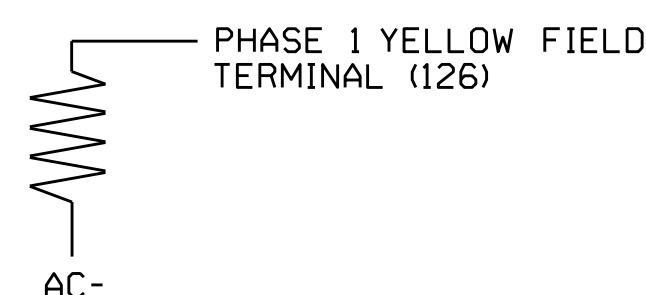

INPUT FILE POSITION LEGEND: J2L

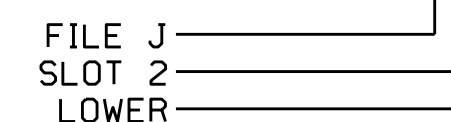

Electrical Detail - Sheet 1 of 2

DOCUMENT NOT CONSIDERED FINAL UNLESS ALL SIGNATURES COMPLETED

Prepared In the Offices of:
 TRANSPORTATION MOBILITY AND SAFETY ADMINISTRATION
 FEDERAL BUREAU OF INVESTIGATION
 Signal Management Section
 750 N. Greenfield Pkwy, Garner, NC 27529

US 19-23 Business (Haywood Road) at NC 191 (Brevard Road)/ Dunwell Avenue

Division 13 Buncombe County Asheville

PLAN DATE: July 2016 REVIEWED BY: BAS

PREPARED BY: S. Armstrong REVIEWED BY:

REVISIONS INIT. DATE

Seal: KEITH M. MINIS, PROFESSIONAL ENGINEER, NO. 036880

Designed by: Keith M. Minis 9/12/2016

SIG. INVENTORY NO. 13-0215