

NOTES

- STIRRUPS IN CAP MAY BE SHIFTED AS NECESSARY TO CLEAR DOWELS.
- ★ INVERT ALTERNATE STIRRUPS.
- GALVANIZE THE TOP OF EACH INTERIOR BENT PILE A MINIMUM OF 26 FEET, GALVANIZE IN ACCORDANCE WITH SECTION 1076 OF THE STANDARD SPECIFICATIONS.

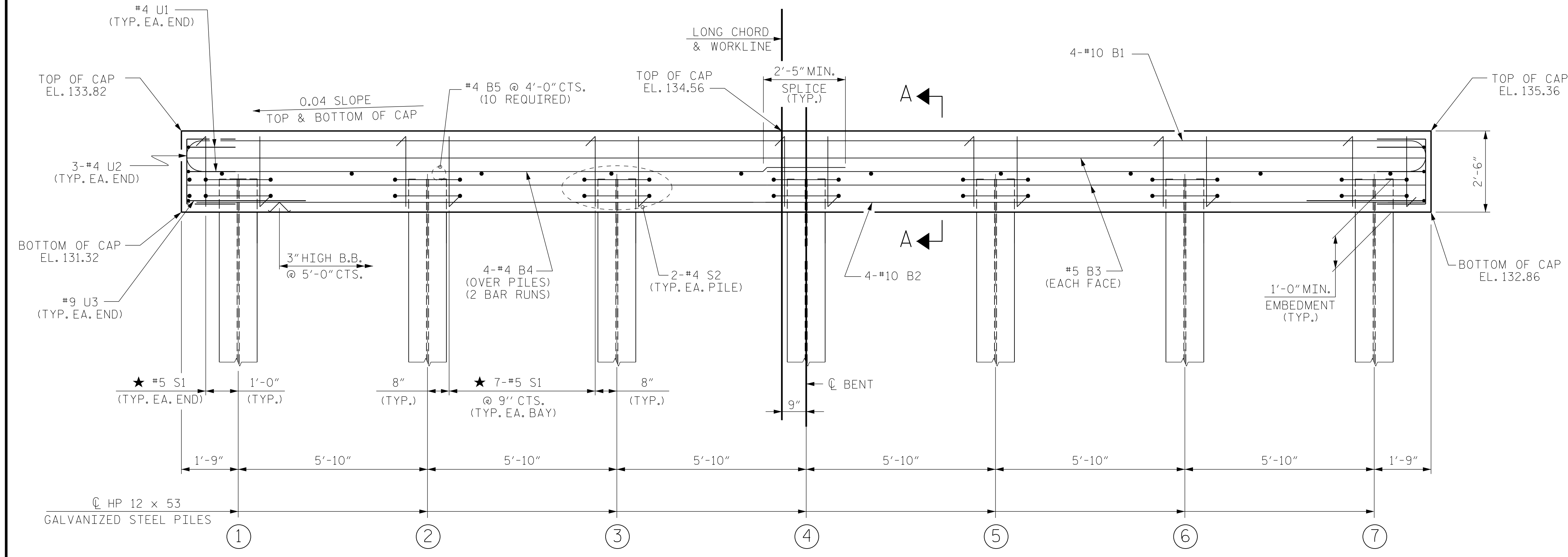
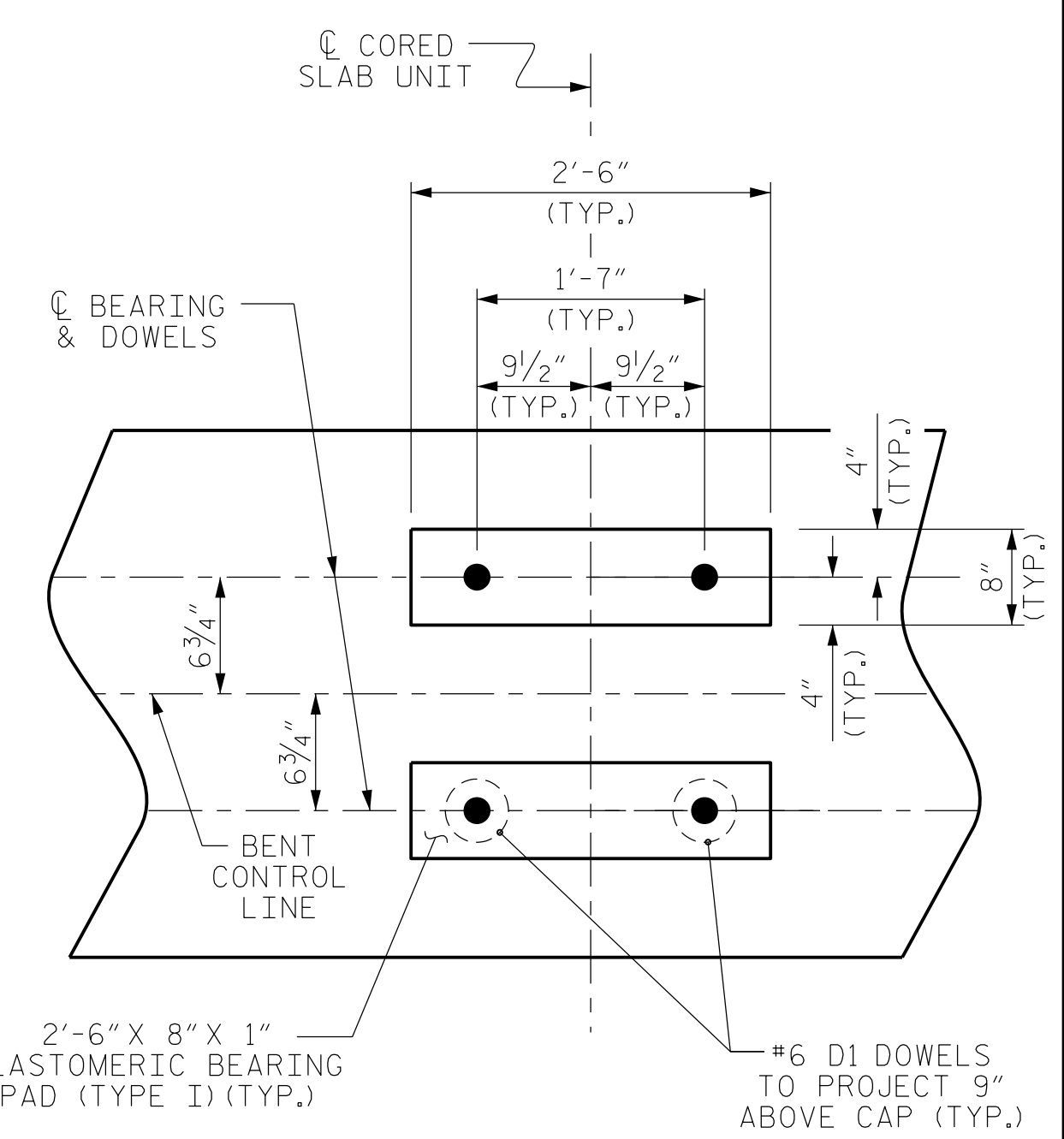
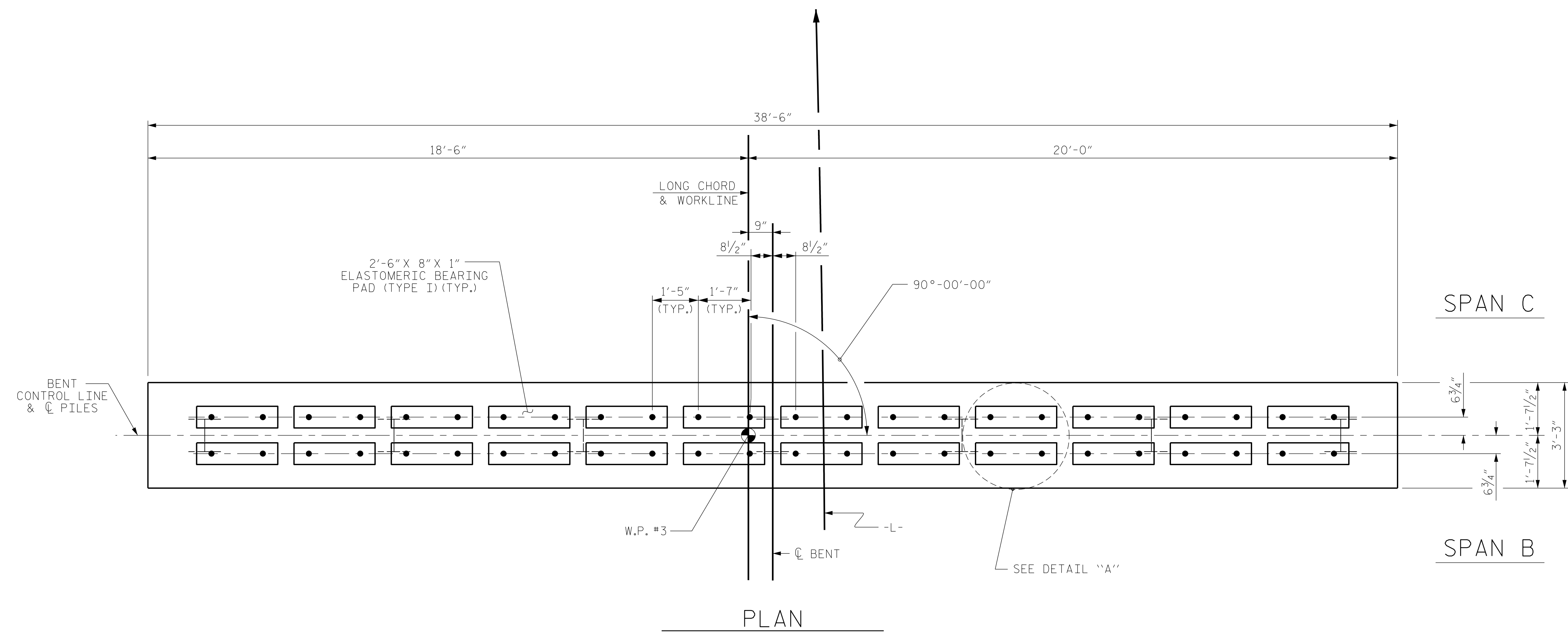

TOP OF PILE ELEVATIONS	
①	132.41
②	132.64
③	132.88
④	133.11
⑤	133.34
⑥	133.58
⑦	133.81

PROJECT NO. B-5333
ROBESON COUNTY
 STATION: 37+28.50 -L-

SHEET 2 OF 3 BRIDGE NO. 174

Dewberry
 2610 WYCLIFF ROAD
 SUITE 410
 RALEIGH, NC 27607
 PHONE: 919.881.9339
 NC COA No. F-0929

SEAL
 032076
 ENGINEER
 JENNIFER R. McROY
 12/9/2016

DocuSigned by:
 Jennifer R. McRoy
 E1140791288475

STATE OF NORTH CAROLINA
DEPARTMENT OF TRANSPORTATION
 RALEIGH

SUBSTRUCTURE
BENT No. 2

REVISIONS					
No.	BY:	DATE:	No.	BY:	DATE:
1			3		
2			4		

SHEET No.
S02-20
 TOTAL SHEETS
 23

12/9/2016 8:50:33 AM BENT2.dgn
 USER: jrmr04

DRAWN BY : MTB DATE : 04/16
 CHECKED BY : JRM DATE : 04/16