

NOTES

- STIRRUPS IN CAP MAY BE SHIFTED AS NECESSARY TO CLEAR DOWELS.
- ★ INVERT ALTERNATE STIRRUPS.
- GALVANIZE THE TOP OF EACH INTERIOR BENT PILE A MINIMUM OF 23 FEET, GALVANIZE IN ACCORDANCE WITH SECTION 1076 OF THE STANDARD SPECIFICATIONS.

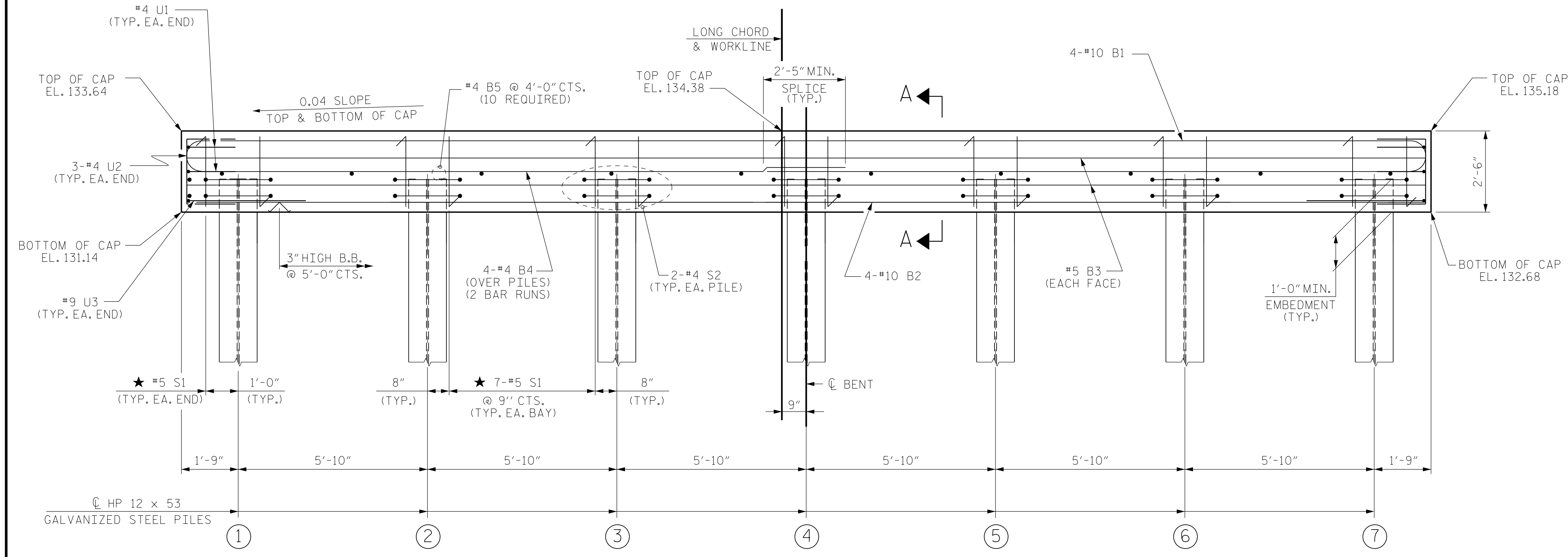
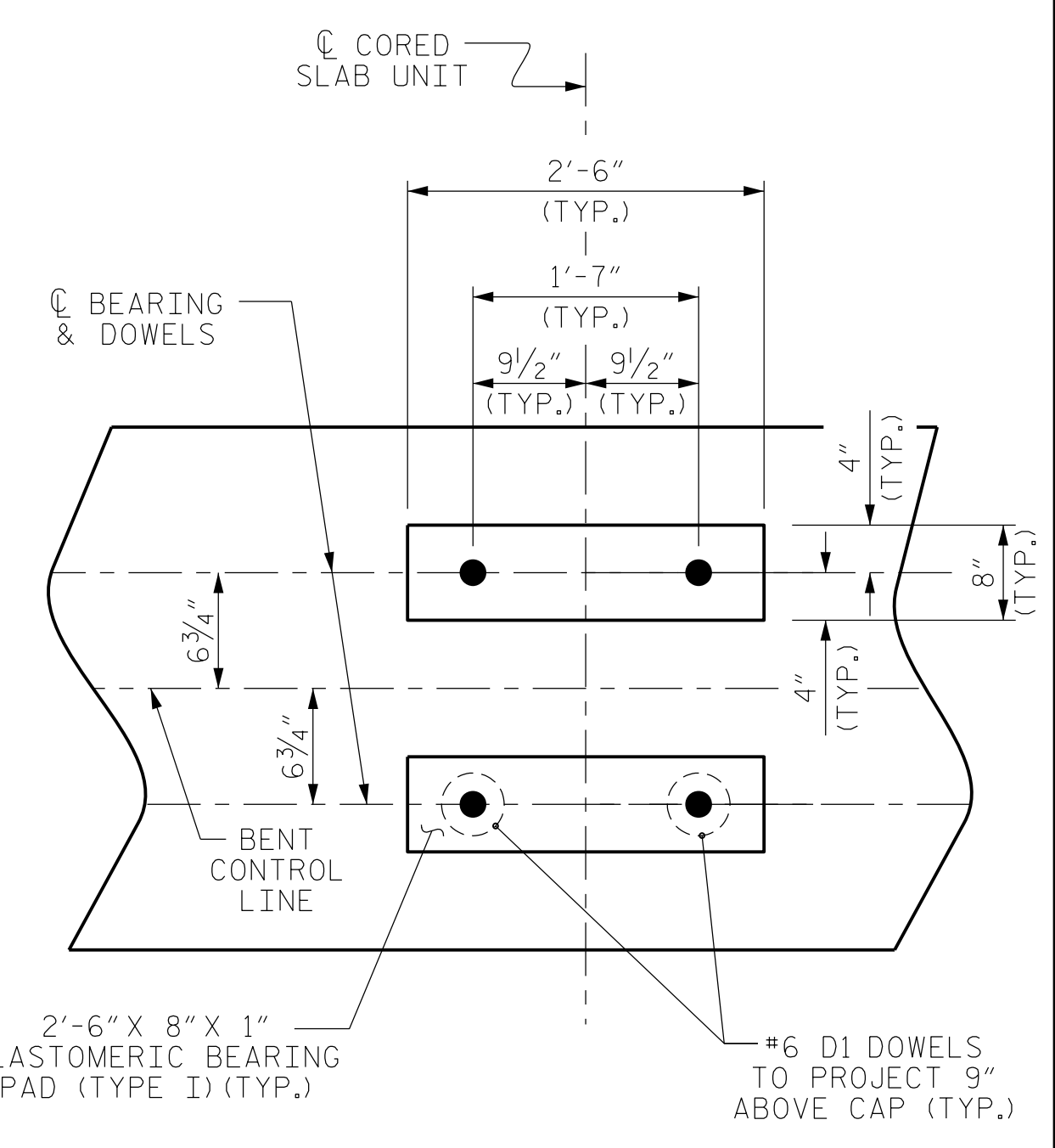
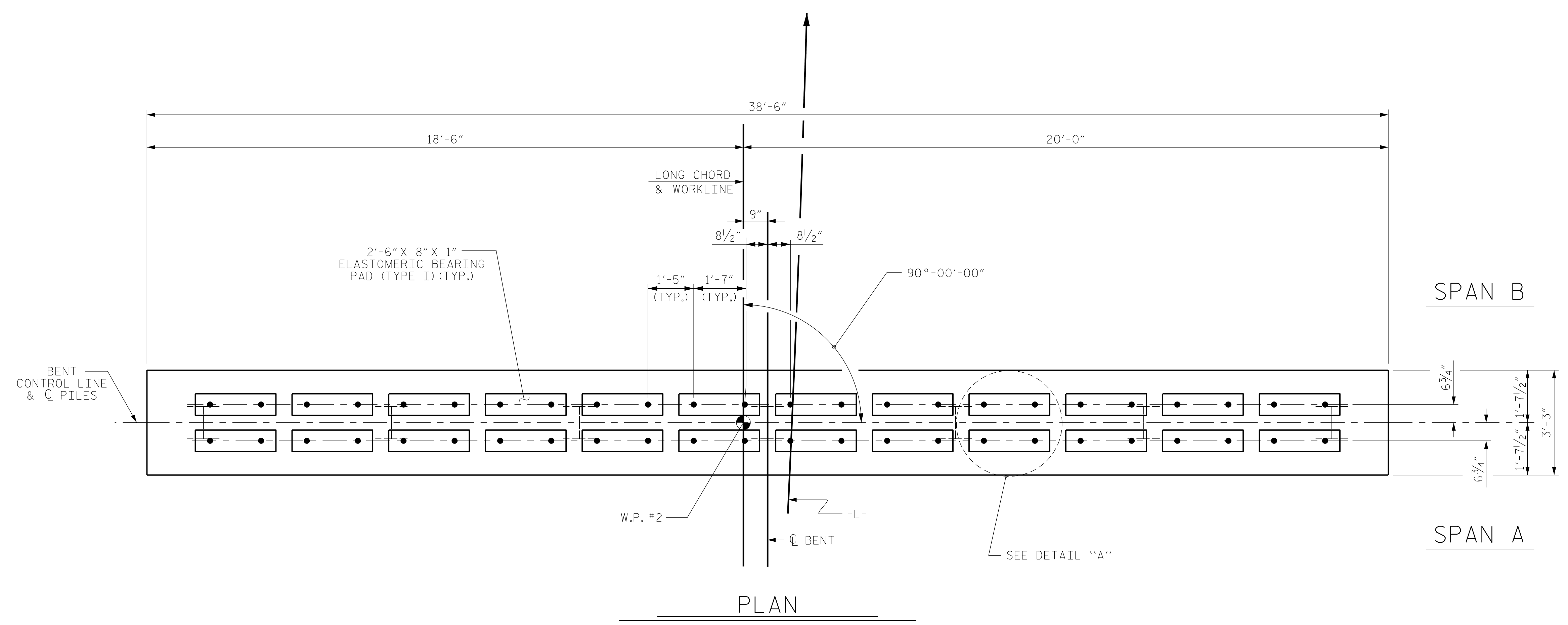

TOP OF PILE ELEVATIONS	
①	132.23
②	132.46
③	132.70
④	132.93
⑤	133.16
⑥	133.40
⑦	133.63

PROJECT NO. B-5333
ROBESON COUNTY
 STATION: 37+28.50 -L-

SHEET 1 OF 3 BRIDGE NO. 174

Dewberry
 2610 WYCLIFF ROAD
 SUITE 410
 RALEIGH, NC 27607
 PHONE: 919.881.9339
 NC COA No. F-0929

SEAL
 032076
 ENGINEER
 JENNIFER R. MCKAY
 12/9/2016

DocuSigned by:
 Jennifer R. McKay
 E1114C791288475

STATE OF NORTH CAROLINA
DEPARTMENT OF TRANSPORTATION
 RALEIGH

SUBSTRUCTURE
BENT No. 1

REVISIONS					
No.	BY:	DATE:	No.	BY:	DATE:
1			3		
2			4		

SHEET No.
S02-19
 TOTAL SHEETS
 23

DRAWN BY : MTB DATE : 04/16
 CHECKED BY : JRM DATE : 04/16

12/9/2016 8:49:58 AM BENT1.dgn
 USER: jrm204