

**NOTES**

STIRRUPS IN CAP MAY BE SHIFTED AS NECESSARY TO CLEAR DOWELS.

★ INVERT ALTERNATE STIRRUPS.

GALVANIZE THE TOP OF EACH INTERIOR BENT PILE A MINIMUM OF 29 FEET. GALVANIZE IN ACCORDANCE WITH SECTION 1076 OF THE STANDARD SPECIFICATIONS.

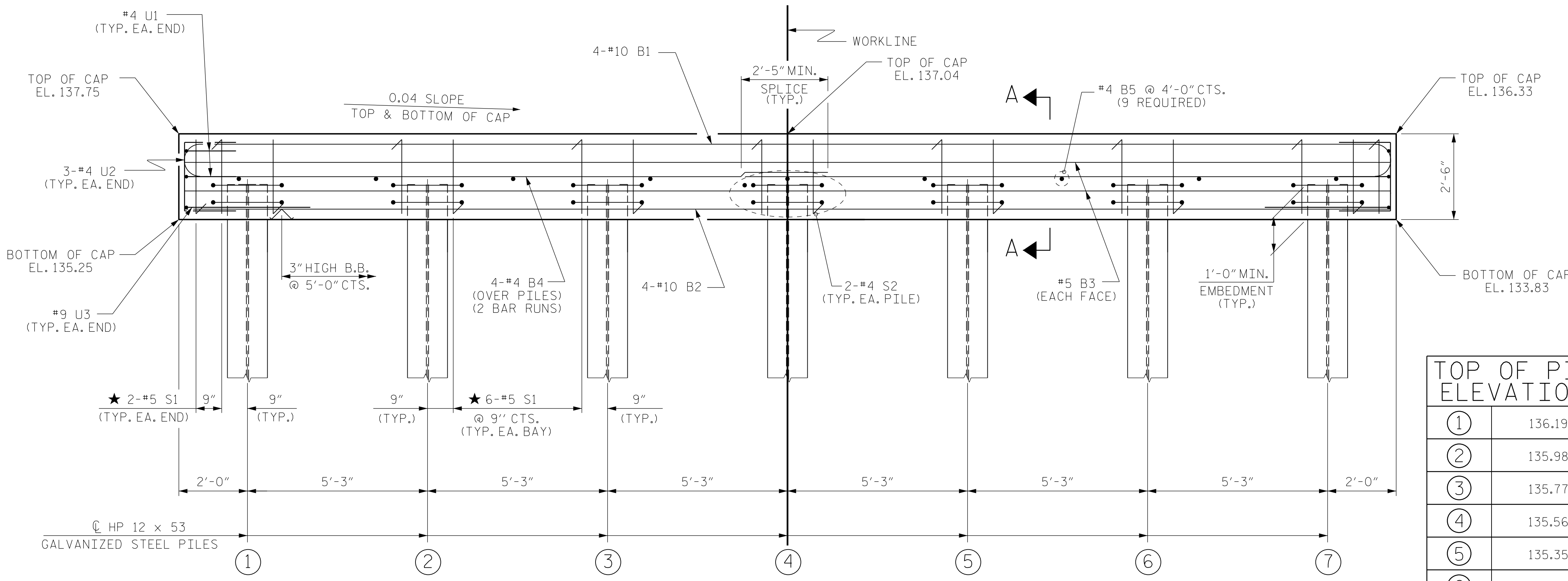
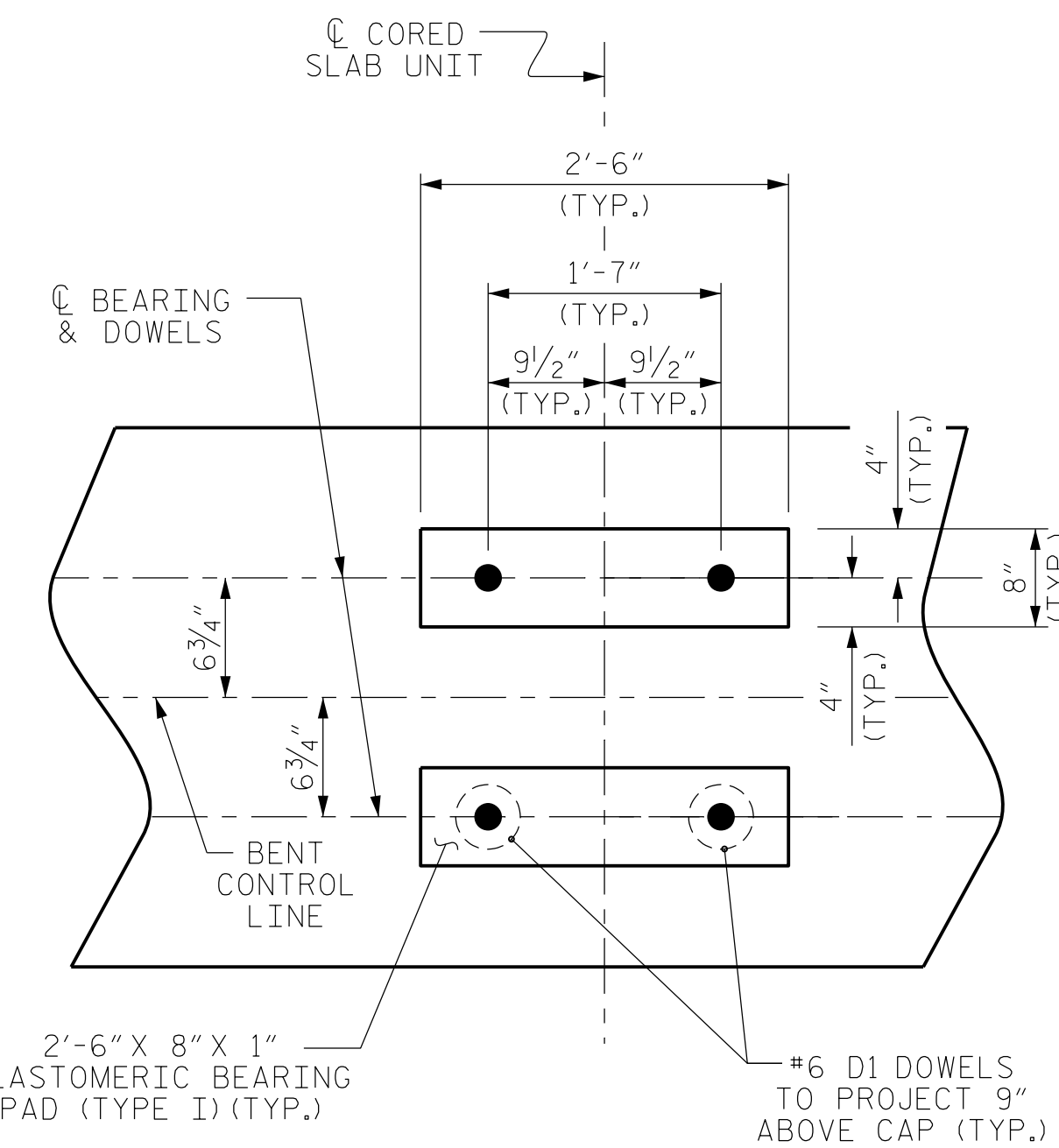
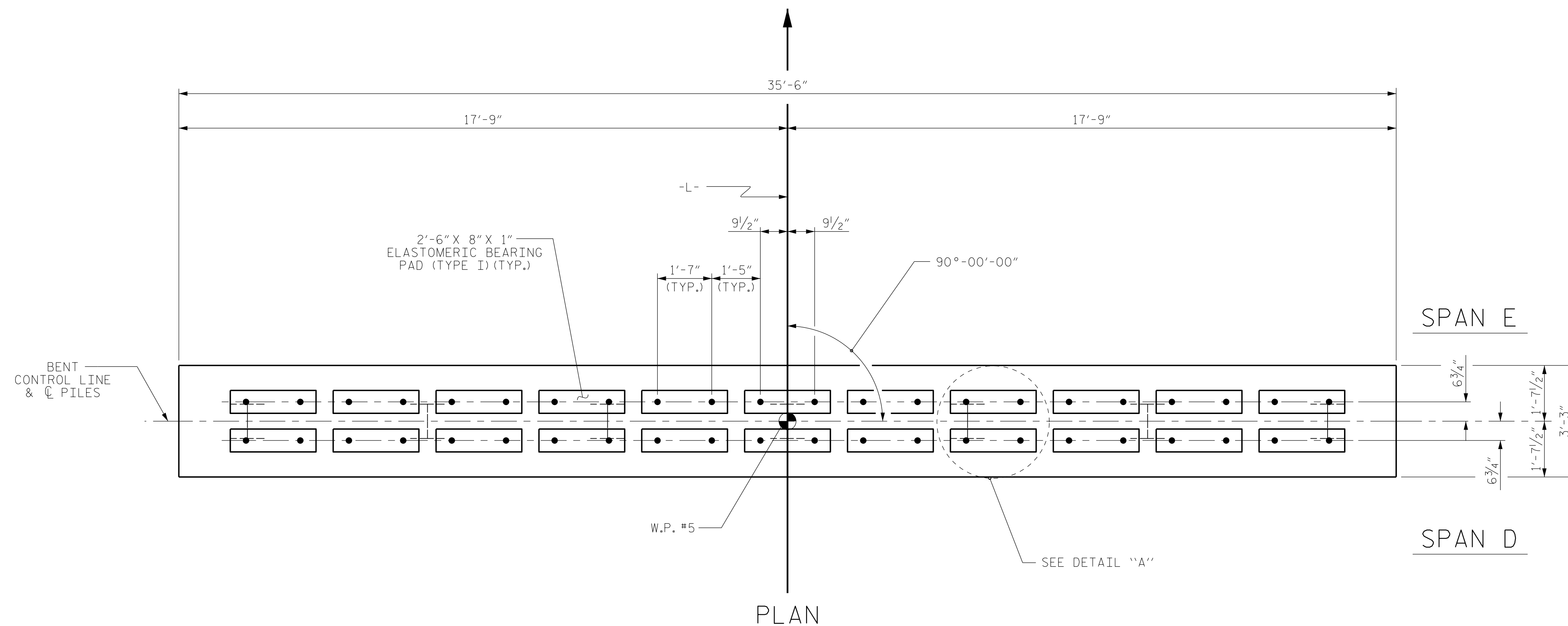

TOP OF PILE ELEVATIONS	
①	136.19
②	135.98
③	135.77
④	135.56
⑤	135.35
⑥	135.14
⑦	134.93

**DETAIL 'A'**  
(DIMENSIONS ARE TYPICAL EACH BEARING)

PROJECT NO. B-5333  
ROBESON COUNTY  
 STATION: 21+57.00 -L-

SHEET 1 OF 2 BRIDGE NO. 173

**Dewberry**  
 2610 WYCLIFF ROAD  
 SUITE 410  
 RALEIGH, NC 27607  
 PHONE: 919.881.9939  
 NC COA No. F-0929

SEAL  
 032076  
 ENGINEER  
 JENNIFER R. MCDY

DocuSigned by:  
 Jennifer R. Mcdy 6/6/2016

STATE OF NORTH CAROLINA  
**DEPARTMENT OF TRANSPORTATION**  
 RALEIGH

SUBSTRUCTURE  
 BENT No. 4

REVISIONS					
No.	BY:	DATE:	No.	BY:	DATE:
1			3		
2			4		

SHEET No.  
**S01-21**  
 TOTAL SHEETS  
 24

6/2/2016 8:56:16 AM 173\_BENT 4-1.dgn USER: mcdy

DRAWN BY : MTB DATE : 04/16  
 CHECKED BY : JRM DATE : 04/16

**ELEVATION**  
 FOR SECTION A-A, SEE SHEET 2 OF 2