

EXISTING JOINT

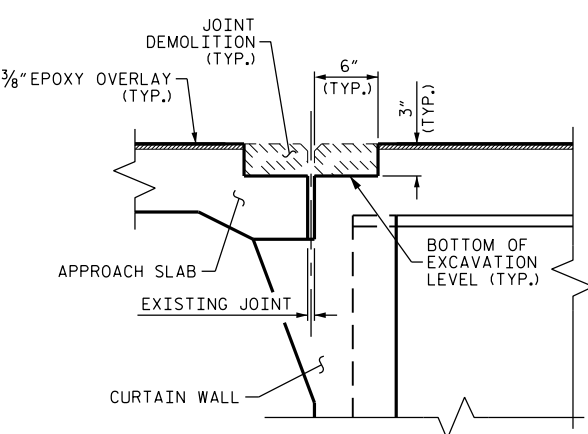

MINIMUM EXISTING JOINT DEMOLITION

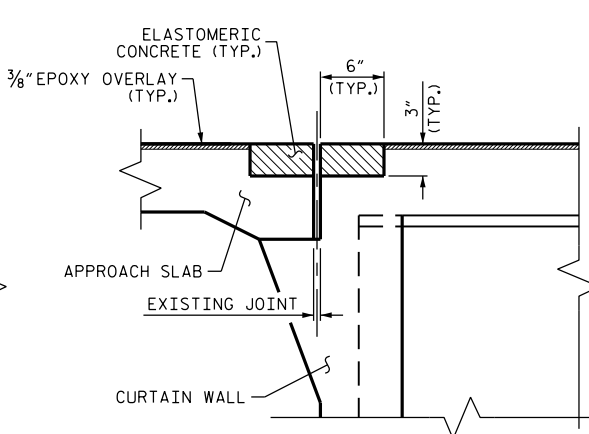

PROPOSED PRE-SAWED JOINT

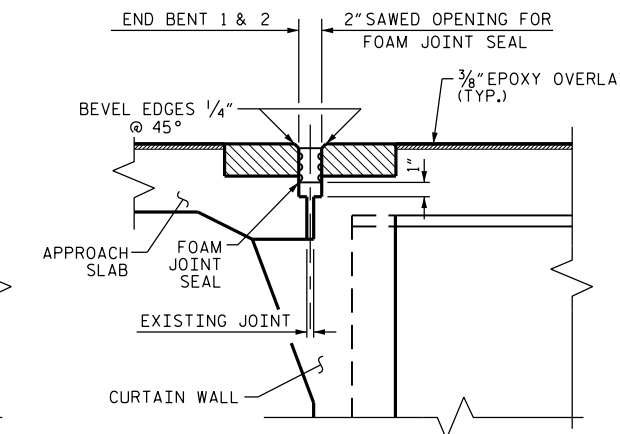

PROPOSED FOAM JOINT SEAL

SECTION A-A

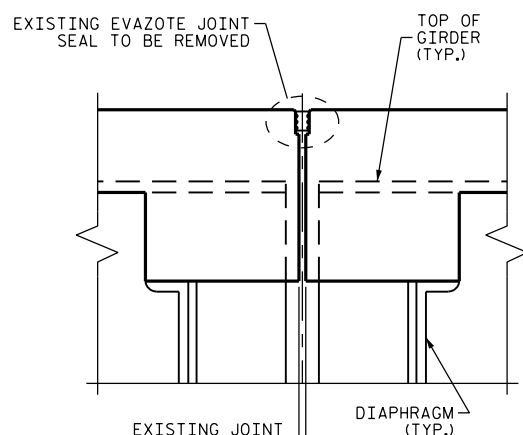

EXISTING JOINT

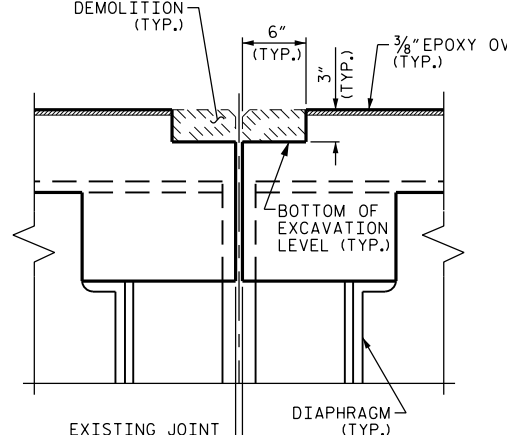

MINIMUM EXISTING JOINT DEMOLITION

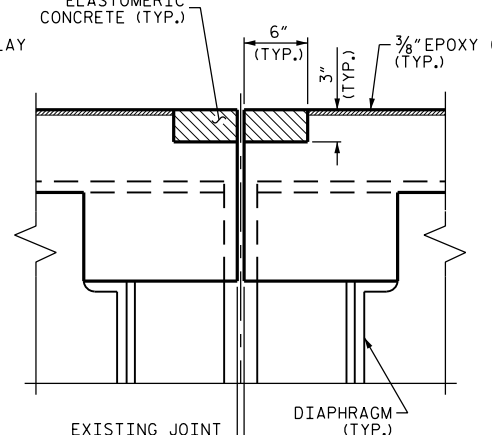

PROPOSED PRE-SAWED JOINT

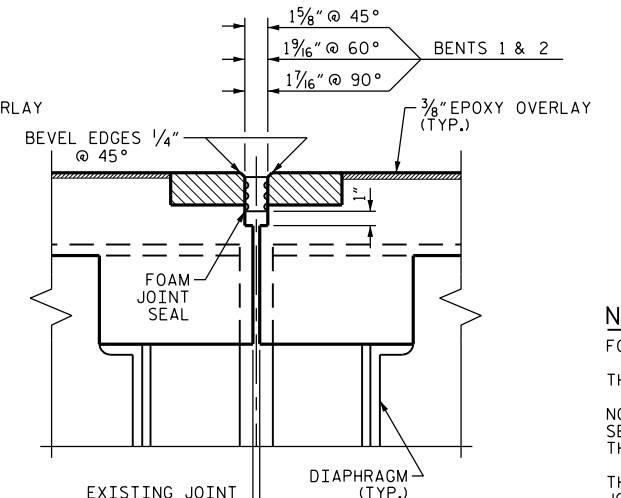

PROPOSED FOAM JOINT SEAL

SECTION B-B

ELASTOMERIC CONCRETE		
END BENT 1	12.1	(CU. FT.)
BENT 1	12.1	(CU. FT.)
BENT 2	12.1	(CU. FT.)
END BENT 2	12.1	(CU. FT.)
* TOTAL	48.4	(CU. FT.)

* BASED ON THE MINIMUM BLOCKOUT SHOWN.

NOTES:
 FOR FOAM JOINT SEALS, SEE SPECIAL PROVISIONS.
 THE INSTALLED FOAM JOINT SEAL SHALL BE WATER TIGHT.
 NOMINAL UNCOMPRESSED SEAL WIDTH OF FOAM JOINT SEAL SHALL BE 2 1/2" AT THE END BENTS AND 2" AT THE BENTS.
 THE CONTRACTOR WILL NOT BE PERMITTED TO FORM THE JOINTS IN LIEU OF SAWING THE JOINT.
 FOR ELASTOMERIC CONCRETE, SEE SPECIAL PROVISIONS.

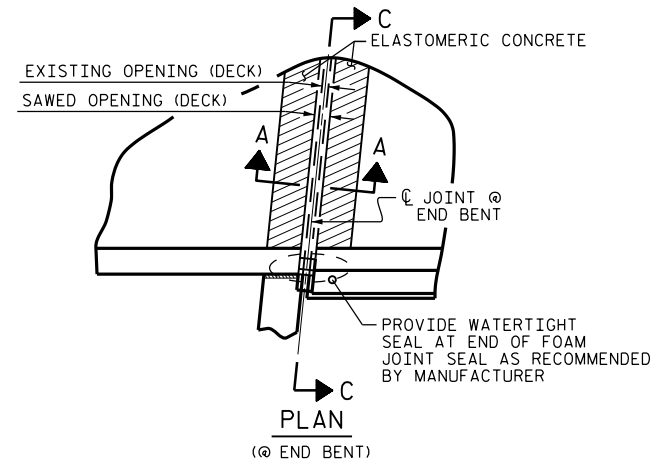

PLAN (@ END BENT)

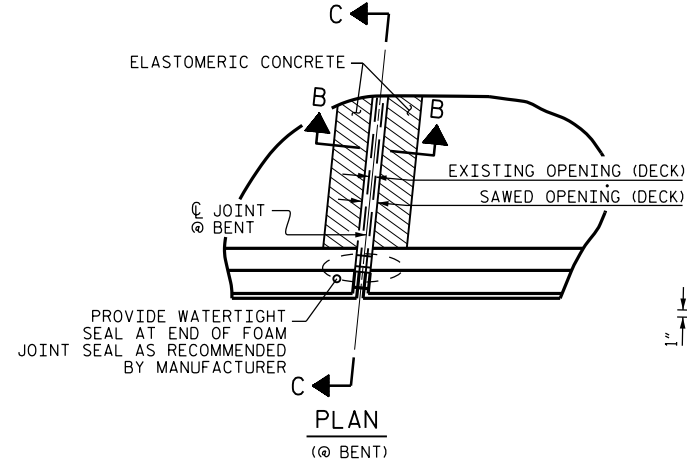

PLAN (@ BENT)

JOINT SEAL DETAILS

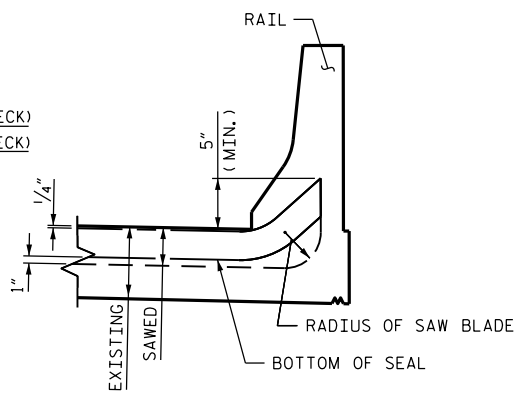

SECTION C-C

PROJECT NO. I-5809
McDOWELL COUNTY
 BRIDGE NO. 138

DocuSigned by:
John A. Yannaccone
 NORTH CAROLINA
 PROFESSIONAL SEAL
 32492
 JOHN A. YANNACCONI
 ENGINEER

9/27/2016

STATE OF NORTH CAROLINA
 DEPARTMENT OF TRANSPORTATION
 RALEIGH
 JOINT DETAILS

DRAWN BY : W.F. PARKER DATE : 05/16
 CHECKED BY : J.P. ADAMS DATE : 6/20/16

REVISIONS						SHEET NO.
NO.	BY:	DATE:	NO.	BY:	DATE:	S-6
1			3			TOTAL SHEETS
2			4			68