

EDI MODEL 2018ECLIP-NC CONFLICT MONITOR PROGRAMMING DETAIL

(remove jumpers and set switches as shown)

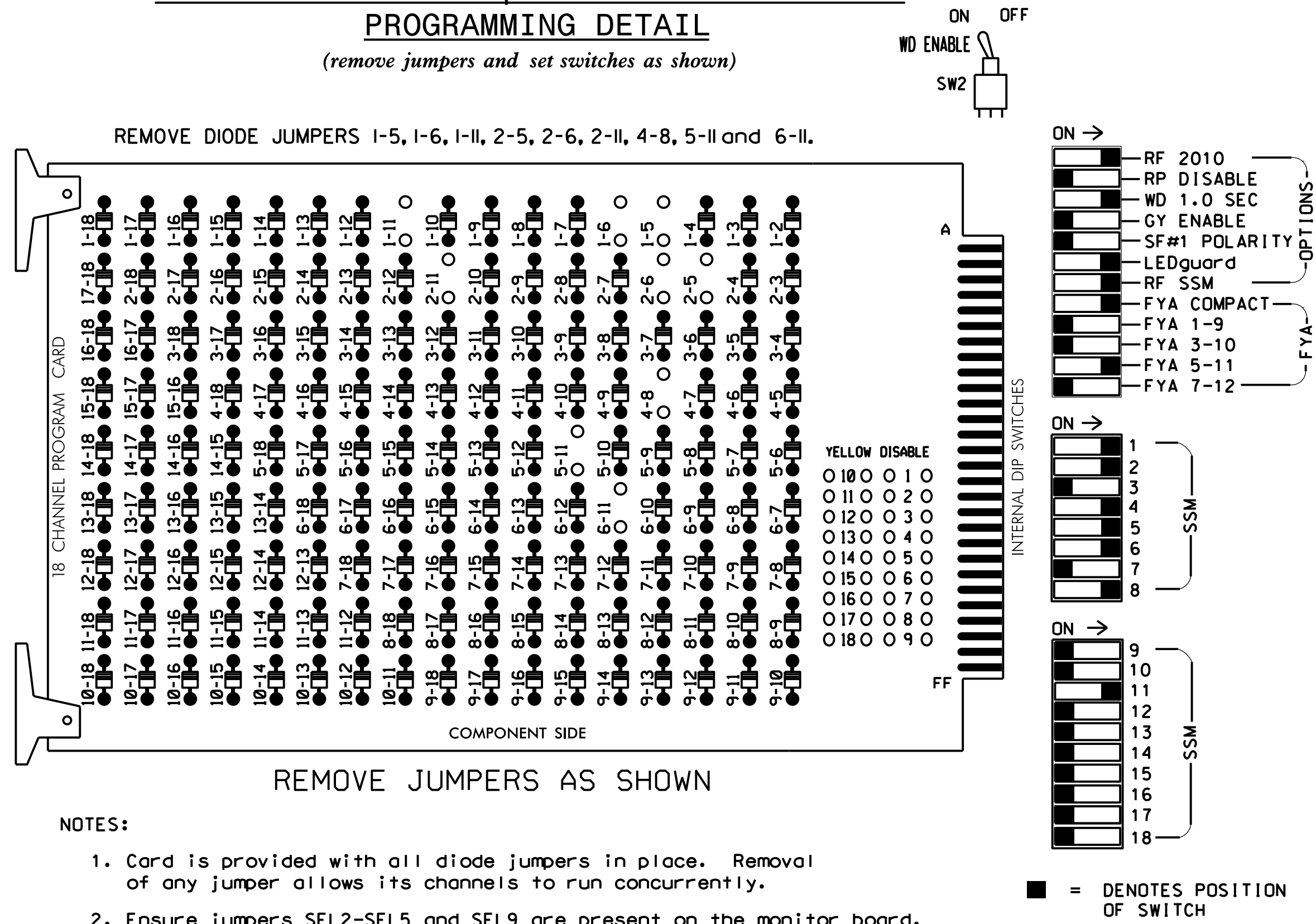

NOTES:

- Card is provided with all diode jumpers in place. Removal of any jumper allows its channels to run concurrently.
- Ensure jumpers SEL2-SEL5 and SEL9 are present on the monitor board.
- Ensure that Red Enable is active at all times during normal operation.
- Integrate monitor with Ethernet network in cabinet.

NOTES

- To prevent "flash-conflict" problems, insert red flash program blocks for all unused vehicle load switches in the output file. The installer shall verify that signal heads flash in accordance with the Signal Plans.
- Program phases 4 and 8 for Dual Entry.
- Enable Simultaneous Gap-Out for all phases.
- Program phases 2 and 6 for Yellow Flash.
- Program controller to start up in phase 2 Green and 6 Green.
- The cabinet and controller are part of the Fayetteville Signal System.

EQUIPMENT INFORMATION

CONTROLLER.....2070E
 CABINET.....332 W/AUX
 SOFTWARE.....ECONOLITE ASC/3-2070
 CABINET MOUNT.....BASE
 OUTPUT FILE POSITIONS...18 WITH AUX. OUTPUT FILE
 LOAD SWITCHES USED.....S1,S2,S5,S7,S8,S11,AUX S4
 PHASES USED.....1,2,4,5,6,8
 OVERLAP "A".....NOT USED
 OVERLAP "B".....NOT USED
 OVERLAP "C".....*
 OVERLAP "D".....NOT USED
 * See overlap programming detail on sheet 2

SIGNAL HEAD HOOK-UP CHART

LOAD SWITCH NO.	S1	S2	S3	S4	S5	S6	S7	S8	S9	S10	S11	S12	AUX S1	AUX S2	AUX S3	AUX S4	AUX S5	AUX S6	
CNU CHANNEL NO.	1	2	13	3	4	14	5	6	15	7	8	16	9	10	17	11	12	18	
PHASE	1	2	2 PED	3	4	4 PED	5	6	6 PED	7	8	8 PED	OLA	OLB	SPARE	OLC	OLD	SPARE	
SIGNAL HEAD NO.	11	21,22	NU	NU	41,42	NU	51*	61,62	NU	NU	81,82	NU	NU	NU	NU	51*	NU	NU	
RED		128			101			134			107								
YELLOW		129			102		*	135			108								
GREEN		130			103			136			109								
RED ARROW	125																	A114	
YELLOW ARROW	126																		A115
FLASHING YELLOW ARROW																			A116
GREEN ARROW	127							133											

NU = Not Used

* Denotes install load resistor. See load resistor installation detail this sheet.

* See pictorial of head wiring in detail this sheet.

INPUT FILE POSITION LAYOUT

(front view)

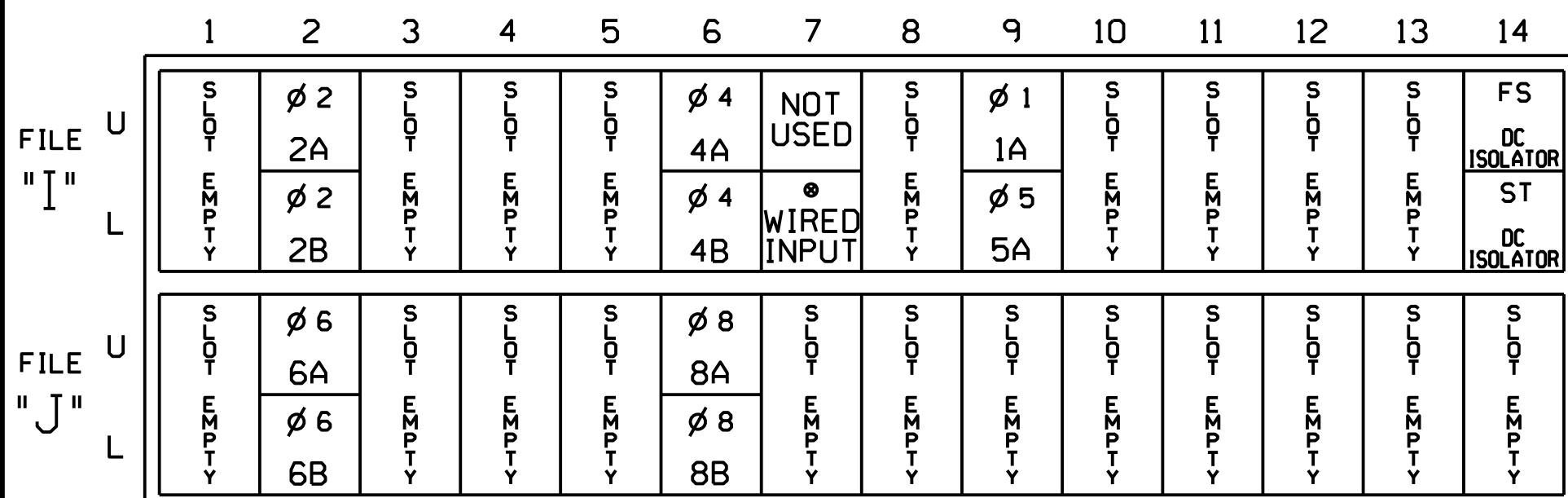

EX.: 1A, 2A, ETC. = LOOP NO.'S

* Wired Input - Do not populate slot with detector card

FS = FLASH SENSE
 ST = STOP TIME

INPUT FILE CONNECTION & PROGRAMMING CHART

LOOP NO.	LOOP TERMINAL	INPUT FILE POS.	PIN NO.	DETECTOR NO.	NEMA PHASE	EXTEND TIME	DELAY TIME	DETECTOR TYPE
1A	TB6-9,10	I9U	60	11	1			S
2A	TB2-5,6	I2U	39	2	2			S
2B	TB2-7,8	I2L	43	12	2			S
4A	TB4-9,10	I6U	41	4	4		3	S
4B	TB4-11,12	I6L	45	14	4			S
5A	TB6-11,12	I9L	62	13	5		15	S
	TB6-3,4	I7L	78	44	2		3	G
6A	TB3-5,6	J2U	40	6	6			S
6B	TB3-7,8	J2L	44	16	6			S
8A	TB5-9,10	J6U	42	8	8		3	S
8B	TB5-11,12	J6L	46	18	8			S

* Add jumper from I7-W to I9-W.

INPUT FILE POSITION LEGEND: J2L

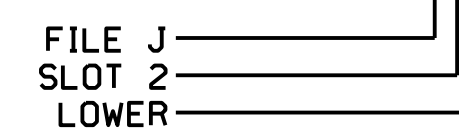

FYA SIGNAL WIRING DETAIL

(wire signal heads as shown)

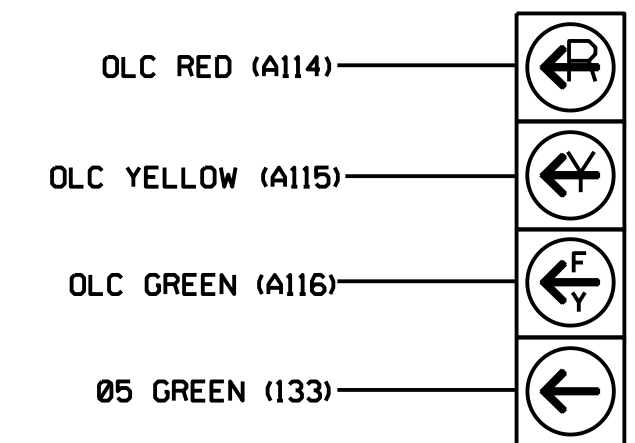

51

LOAD RESISTOR INSTALLATION DETAIL

(install resistors as shown)

VALUE (ohms)	WATTAGE
1.5K - 1.9K	25W (min)
2.0K - 3.0K	10W (min)

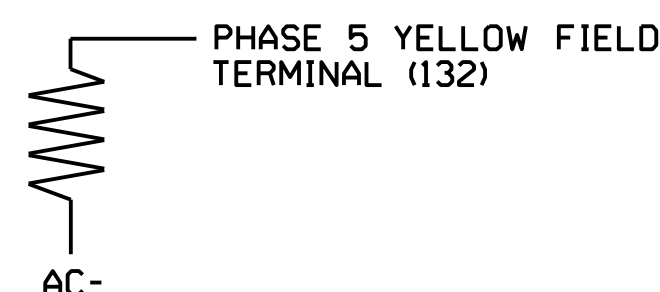

THIS ELECTRICAL DETAIL IS FOR THE SIGNAL DESIGN: C002
 DESIGNED: NOVEMBER 2016
 SEALED: 11/17/2016
 REVISED:

Electrical Detail Sheet 1 of 2

Prepared In the Offices of

 Hatch Mott MacDonald
 PO Box 700
 Fayetteville, NC 27526
 www.hatchmott.com

Seal of Russell W. Thompson, Professional Engineer, License No. 032711, State of North Carolina.

CUMBERLAND COUNTY
 CAIN ROAD AT ROGERS DRIVE
 DIV 06
 PLAN DATE: NOVEMBER 2016 REVIEWED BY: RWT
 PREPARED BY: BLR REVIEWED BY:
 REVISIONS: INIT. DATE
 DocuSigned by: Russell W. Thompson 11/21/2016
 SIGNATURE DATE
 SIG. INVENTORY NO. C002