

EDI MODEL 2018EClip-NC CONFLICT MONITOR

PROGRAMMING DETAIL

(remove jumpers and set switches as shown)

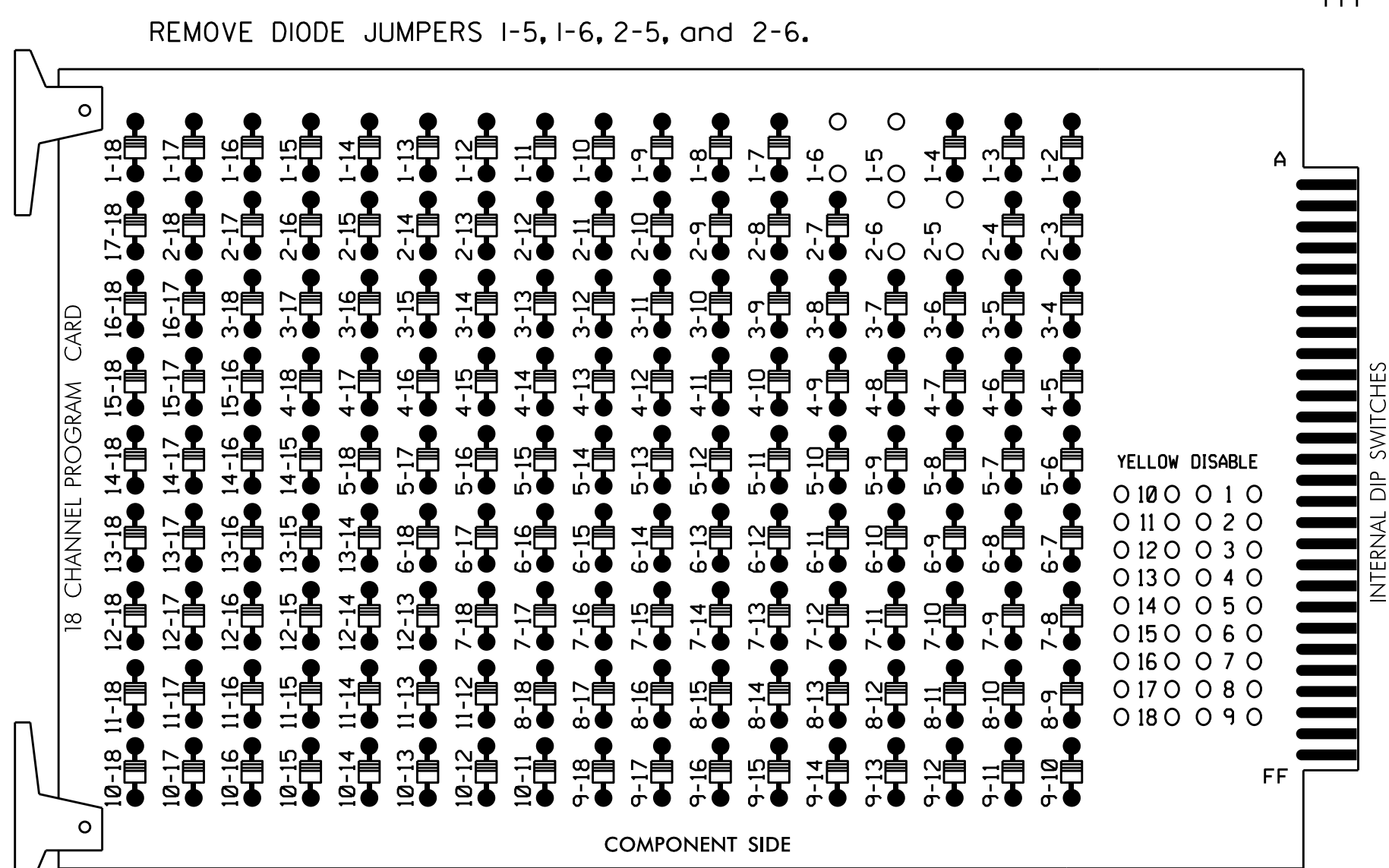

NOTES:

1. Card is provided with all diode jumpers in place. Removal of any jumper allows its channels to run concurrently.
2. Ensure jumpers SEL2-SEL5 and SEL9 are present on the monitor board.
3. Ensure that Red Enable is active at all times during normal operation.
4. Integrate monitor with Ethernet network in cabinet.

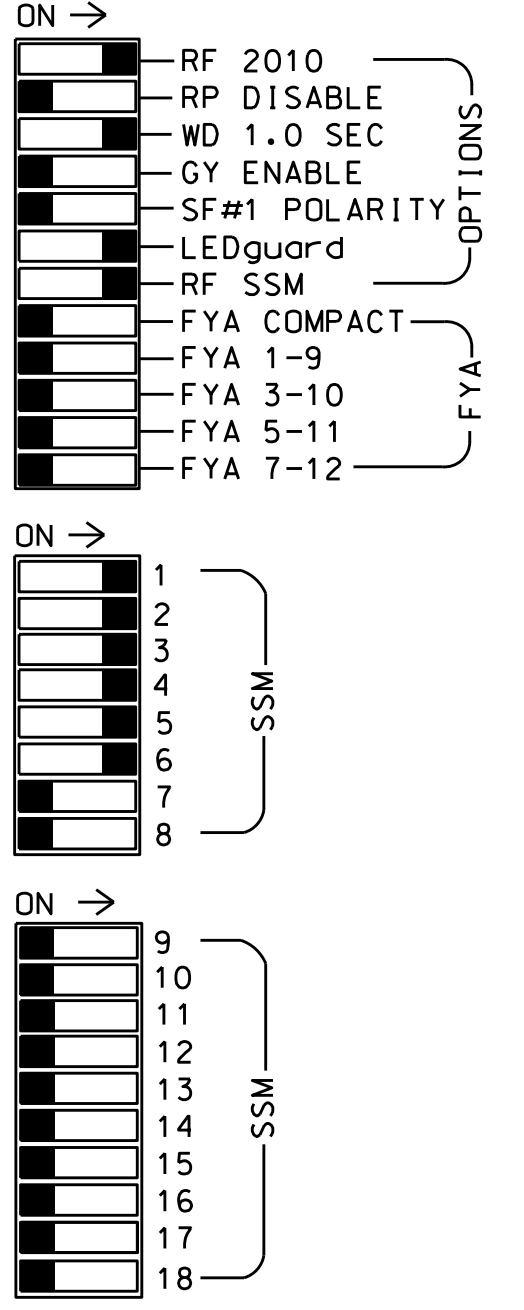

SIGNAL HEAD HOOK-UP CHART

LOAD SWITCH NO.	S1	S2	S3	S4	S5	S6	S7	S8	S9	S10	S11	S12	AUX S1	AUX S2	AUX S3	AUX S4	AUX S5	AUX S6
CMU CHANNEL NO.	1	2	13	3	4	14	5	6	15	7	8	16	9	10	17	11	12	18
PHASE	1	2	2 PED	3	4	4 PED	5	6	6 PED	7	8	8 PED	OLA	OLB	SPARE	OLC	OLD	SPARE
SIGNAL HEAD NO.	11	21,22	NU	31,32	33,34	62	22	41	42	NU	51	61,62	NU	NU	NU	NU	NU	NU
RED		128		116		101	101		134									
YELLOW		129		117		102	102		135									
GREEN		130		118		103	103		136									
RED ARROW	125			116					131									
YELLOW ARROW	126			117		117	102		132									
GREEN ARROW	127			118		118	103	103	133									

NU = Not Used

EQUIPMENT INFORMATION

CONTROLLER.....2070E
 CABINET.....332 W/AUX
 SOFTWARE.....ECONOLITE ASC/3-2070
 CABINET MOUNT.....BASE
 OUTPUT FILE POSITIONS...18 WITH AUX. OUTPUT FILE
 LOAD SWITCHES USED.....S1,S2,S4,S5,S7,S8
 PHASES USED.....1,2,3,4,5,6
 OVERLAPS.....NONE

NOTES

1. To prevent "flash-conflict" problems, insert red flash program blocks for all unused vehicle load switches in the output file. The installer shall verify that signal heads flash in accordance with the Signal Plans.
2. Enable Simultaneous Gap-Out for all phases.
3. Program phases 2 and 6 for volume density operation.
4. Program controller to start up in phase 2 Green and 6 Green.
5. The cabinet and controller are part of the Fayetteville Signal System.

INPUT FILE POSITION LAYOUT

(front view)

FILE	1	2	3	4	5	6	7	8	9	10	11	12	13	14
U	∅ 1	∅ 2	∅ 3	∅ 4	∅ 5	∅ 6	∅ 7	∅ 8	∅ 9	∅ 10	∅ 11	∅ 12	∅ 13	∅ 14
I	1A	2A	3A	4A	5A	6A	7A	8A	9A	10A	11A	12A	13A	14A
L	NOT USED	2B	3B	4B	5B	6B	7B	8B	9B	10B	11B	12B	13B	14B
U	∅ 5	∅ 6	∅ 7	∅ 8	∅ 9	∅ 10	∅ 11	∅ 12	∅ 13	∅ 14	∅ 15	∅ 16	∅ 17	∅ 18
I	5A	6A	7A	8A	9A	10A	11A	12A	13A	14A	15A	16A	17A	18A
L	NOT USED	6B	7B	8B	9B	10B	11B	12B	13B	14B	15B	16B	17B	18B

EX. : 1A, 2A, ETC. = LOOP NO.'S

FS = FLASH SENSE
 ST = STOP TIME

INPUT FILE CONNECTION & PROGRAMMING CHART

LOOP NO.	LOOP TERMINAL	INPUT FILE POS.	PIN NO.	DETECTOR NO.	NEMA PHASE	CALL	EXTEND TIME	DELAY TIME	DETECTOR TYPE
1A	TB2-1,2	I1U	56	1	1	YES			S
2A	TB2-5,6	I2U	39	2	2	YES			N
2B	TB2-7,8	I2L	43	12	2	YES			N
4A	TB6-1,2	I7U	65	34	4	YES			S
4B	TB6-3,4	I7L	78	44	4	YES		3	S
4C	TB6-5,6	I8U	49	24	4	YES		15	S
5A	TB3-1,2	J1U	55	5	5	YES			S
6A	TB3-5,6	J2U	40	6	6	YES			N
6B	TB3-7,8	J2L	44	16	6	YES			N
*S6A	TB7-9,10	J9U	59	15	SYS	NO			N
*S6B	TB7-11,12	J9L	61	17	SYS	NO			N

* System detector only. Remove any assigned vehicle phase.

INPUT FILE POSITION LEGEND: J2L

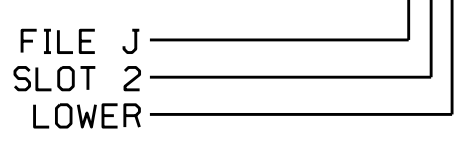

SPECIAL DETECTOR NOTE

For detection zones 3A, 3B & 3C install a microwave detection system for vehicle detection. Perform installation according to manufacturer's directions and NCDOT engineer-approved mounting locations to accomplish the detection scheme shown on the Signal Design Plan.

THIS ELECTRICAL DETAIL IS FOR THE SIGNAL DESIGN: 06-1346
 DESIGNED: July 2016
 SEALED: 10/12/2016
 REVISED: N/A

Electrical Detail

US 301/I-95 Bus. (Gillespie St.) at Ash Street/SR 2291 (Ivan Drive)

Division 6 Cumberland County Fayetteville

PLAN DATE: October 2016 REVIEWED BY: BAS

PREPARED BY: S. Armstrong REVIEWED BY:

REVISIONS INIT. DATE

750 N. Greenfield Pkwy, Garner, NC 27529

SEAL NORTH CAROLINA PROFESSIONAL ENGINEER KEITH M. MIMS

DocuSigned by: Keith M. Mims 10/17/2016 27807886C034AS DATE

SIG. INVENTORY NO. 06-1346

10-2016-2016 10:26 S:\11551\11551\Sigs\Sig. 250.1\Signal\work\hgr\061346_sm.elec.xxx.dgn sarms@ncdot.gov