

EDI MODEL 2018ECLip-NC CONFLICT MONITOR PROGRAMMING DETAIL

(remove jumpers and set switches as shown)

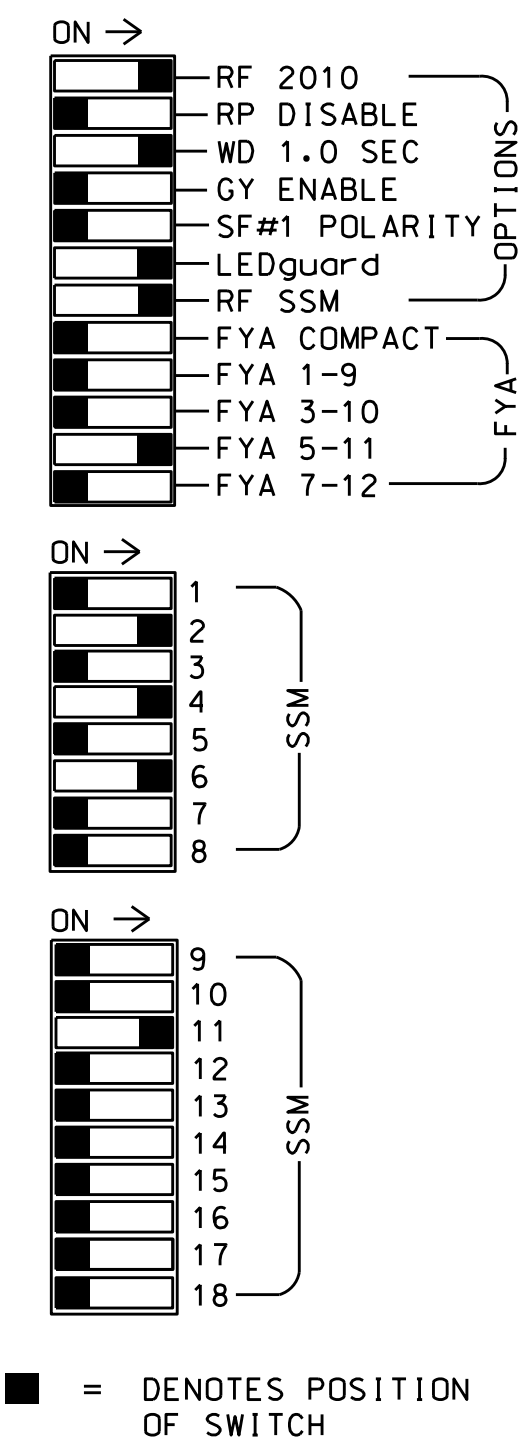
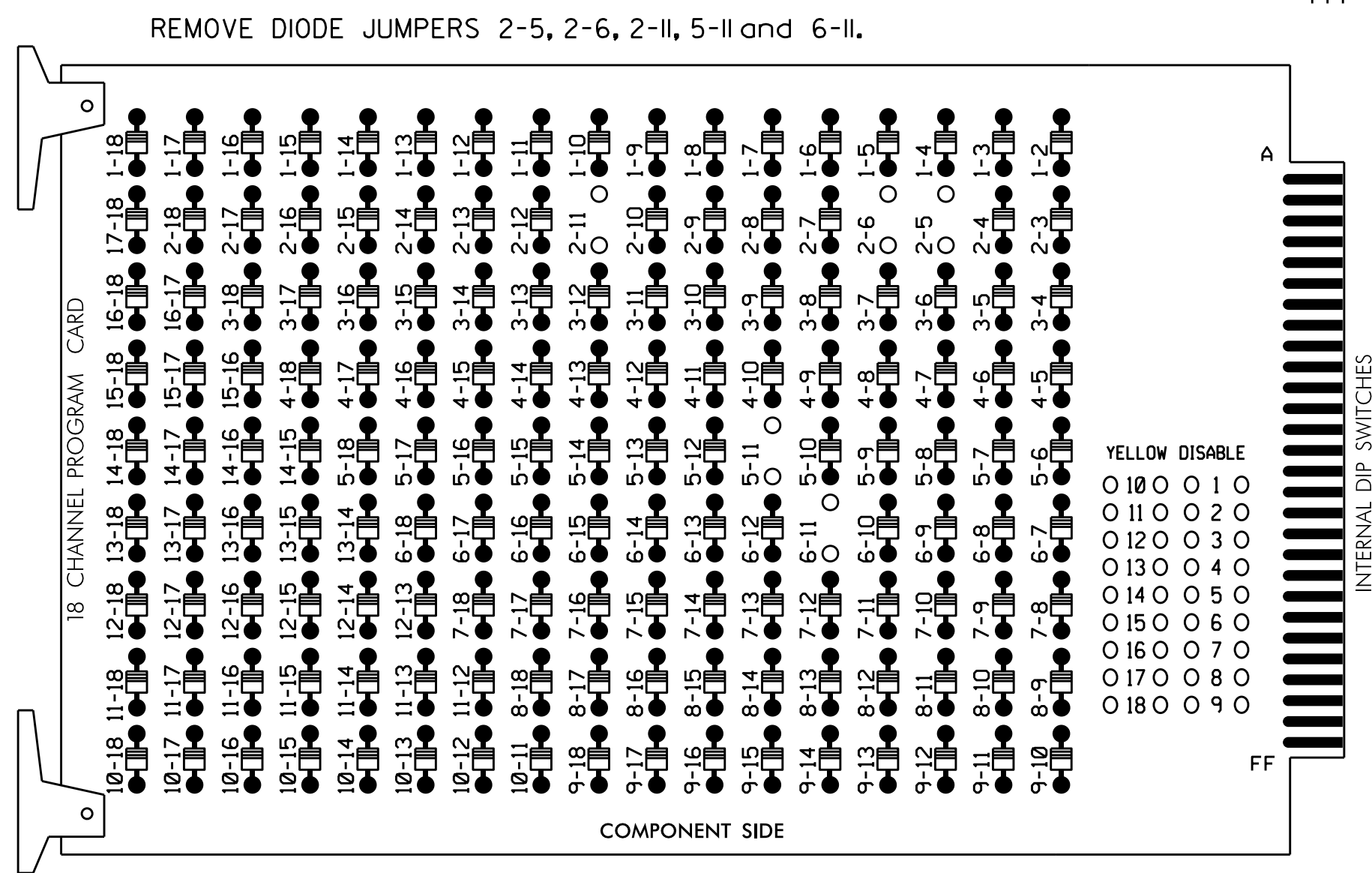

- NOTES:
- Card is provided with all diode jumpers in place. Removal of any jumper allows its channels to run concurrently.
 - Ensure jumpers SEL2-SEL5 and SEL9 are present on the monitor board.
 - Ensure that Red Enable is active at all times during normal operation.
 - Integrate monitor with Ethernet network in cabinet.

NOTES

- To prevent "flash-conflict" problems, insert red flash program blocks for all unused vehicle load switches in the output file. The installer shall verify that signal heads flash in accordance with the Signal Plans.
- Enable Simultaneous Gap-Out for all phases.
- Program phases 2 and 6 for volume density operation.
- Program controller to start up in phase 2 Green and 6 Green.
- The cabinet and controller are part of the Fayetteville Signal System.

EQUIPMENT INFORMATION

CONTROLLER.....2070E
 CABINET.....332 W/AUX
 SOFTWARE.....ECONOLITE ASC/3-2070
 CABINET MOUNT.....BASE
 OUTPUT FILE POSITIONS...18 WITH AUX. OUTPUT FILE
 LOAD SWITCHES USED.....S2,S5,S7,S8,AUX S4
 PHASES USED.....2,4,5,6
 OVERLAP "A".....NOT USED
 OVERLAP "B".....NOT USED
 OVERLAP "C".....*
 OVERLAP "D".....NOT USED
 * See overlap programming detail on sheet 2

SIGNAL HEAD HOOK-UP CHART

LOAD SWITCH NO.	S1	S2	S3	S4	S5	S6	S7	S8	S9	S10	S11	S12	AUX S1	AUX S2	AUX S3	AUX S4	AUX S5	AUX S6	
CMU CHANNEL NO.	1	2	13	3	4	14	5	6	15	7	8	16	9	10	17	11	12	18	
PHASE	1	2	2 PED	3	4	4 PED	5	6	6 PED	7	8	8 PED	OLA	OLB	SPARE	OLC	OLD	SPARE	
SIGNAL HEAD NO.	NU	21,22	NU	NU	41,42	NU	51*	61,62	NU	NU	NU	NU	NU	NU	NU	51*	NU	NU	
RED		128			101			134											
YELLOW		129			102		*	135											
GREEN		130			103			136											
RED ARROW																		A114	
YELLOW ARROW																			A115
FLASHING YELLOW ARROW																			A116
GREEN ARROW								133											

NU = Not Used
 * Denotes install load resistor. See load resistor installation detail this sheet.
 * See pictorial of head wiring in detail this sheet.

INPUT FILE POSITION LAYOUT

(front view)

FILE	1	2	3	4	5	6	7	8	9	10	11	12	13	14
U	S	∅ 2	S	S	S	S	S	S	S	S	S	S	S	FS
I	∅ 2	2A,2B	∅ 3	∅ 4	∅ 4	∅ 4	∅ 4	∅ 4	∅ 4	∅ 4	∅ 4	∅ 4	∅ 4	DC ISOLATOR
L	NOT USED	NOT USED	∅ 5	∅ 6	∅ 6	∅ 6	∅ 6	∅ 6	∅ 6	∅ 6	∅ 6	∅ 6	∅ 6	ST
U	∅ 5	∅ 6	S	S	S	S	S	S	S	S	S	S	S	DC ISOLATOR
J	5A	6A,6B	S	S	S	S	S	S	S	S	S	S	S	S
L	NOT USED	NOT USED	S	S	S	S	S	S	S	S	S	S	S	S

EX.: 1A, 2A, ETC. = LOOP NO.'S
 FS = FLASH SENSE
 ST = STOP TIME
 * Wired Input - Do not populate slot with detector card

INPUT FILE CONNECTION & PROGRAMMING CHART

LOOP NO.	LOOP TERMINAL	INPUT FILE POS.	PIN NO.	DETECTOR NO.	NEMA PHASE	CALL	EXTEND TIME	DELAY TIME	DETECTOR TYPE
2A,2B	TB2-5,6	I2U	39	2	2	YES			N
4A	TB4-9,10	I6U	41	4	4	YES			S
4B	TB4-11,12	I6L	45	14	4	YES		10	S
5A ¹	TB3-1,2	J1U	55	5	5	YES		20	S
		14U	47	22	2	YES		3	G
6A,6B	TB3-5,6	J2U	40	6	6	YES			N

¹Add jumper from J1-W to 14-W, on rear of input file.

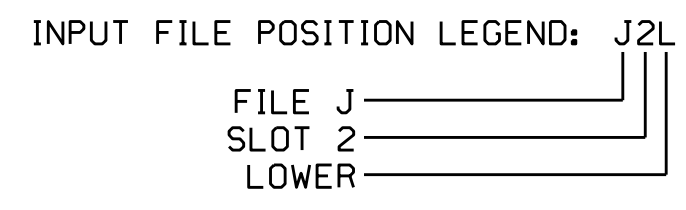

FYA SIGNAL WIRING DETAIL

(wire signal head as shown)

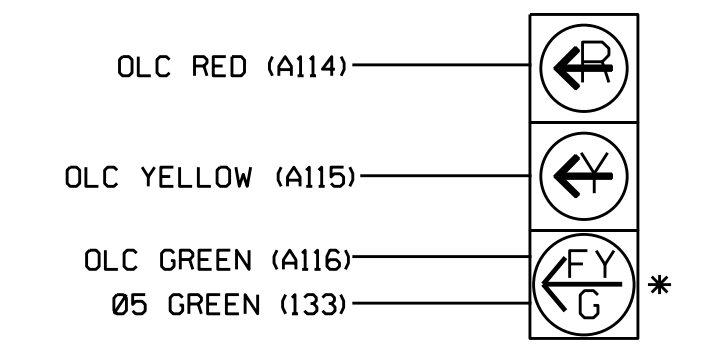

51
 * Bimodal Section

THIS ELECTRICAL DETAIL IS FOR THE SIGNAL DESIGN: 06-0544
 DESIGNED: July 2016
 SEALED: 8-23-16
 REVISED: N/A

LOAD RESISTOR INSTALLATION DETAIL

(install resistor as shown)

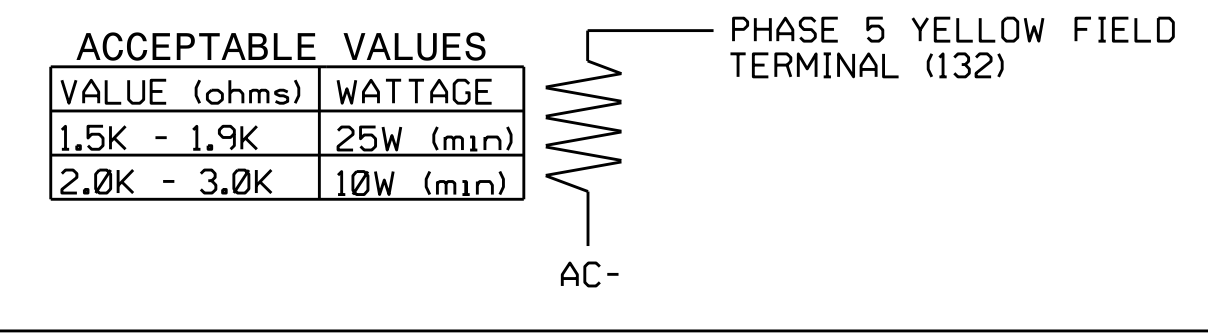

Electrical Detail Sheet 1 of 2

DOCUMENT NOT CONSIDERED FINAL UNLESS ALL SIGNATURES COMPLETED

Prepared in the Offices of:
 Transporatio Mobility and Safety Solutions
 750 N. Greenfield Pkwy, Garner, NC 27529

US 401 Bus./SR 3828 (Robeson St) at NC 87 (MLK Jr. Fwy) Off Ramp/On Loop
 Division 6 Cumberland County Fayetteville
 PLAN DATE: August 2016 REVIEWED BY: BAS
 PREPARED BY: James Peterson REVIEWED BY:

REVISIONS: INIT. DATE

Seal of Keith M. Mims, Professional Engineer, No. 036880, State of North Carolina.

DocuSigned by: Keith M. Mims 8/31/2016
 2F8078EBCD3445 DATE

SIG. INVENTORY NO. 06-0544

31-100-2016_1B-14
 S:\1\TSS\1\TSS\Sigma\work\gpc\060544_sml.ele...xxx.dgn
 J. Peterson