

**PHASING DIAGRAM**

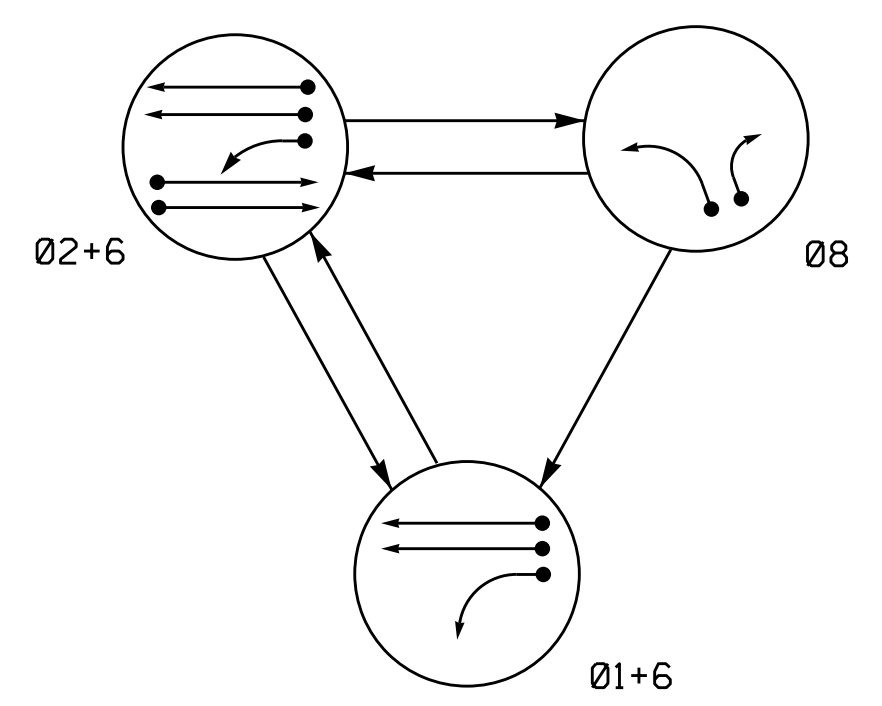

**PHASING DIAGRAM DETECTION LEGEND**  
 ● DETECTED MOVEMENT  
 ○ UNDETECTED MOVEMENT (OVERLAP)  
 - - - UNSIGNALIZED MOVEMENT  
 - - - PEDESTRIAN MOVEMENT

**TABLE OF OPERATION**

SIGNAL FACE	PHASE			
	01+6	02+6	08	FULL
11	←	←	←	←
21,22	R	G	R	Y
61,62	G	G	R	Y
81,82	R	R	G	R

**SIGNAL FACE I.D.**

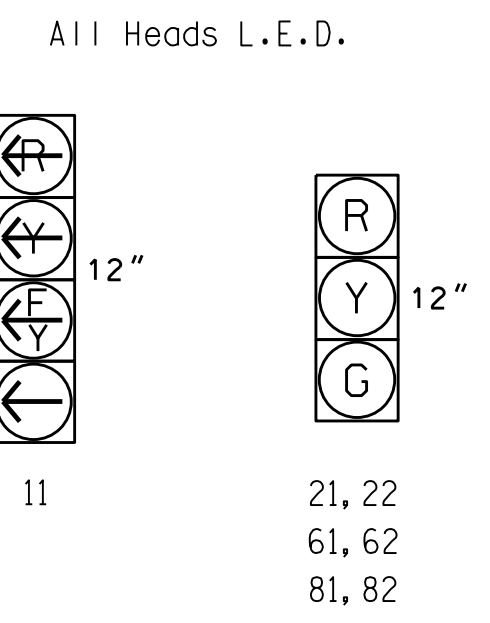

**ASC/3 DETECTOR INSTALLATION CHART**

LOOP	SIZE (FT)	DISTANCE FROM STOPBAR (FT)	TURNS	NEW LOOP	PROGRAMMING					TYPE	LOOP SYSTEM	NEW CARD
					PHASE	CALLING	EXTEND TIME	DELAY TIME				
1A	6X60	0	2-4-2	-	1	Yes	-	15	S	-	X	
2A	6X6	300	2	-	2	Yes	-	-	N	-	X	
2B	6X6	300	2	-	2	Yes	-	-	N	-	X	
6A	6X6	300	4	-	6	Yes	-	-	N	-	X	
6B	6X6	300	4	-	6	Yes	-	-	N	-	X	
8A	6X70	+5	1	-	8	Yes	-	-	S	-	X	
8B	6X25	+5	2	-	8	Yes	-	-	S	-	X	

**3 Phase Fully Actuated Fayetteville City System**

**NOTES**

- Refer to "Roadway Standard Drawings NCDOT" dated January 2012 and "Standard Specifications for Roads and Structures" dated January 2012.
- Do not program signal for late night flashing operation unless otherwise directed by the Engineer.
- Phase 1 may be lagged.
- Set all detector units to presence mode.
- In the event of loop replacement, refer to the current ITS and Signals Design Manual and submit a Plan of Record to the Signal Design Section.
- Locate new cabinet so as not to obstruct sight distance of vehicles turning right on red.
- Pavement markings are existing.
- Maximum times shown in timing chart are for free-run operation only. Coordinated signal system timing values supersede these values.

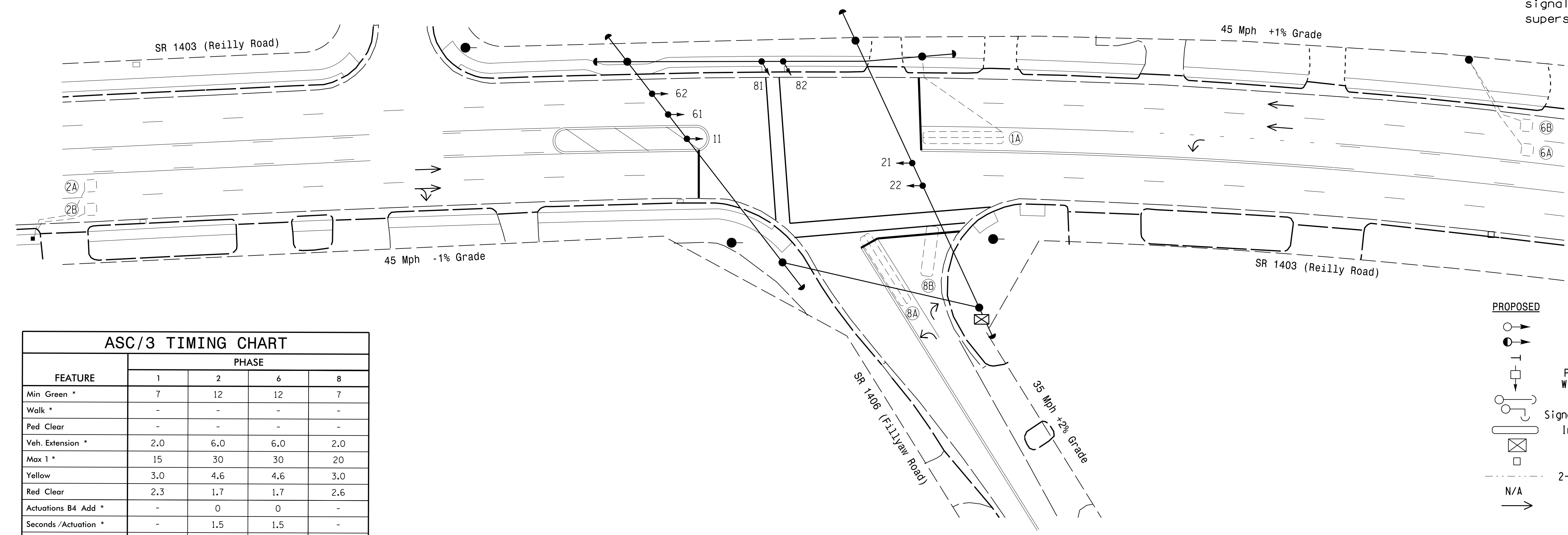

**ASC/3 TIMING CHART**

FEATURE	PHASE			
	1	2	6	8
Min Green *	7	12	12	7
Walk *	-	-	-	-
Ped Clear	-	-	-	-
Veh. Extension *	2.0	6.0	6.0	2.0
Max 1 *	15	30	30	20
Yellow	3.0	4.6	4.6	3.0
Red Clear	2.3	1.7	1.7	2.6
Actuations B4 Add *	-	0	0	-
Seconds / Actuation *	-	1.5	1.5	-
Max Initial *	-	34	34	-
Time Before Reduction *	-	15	15	-
Time To Reduce *	-	30	30	-
Minimum Gap	-	3.0	3.0	-
Locking Detector	-	X	X	-
Recall Position	-	VEH. RECALL	VEH. RECALL	-
Dual Entry	-	-	-	-
Simultaneous Gap	X	X	X	X

\* These values may be field adjusted. Do not adjust Min Green and Extension times for phases 2 and 6 lower than what is shown. Min Green for all other phases should not be lower than 4 seconds.

**LEGEND**

PROPOSED	EXISTING
○ Traffic Signal Head	● Traffic Signal Head
○ Modified Signal Head	N/A
○ Sign	N/A
○ Pedestrian Signal Head With Push Button & Sign	○ Pedestrian Signal Head With Push Button & Sign
○ Signal Pole with Guy	○ Signal Pole with Guy
○ Signal Pole with Sidewalk Guy	○ Signal Pole with Sidewalk Guy
○ Inductive Loop Detector	○ Inductive Loop Detector
○ Controller & Cabinet	○ Controller & Cabinet
○ Junction Box	○ Junction Box
○ 2-in Underground Conduit	○ 2-in Underground Conduit
○ Right of Way	○ Right of Way
○ Directional Arrow	○ Directional Arrow

**Signal Upgrade - Final**

Prepared In the Offices of:  
  
**SR 1403 (Reilly Rd) at SR 1406 (Fillyaw Rd)**  
 Division 6 Cumberland County Fayetteville  
 PLAN DATE: February 2016 REVIEWED BY: JPG  
 PREPARED BY: JPG/KGP REVIEWED BY:  
 SCALE: 1"=30'  
 REVISIONS: INIT. DATE  
 DocuSigned by: Jason P. Gallaway 5/6/2016  
 SIG. INVENTORY NO. 06-0543

**DOCUMENT NOT CONSIDERED FINAL UNLESS ALL SIGNATURES COMPLETED**

19-0075-2016\_08-59  
 S:\115451\115451\SIGNAL DESIGN\Section\Eastern Region\014-064U-5742 Fayetteville ASC\3\06-0543\060543F\_sig\_dsn\_20131106.dgn  
 J:\0110602