

EDI MODEL 2018EClip-NC CONFLICT MONITOR PROGRAMMING DETAIL

(remove jumpers and set switches as shown)

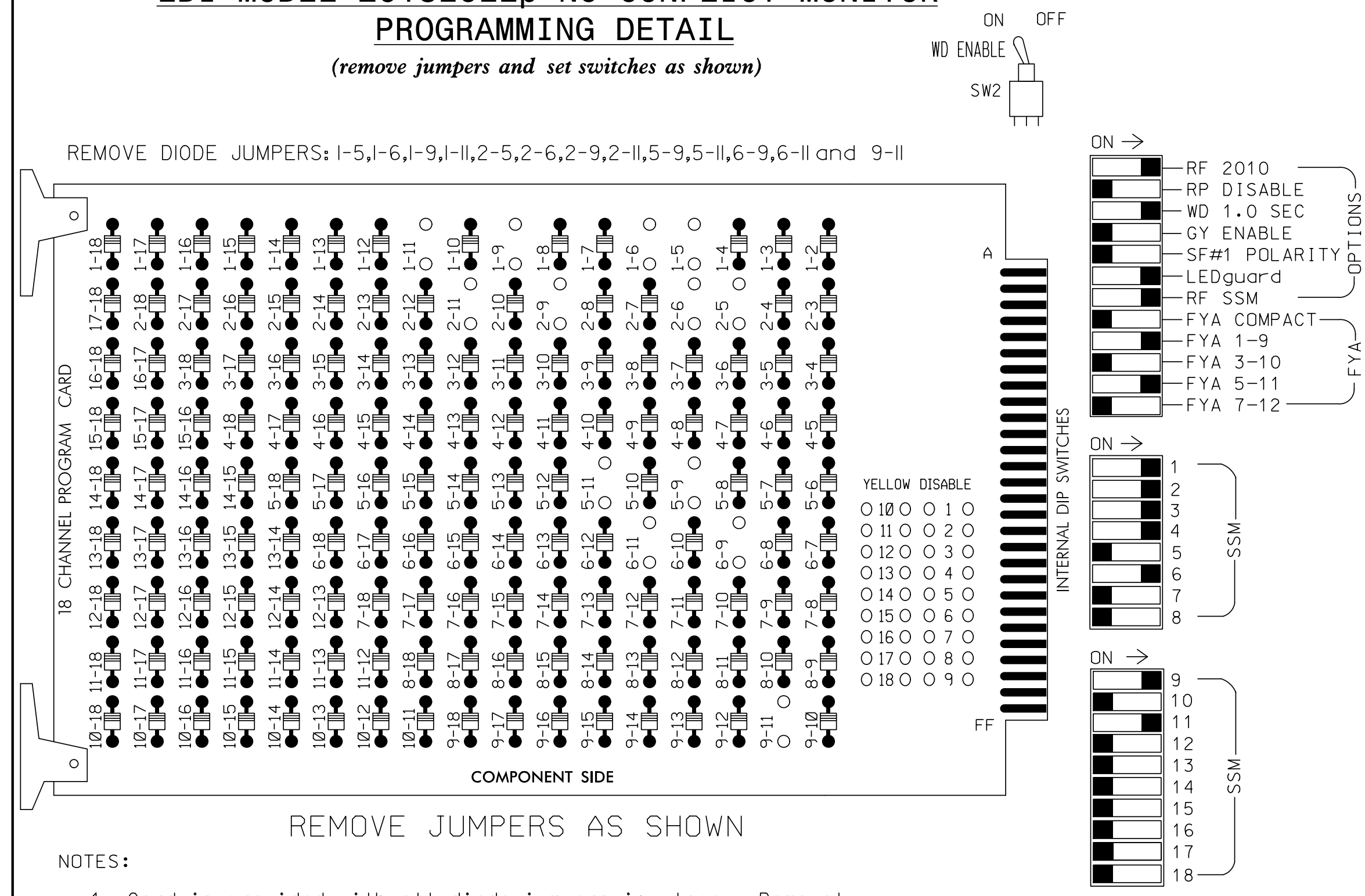

- REMOVE JUMPERS AS SHOWN
- NOTES:
- Card is provided with all diode jumpers in place. Removal of any jumper allows its channels to run concurrently.
 - Ensure jumpers SEL2-SEL5 and SEL9 are present on the monitor board.
 - Ensure that Red Enable is active at all times during normal operation.
 - Integrate monitor with Ethernet network in cabinet.

NOTES

- To prevent "flash-conflict" problems, insert red flash program blocks for all unused vehicle load switches in the output file. The installer shall verify that signal heads flash in accordance with the Signal Plans.
- Enable Simultaneous Gap-Out for all phases.
- Program phases 2 and 6 for volume density operation.
- Program controller to start up in phase 2 Green and 6 Green.
- The cabinet and controller are part of the Fayetteville Signal System.

EQUIPMENT INFORMATION

CONTROLLER.....2070E
 CABINET.....332 W/AUX
 SOFTWARE.....ECONOLITE ASC/3-2070
 CABINET MOUNT.....BASE
 OUTPUT FILE POSITIONS...18 WITH AUX. OUTPUT FILE
 LOAD SWITCHES USED.....S1,S2,S4,S5,S7,S8,
 AUX S1,AUX S4
 PHASES USED.....1,2,3,4,5,6
 OVERLAP "A".....*
 OVERLAP "B".....NOT USED
 OVERLAP "C".....*
 OVERLAP "D".....NOT USED
 * See overlap programming detail on sheet 2

SIGNAL HEAD HOOK-UP CHART

LOAD SWITCH NO.	S1	S2	S3	S4	S5	S6	S7	S8	S9	S10	S11	S12	AUX S1	AUX S2	AUX S3	AUX S4	AUX S5	AUX S6	
CMU CHANNEL NO.	1	2	13	3	4	14	5	6	15	7	8	16	9	10	17	11	12	18	
PHASE	1	2	2 PED	3	4	4 PED	5	6	6 PED	7	8	8 PED	OLA	OLB	SPARE	OLC	OLD	SPARE	
SIGNAL HEAD NO.	11*	32	21,22	NU	31	32	41,42	43,44	62	NU	51*	61,62	NU	NU	NU	11*	NU	51*	NU
RED	*	128		116	116		101					134							
YELLOW			129	117	117		102		*	135									
GREEN			130	118	118		103			136									
RED ARROW							101									A121		A114	
YELLOW ARROW		126					102	102								A122		A115	
FLASHING YELLOW ARROW																A123		A116	
GREEN ARROW	127	127		118	103	103	133												

NU = Not Used
 * Denotes install load resistor. See load resistor installation detail this sheet.
 * See pictorial of head wiring in detail this sheet.

INPUT FILE POSITION LAYOUT

(front view)

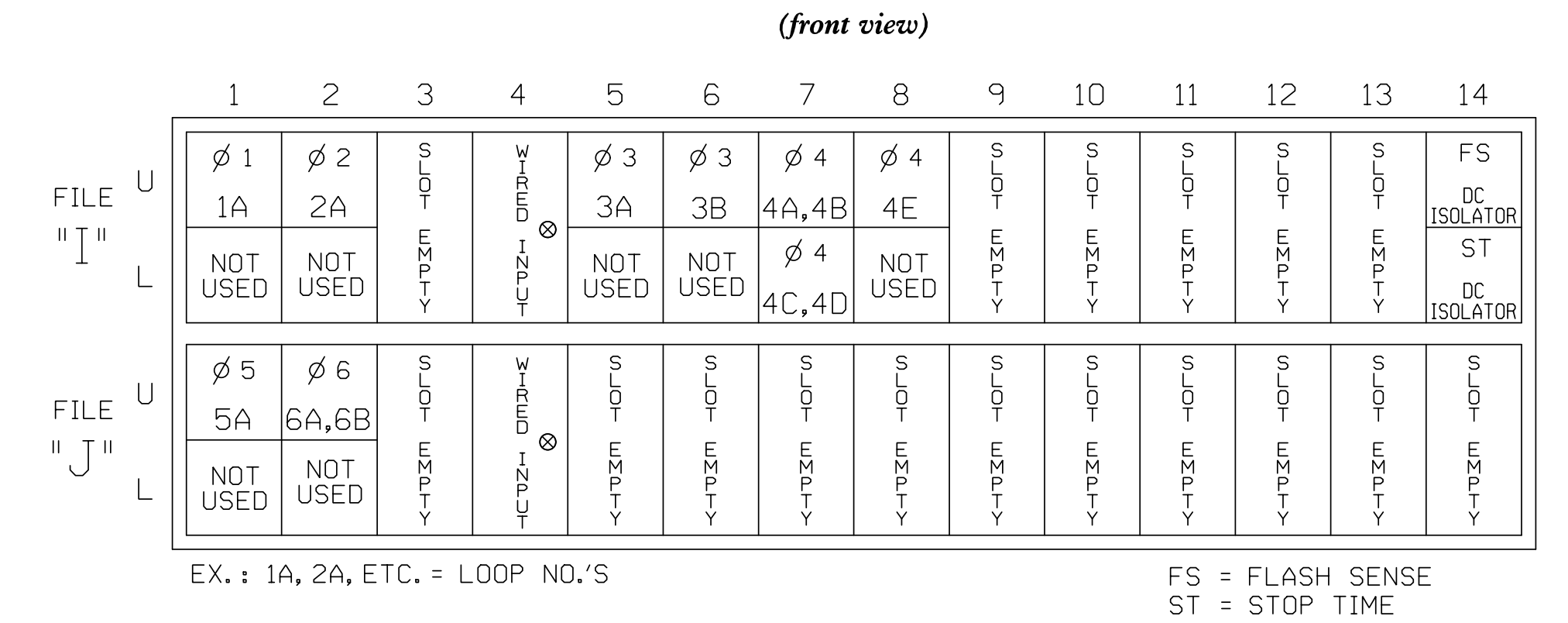

EX.: 1A, 2A, ETC. = LOOP NO.'S
 FS = FLASH SENSE
 ST = STOP TIME
 ⊗ Wired Input - Do not populate slot with detector card

INPUT FILE CONNECTION & PROGRAMMING CHART

LOOP NO.	LOOP TERMINAL	INPUT FILE POS.	PIN NO.	DETECTOR NO.	NEMA PHASE	CALL	EXTEND TIME	DELAY TIME	DETECTOR TYPE
1A ¹	TB2-1,2	I1U	56	1	1	YES		15	S
	-	J4U	48	26	6	YES		3	G
2A	TB2-5,6	I2U	39	2	2	YES			N
3A	TB4-5,6	I5U	58	3	3	YES		3	S
3B	TB4-9,10	I6U	41	4	3	YES		15	S
4A,4B	TB6-1,2	I7U	65	34	4	NO	5.0		N
4C,4D	TB6-3,4	I7L	78	44	4	YES			S
4E	TB6-5,6	I8U	49	24	4	YES		10	S
5A ²	TB3-1,2	J1U	55	5	5	YES		15	S
	-	I4U	47	22	2	YES		3	G
6A,6B	TB3-5,6	J2U	40	6	6	YES			N

- Add jumper from I1-W to J4-W, on rear of input file.
- Add jumper from J1-W to I4-W, on rear of input file.

FYA SIGNAL WIRING DETAIL

(wire signal heads as shown)

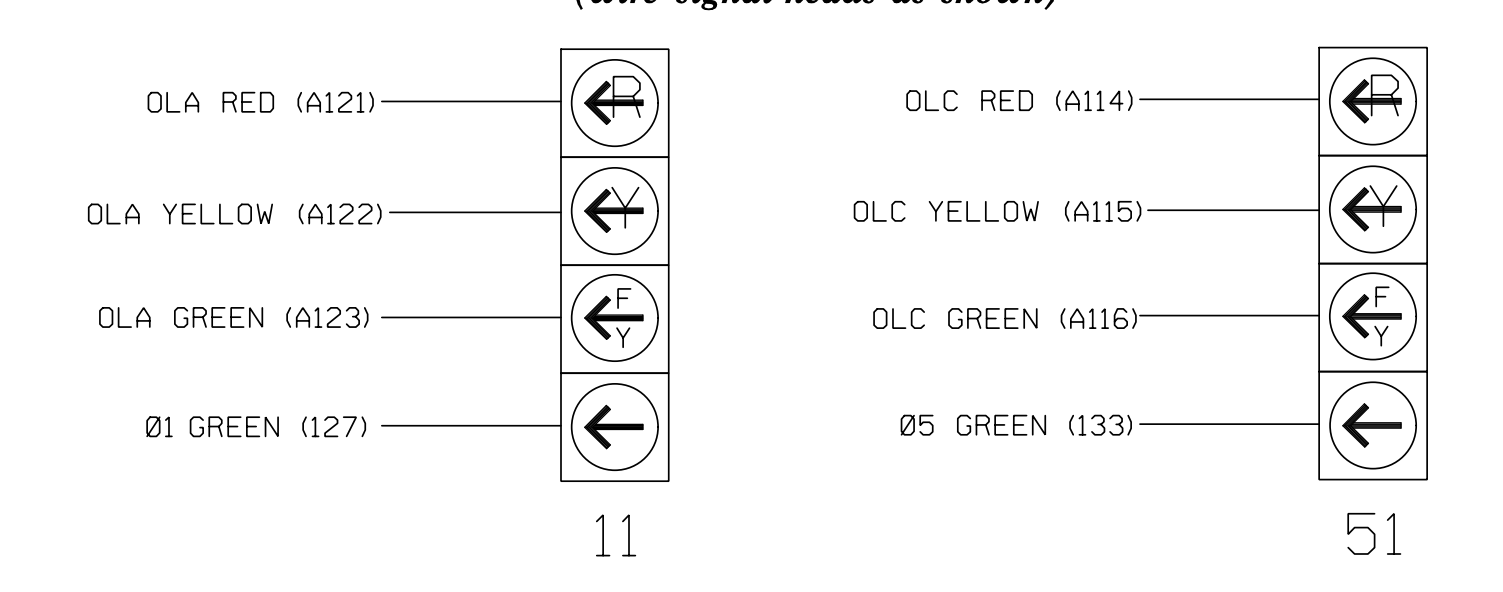

LOAD RESISTOR INSTALLATION DETAIL

(install resistors as shown)

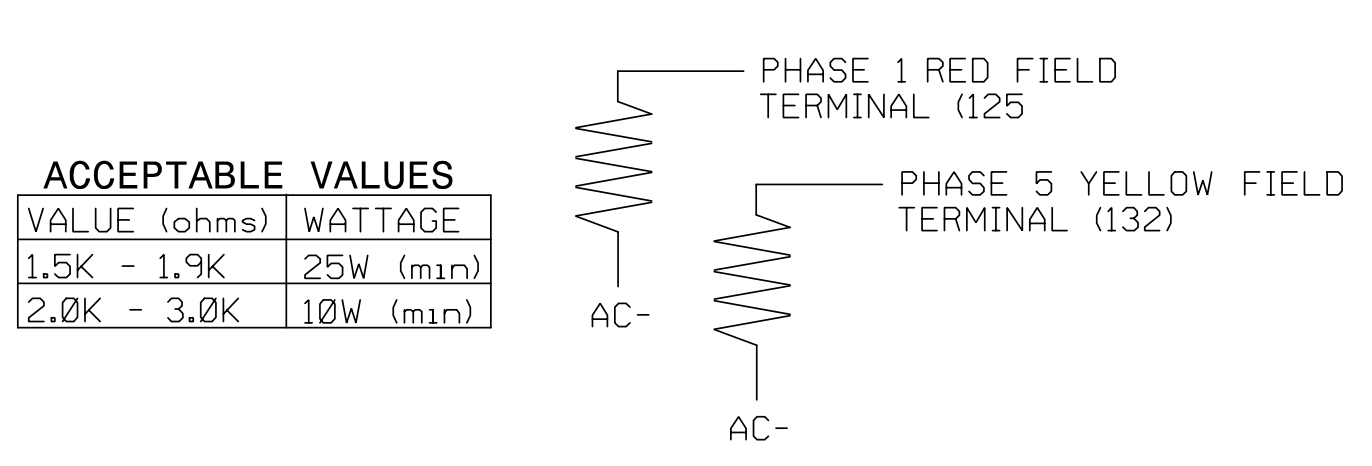

VALUE (ohms)	WATTAGE
1.5K - 1.9K	25W (min)
2.0K - 3.0K	10W (min)

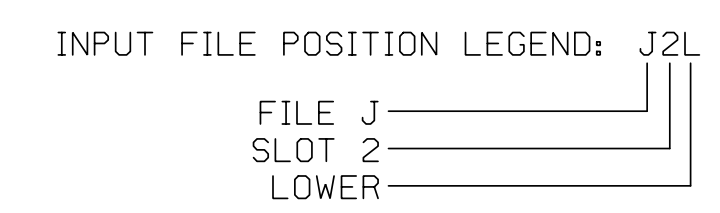

THIS ELECTRICAL DETAIL IS FOR THE SIGNAL DESIGN: 06-0788
 DESIGNED: April 2016
 SEALED: 7/7/2016
 REVISED:

Electrical Detail Sheet 1 of 2

DOCUMENT NOT CONSIDERED FINAL UNLESS ALL SIGNATURES COMPLETED

Electrical and Programming Details For:

SR 1600 (McArthur Road) at SR 1611 (Andrews Road / Braxton Boulevard)
 Division 6 Cumberland County Fayetteville
 PLAN DATE: July 2016 REVIEWED BY: SL Phillips
 PREPARED BY: SP Pennington REVIEWED BY: KB Baumann
 REVISIONS: INIT. DATE

SEAL

 9/16/2016
 DATE
 SIG. INVENTORY NO. 06-0788

PLANS PREPARED IN THE OFFICE OF:
KimleyHorn
 NC License #F-0102
 421 Fayetteville Street, Suite 600
 Raleigh, NC 27601
 (919) 617-2000

9/16/2016 K:\MAIL_TPI\OK_SIGNALS\4011036345_Fayetteville_Electr\Coils\654 - Signal Design\4th_Submit\Final\41771_060788-2016e1.dgn Susan Pennington