

### ECONOLITE ASC/3-2070 EV PREEMPT PROGRAMMING DETAIL

(program controller as shown)

- From Main Menu select **4. PREEMPTOR/TSP**
- From PREEMPTOR/TSP/SCP Submenu select **1. PREEMPT PLAN 1-10**

Place cursor in [ ] next to Preempt Plan and press 2. Then press the right cursor arrow and toggle the controller to YES. Next cursor down. This will select Preempt #2.

PREEMPT PLAN [ 2 ]	ENABLE....YES
VEH/PED 1 2 3 4 5 6 7 8 9 0 1 2 3 4 5 6	
OVERLAP A B C D E F G H I J K L M N O P	
TRKCLR V . . . . .	
TRKCLR O . . . . .	
ENA TRL . . . . .	
DWEL VEH . . X . . . . .	
DWEL PED . . . . .	
DWEL OLP . . . . .	
CYC VEH . . . . .	
CYC PED . . . . .	
CYC OLP . . . . .	
EXIT PH . X . . . X . . . . .	
EXIT CAL . . . . .	
SP FUNC . . . . .	

ENABLE... YES	IPMT	OVRIDE..	IINTERLOCK.	NO
DET LOCK... X	IDELAY..	O	IINHIBIT...	0
OVERIDE FL. .	IDURATION	O	ICLR-GRN...	NO
TERM OLP. NO	IPC>YEL	NO	ITERM PH	NO
PED DARK.. NO	ITC RESRV	YES	IDWELL FL	OFF
LINK PMT....O	IX FLCOLR	RED	IXIT OPT.	OFF
X TMG PLN...O	IRE-SERV..	O	IFLT TYPE.	HARD
FREE DUR	PMTIR1	NO	IR2	NO
NO	IR3	NO	IR4	NO
--TIMING----	WALK	IPED	CLIMN	GRI
YEL	I	RED		
ENTRANCE	TM.	255	I	255
1	255	1	125	5
125	5			
-----MIN	GRIEXT	GRIMX	GRI	YEL
I	RED			
TRACK CLEAR	O	I	O	I
25	5	125	5	125
5				
-----MIN	DLIP	TEXT	IMX	TMI
YEL	I	RED		
DWL/CYC-EXIT	O	I	O	I
25	5	125	5	125
5				
PMT ACTIVE	OUT..ON	PMT	ACT	DWELL...
NO				
OTHER - PRI	PMT.OFF	NON-PRI	PMT....	OFF
INH EXT	TIME... 0.0	PED	PR	RETURN...OFF
PRIORITY	RETURN.OFF	QUEUE	DELAY....	OFF
COND	DELAY.....	OFF		
PHASES	1	2	3	4
5	6	7	8	
PR RTN%	0	0	0	0
0	0	0	0	0
PHASES	9	10	11	12
13	14	15	16	
PR RTN%	0	0	0	0
0	0	0	0	0

### EV Preemption 2 Control Box Wiring Detail

(wire as shown below)

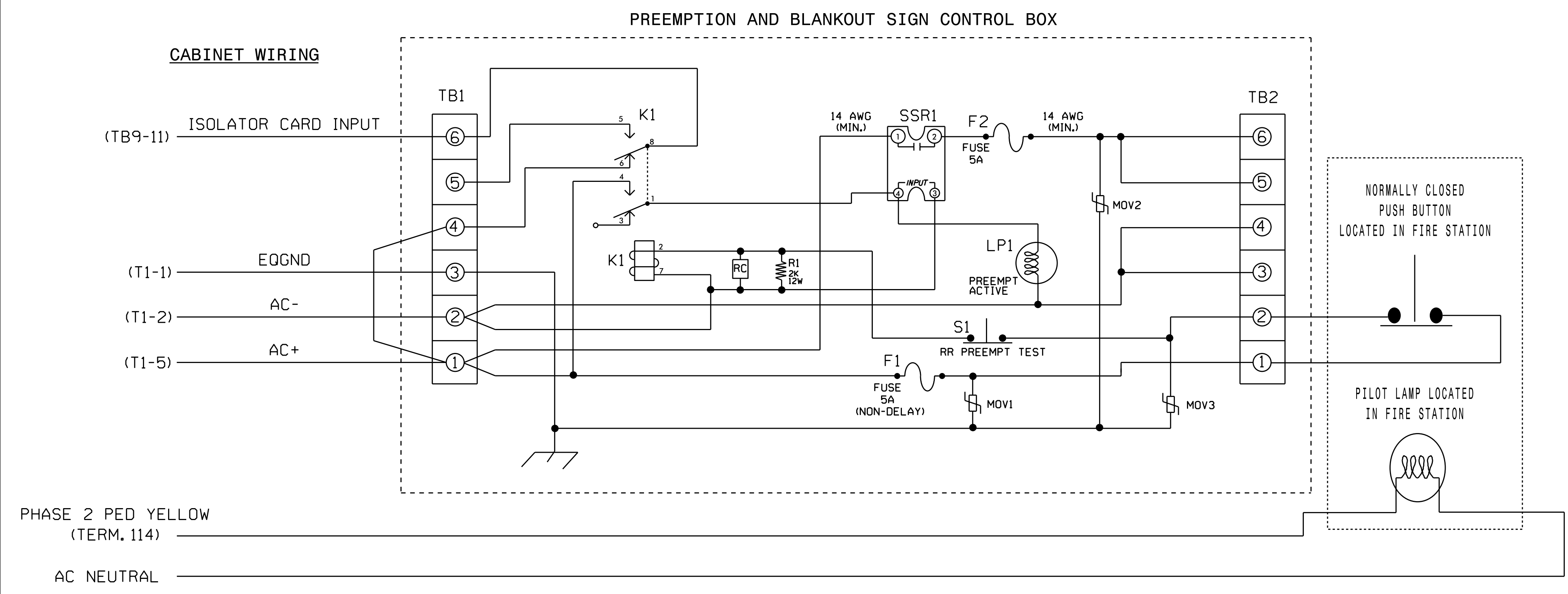

### NOTES

- Relay K1 is shown in the energized (Preempt not active) normal operation state.
- Relay 'K1' is an enclosed DPDT general purpose relay with a 120VAC coil, 10A contacts, and octal-style plug.
- Relay SSR1 is a SPST (normally open) Solid State Relay with AC input and AC (25 amp) output.
- AC Isolator Card shall activate preemption upon removal of AC+ from the input (as shown above). To accomplish this, set invert dip switch on AC Isolator Card.

### FRONT VIEW

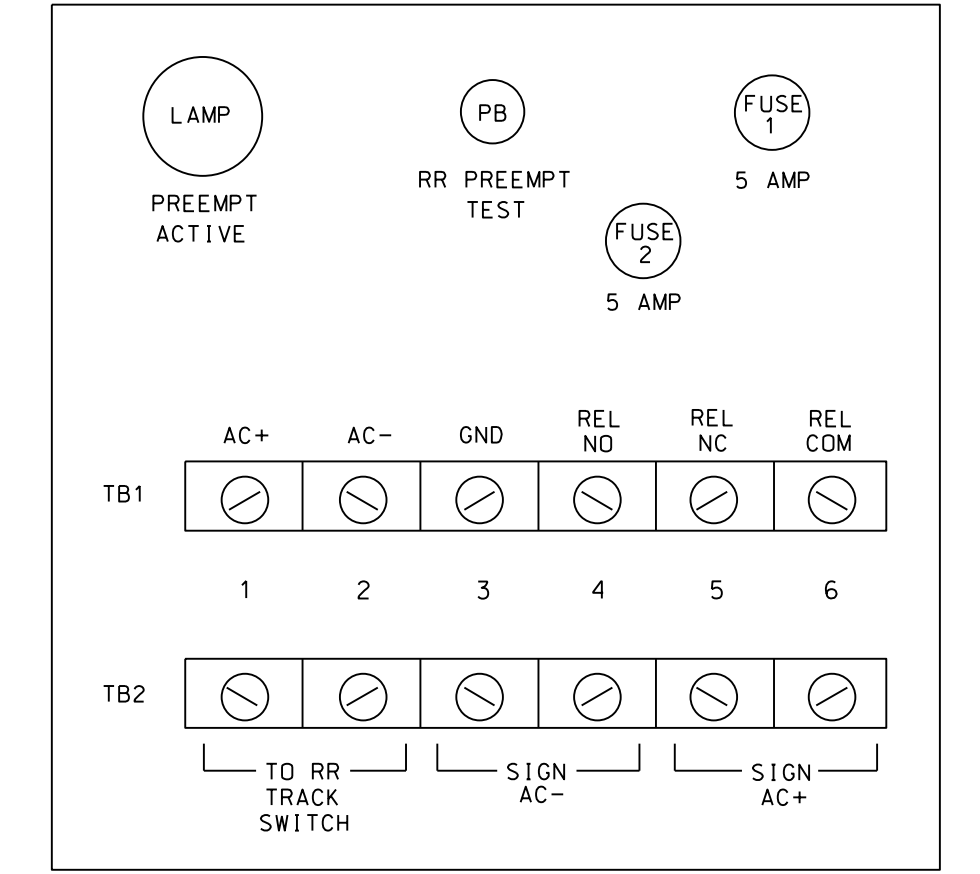

THIS ELECTRICAL DETAIL IS FOR THE SIGNAL DESIGN: 06-0383  
 DESIGNED: June 2016  
 SEALED: 9-28-16  
 REVISED: N/A

24-0073-2016 10-11  
 S:\IT\5351\15\Sig\el\work\hgr\oups\sig\_Mon\Peter.som\060383\_smc.ele\_20161019.dgn  
 J.Peter

Electrical Detail - Sheet 4 of 4

DOCUMENT NOT CONSIDERED FINAL UNLESS ALL SIGNATURES COMPLETED

ELECTRICAL AND PROGRAMMING DETAILS FOR: Prepared in the Offices of:  Signal Management Systems, Inc. 750 N. Greenfield Pkwy, Garner, NC 27529	SR 1141 (Cumberland Road) at SR 2920 (Upchurch Drive)/ SR 1149 (Boone Trail) Division 6 Cumberland County Fayetteville PLAN DATE: August 2016 REVIEWED BY: BAS PREPARED BY: James Peterson REVIEWED BY:	SEAL  Keith M. Mims 10/21/2016 DATE SIG. INVENTORY NO. 06-0383
---	--	---