

ECONOLITE ASC/3-2070 EV PREEMPT PROGRAMMING DETAIL

(program controller as shown)

- From Main Menu select **4. PREEMPTOR/TSP**
- From PREEMPTOR/TSP/SCP Submenu select **1. PREEMPT PLAN 1-10**

Place cursor in [] next to Preempt Plan and press 1. Then press the right cursor arrow and toggle the controller to YES. Next cursor down. This will select Preempt #1.

PREEMPT PLAN [1]	ENABLE....YES
VEH/PED 1 2 3 4 5 6 7 8 9 0 1 2 3 4 5 6	
OVERLAP A B C D E F G H I J K L M N O P	
TRKCLR V	
TRKCLR O	
ENA TRL	
DWEL VEH	
DWEL PED	
DWEL OLP	
CYC VEH	
CYC PED	
CYC OLP	
EXIT PH . X . . . X	
EXIT CAL	
SP FUNC	

ENABLE... YES	PMT OVRIDE..	INTERLOCK..	NO
DET LOCK... X	IDELAY..	OINHIBIT... 0	
OVERIDE FL. .	IDURATION	OICLR-GRN... NO	
TERM OLP. NO	IPC>YEL	NOITERM PH	NO
PED DARK.. NO	ITC RESRV	YESIDWELL FL	OFF
LINK PMT...O	IX FLCOLR	REDIEXIT OPT.	OFF
X TMG PLN...O	IRE-SERV..	OIFLT TYPE.HARD	
FREE DUR PMT	IR1 NOIR2	NOIR3 NOIR4	NO
--TIMING----	WALKIPED	CLIMN GRI YELI	RED
ENTRANCE TM.	2551 2551	1125.5125.5	
-----MIN	GRIEXT GRIMX	GRI YELI	RED
TRACK CLEAR	01 01	0125.5125.5	
-----MIN	DLIPMTEXTIMX	TMI YELI	RED
DWL/CYC-EXIT	01 0.01	0125.5125.5	
PMT ACTIVE OUT..ON	PMT ACT	DWELL...NO	
OTHER - PRI	PMT.OFF	NON-PRI	PMT....OFF
INH EXT TIME... 0.0	PED PR	RETURN...OFF	
PRIORITY RETURN.OFF	QUEUE	DELAY.... OFF	
COND DELAY.....OFF			
PHASES	1 2 3 4 5 6 7 8		
PR RTN%	0 0 0 0 0 0 0 0		
PHASES	9 10 11 12 13 14 15 16		
PR RTN%	0 0 0 0 0 0 0 0		

EV Preemption 1 Control Box Wiring Detail

(wire as shown below)

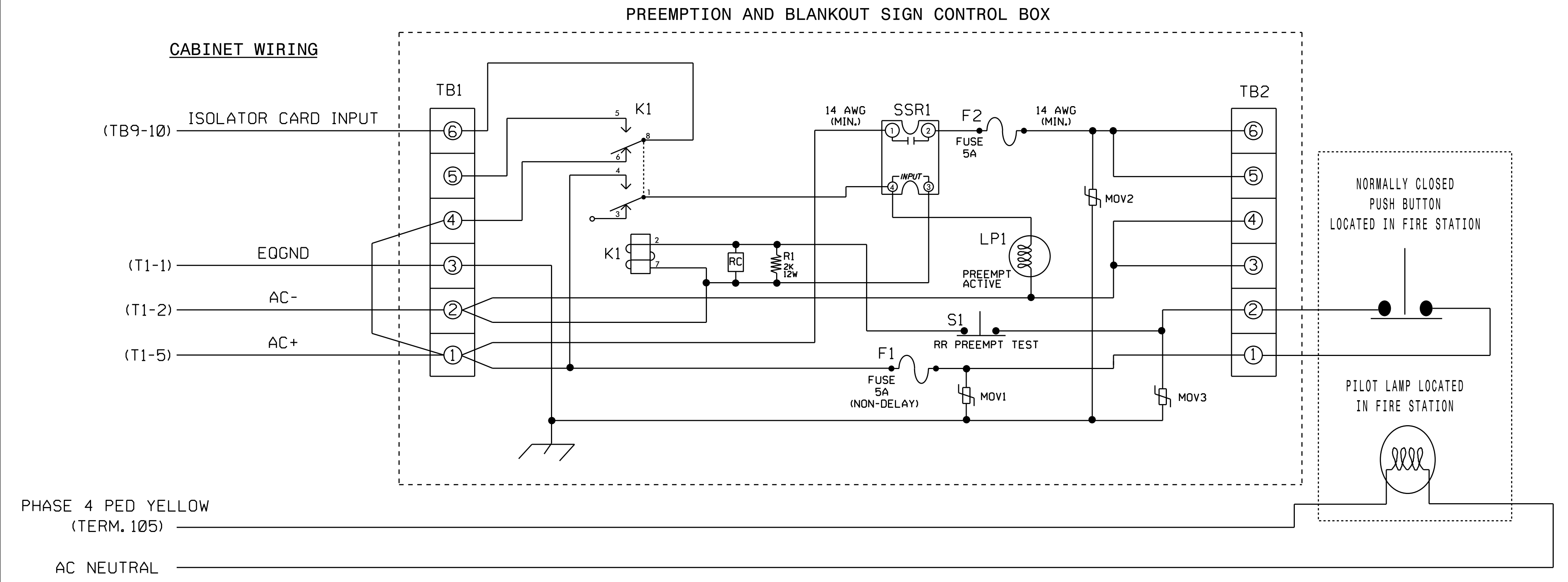

PHASE 4 PED YELLOW (TERM. 105) _____
AC NEUTRAL _____

NOTES

- Relay K1 is shown in the energized (Preempt not active) normal operation state.
- Relay 'K1' is an enclosed DPDT general purpose relay with a 120VAC coil, 10A contacts, and octal-style plug.
- Relay SSR1 is a SPST (normally open) Solid State Relay with AC input and AC (25 amp) output.
- AC Isolator Card shall activate preemption upon removal of AC+ from the input (as shown above). To accomplish this, set invert dip switch on AC Isolator Card.
- IMPORTANT!!** A jumper must be added between input file terminals J14-E and J14-K if not already present. Also, terminal TB9-12 (on input panel) shall be connected to AC neutral (jumper may have to be added).

THIS ELECTRICAL DETAIL IS FOR THE SIGNAL DESIGN: 06-0383
DESIGNED: June 2016
SEALED: 9-28-16
REVISED: N/A

AC ISOLATOR (MODEL 252) OUTPUT PROGRAMMING DETAIL

(set DIP switches as shown below)

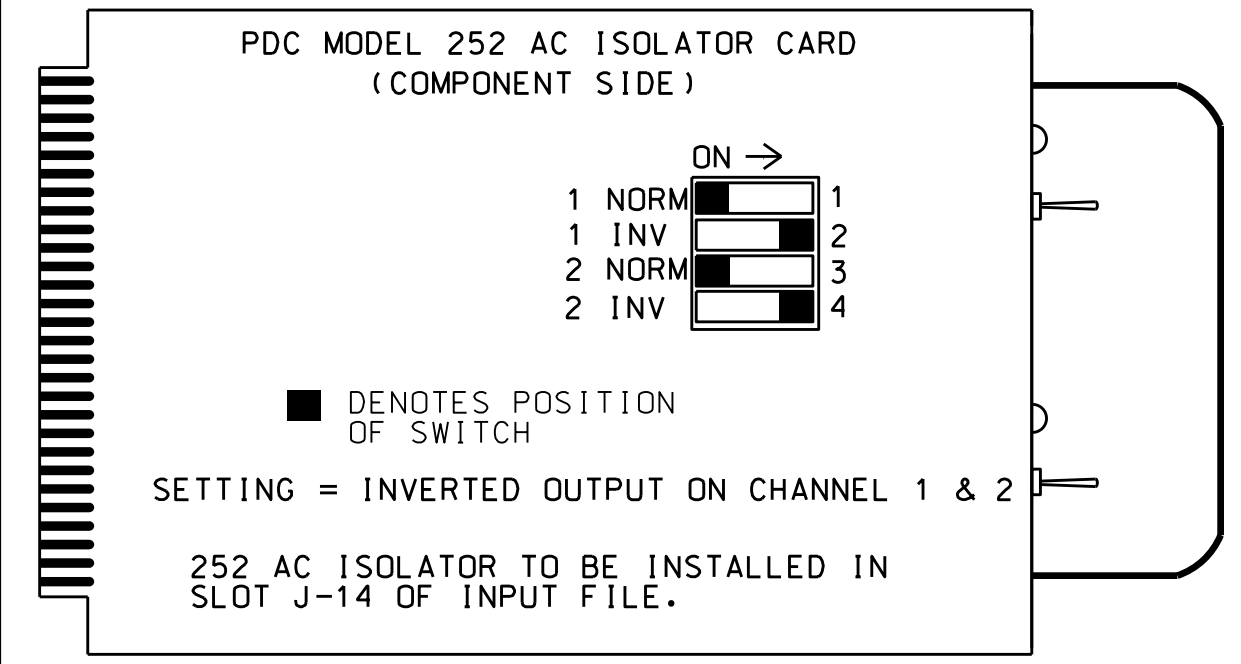

NOTE: IF ANOTHER MANUFACTURER TYPE OF AC ISOLATOR IS USED, OUTPUT PROGRAMMING IS LIKELY NOT TO EQUATE TO THAT SHOWN ABOVE.

FRONT VIEW

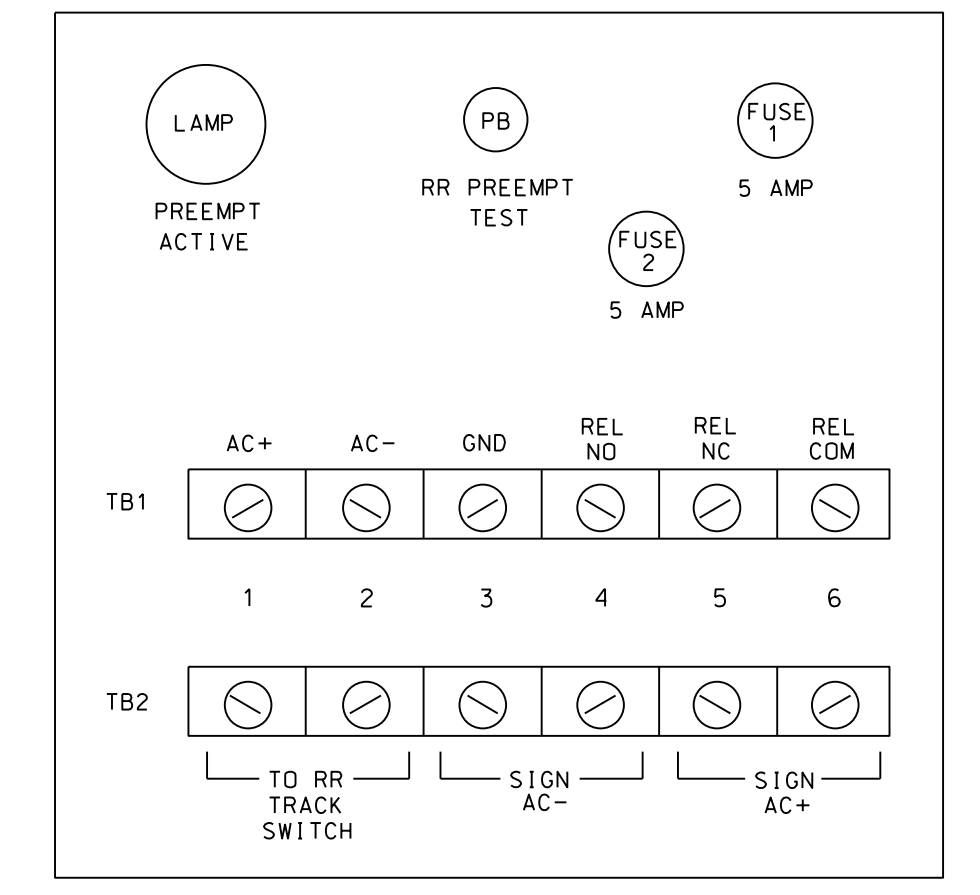

Electrical Detail - Sheet 3 of 4

DOCUMENT NOT CONSIDERED FINAL UNLESS ALL SIGNATURES COMPLETED

	<p>SR 1141 (Cumberland Road) at SR 2920 (Upchurch Drive)/ SR 1149 (Boone Trail)</p> <p>Division 6 Cumberland County Fayetteville</p> <p>PLAN DATE: August 2016 REVIEWED BY: BAS</p> <p>PREPARED BY: James Peterson REVIEWED BY:</p>
<p>750 N. Greenfield Pkwy, Garner, NC 27529</p>	<p>REVISIONS</p> <p>INIT. DATE</p> <p>DocuSigned by: Keith M. Mims 10/21/2016 27807886C034AS DATE</p> <p>SIG. INVENTORY NO. 06-0383</p>

24-007-2016 11:16
 S:\IT\5510\15 Signal\work\hgr\oups\51g_Mim#Peterson\060383_snc.ele_20161019.dgn
 J.Peterson