

ECONOLITE ASC/3-2070 RAILROAD PREEMPT PROGRAMMING DETAIL

(program controller as shown)

- From Main Menu select **4. PREEMPTOR/TSP**
- From PREEMPTOR/TSP/SCP Submenu select **1. PREEMPT PLAN 1-10**

Place cursor in [] next to Preempt Plan and press 1. Then press the right cursor arrow and toggle the controller to YES. Next cursor down. This will select Railroad Preempt #1.

PREEMPT PLAN [1]	ENABLE....YES
VEH/PED 1 2 3 4 5 6 7 8 9 0 1 2 3 4 5 6	
OVERLAP A B C D E F G H I J K L M N O P	
TRKCLR V X	
TRKCLR O	
ENA TRL	
DWEL VEH . X X	
DWEL PED	
DWEL OLP	
CYC VEH	
CYC PED	
CYC OLP	
EXIT PH X	
EXIT CAL	
SP FUNC	

```

ENABLE... YESIPMT OVRIDE.XIINTERLOCK. NO
DET LOCK... XIDELAY.. 0IINHIBIT... 0
OVERRIDE FL. .IDURATION 0ICLR-GRN... NO
TERM OLP. NOIPC>YEL NOITERM PH NO
PED DARK.. NOITC RESRV YESIDWELL FL OFF
LINK PMT....0IX FLCOLR REDIEXIT OPT. XPH
X TMG PLN...2IRE-SERV.. 0IFLT TYPE.HARD
FREE DUR PMTIR1 NOIR2 NOIR3 NOIR4 NO
--TIMING-----WALKIPED CLIMN GRI YELI RED
ENTRANCE TM. 255I 255I 1125.5125.5
-----MIN GRIEXT GRIMX GRI YELI RED
TRACK CLEAR 25I 0I 0I 3.0I 2.6
-----MIN DLIPMTEXTIMX TMI YELI RED
DWL/CYC-EXIT 12I 0.0I 0I25.5I25.5
PMT ACTIVE OUT..ON PMT ACT DWELL...NO
OTHER - PRI PMT.OFF NON-PRI PMT....OFF
INH EXT TIME... 0.0 PED PR RETURN...OFF
PRIORITY RETURN.OFF QUEUE DELAY.... OFF
COND DELAY.....OFF
PHASES 1 2 3 4 5 6 7 8
PR RTN% 0 0 0 0 0 0 0 0
PHASES 9 10 11 12 13 14 15 16
PR RTN% 0 0 0 0 0 0 0 0
    
```

NOTICE X TMG PLN 2

NOTICE 'XPH'

* NOTE: To ensure Phase 4 has 14 sec of Min Green time during the exit interval, do the following only after all controller Timing Plan 1 phase data has been entered:

- From Main Menu select **8. UTILITIES**
- From UTILITIES Submenu select **1. COPY/CLEAR**
- Copy FROM Timing Plan 1 TO Timing Plan 2
- From Main Menu select **2. CONTROLLER**
- From CONTROLLER Submenu select **1. TIMING PLANS**
- Select Timing Plan 2 and enter 14 for MIN GRN for Phase 4

END PROGRAMMING

RAILROAD PREEMPTION WIRING DETAIL

(wire as shown below)

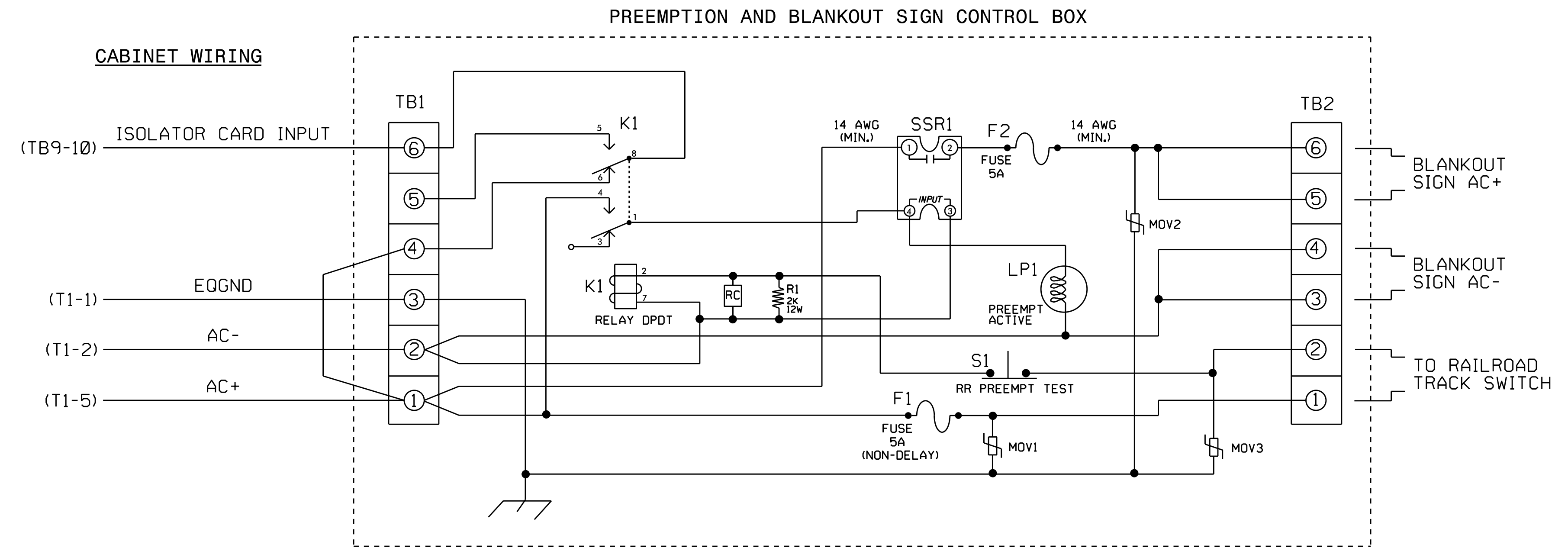

NOTES

- Relay K1 is shown in the energized (Preempt not active) normal operation state.
- Relay K1 is a DPDT with 120VAC coil with octal base.
- Relay SSR1 is a SPST (normally open) Solid State Relay with AC input and AC (25 amp) output.
- AC Isolator Card shall activate preemption upon removal of AC+ from the input (as shown above). To accomplish this set invert dip switch on AC Isolator Card as shown on the detail on sheet 1.
- IMPORTANT!! A jumper must be added between input file terminals J14-E and J14-K if not already present. Also, terminal TB9-12 (on input panel) shall be connected to AC neutral (jumper may have to be added).

FRONT VIEW

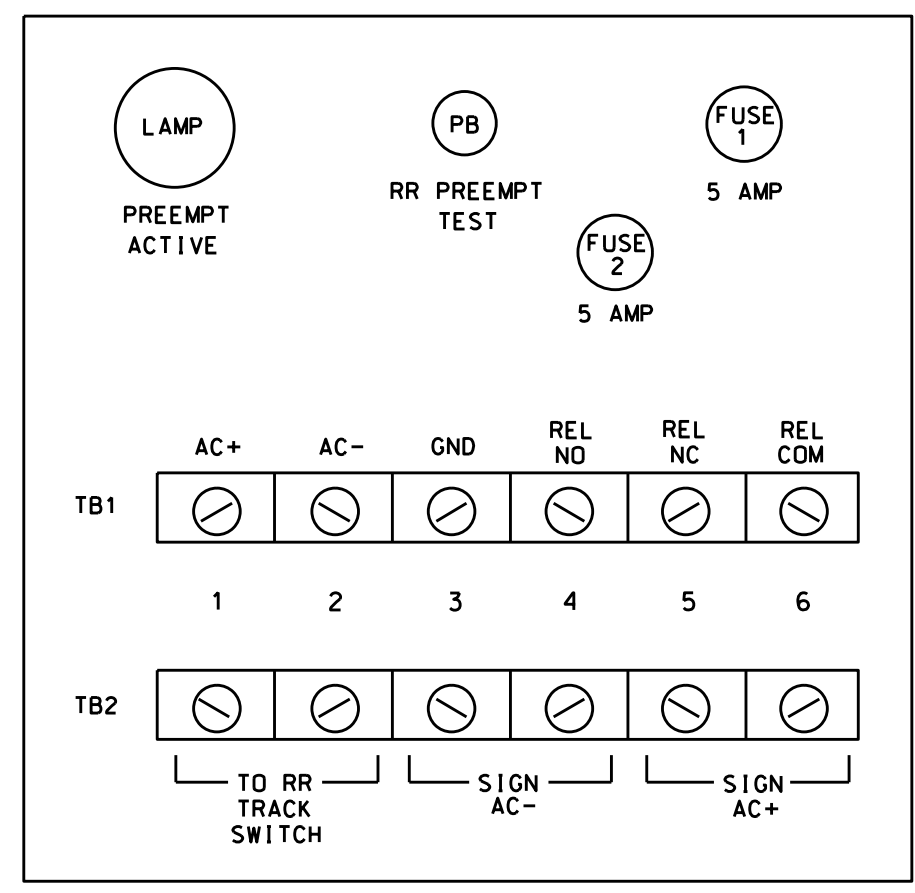

THIS ELECTRICAL DETAIL IS FOR THE SIGNAL DESIGN: 06-0052
 DESIGNED: November 2015
 SEALED: 3/14/2016
 REVISED: N/A

Electrical Detail - Sheet 2 of 2

DOCUMENT NOT CONSIDERED FINAL UNLESS ALL SIGNATURES COMPLETED

US 401 Business (Robeson St) at SR 1168 (Whitfield St)

Division 6 Cumberland County Fayetteville

PLAN DATE: March 2016 REVIEWED BY: BAS

PREPARED BY: S. Armstrong REVIEWED BY:

REVISIONS INIT. DATE

Keith M. Mims 10/6/2016
 2F80786ECC03445 DATE

SIG. INVENTORY NO. 06-0052

06-0052-2016-06-23
 S:\IT\5511\15\SIGNAL\work\hgr\oups\sig\Map\harmstrong\60052_sm.ele.xxx.dgn
 sarmstrong