

EDI MODEL 2018EClip-NC CONFLICT MONITOR

PROGRAMMING DETAIL

(remove jumpers and set switches as shown)

REMOVE DIODE JUMPERS 1-5, 1-6, 1-9, 1-11, 1-15, 2-5, 2-6, 2-9, 2-11, 2-13, 2-15, 3-7, 3-8, 3-10, 3-12, 3-16, 4-7, 4-8, 4-10, 4-12, 4-14, 4-16, 5-9, 5-11, 5-13, 6-9, 6-11, 6-13, 6-15, 7-10, 7-12, 7-14, 8-10, 8-12, 8-14, 8-16, 9-11, 9-13, 9-15, 10-12, 10-14, 10-16, 11-13, 11-15, 12-14, 12-16, 13-15, and 14-16.

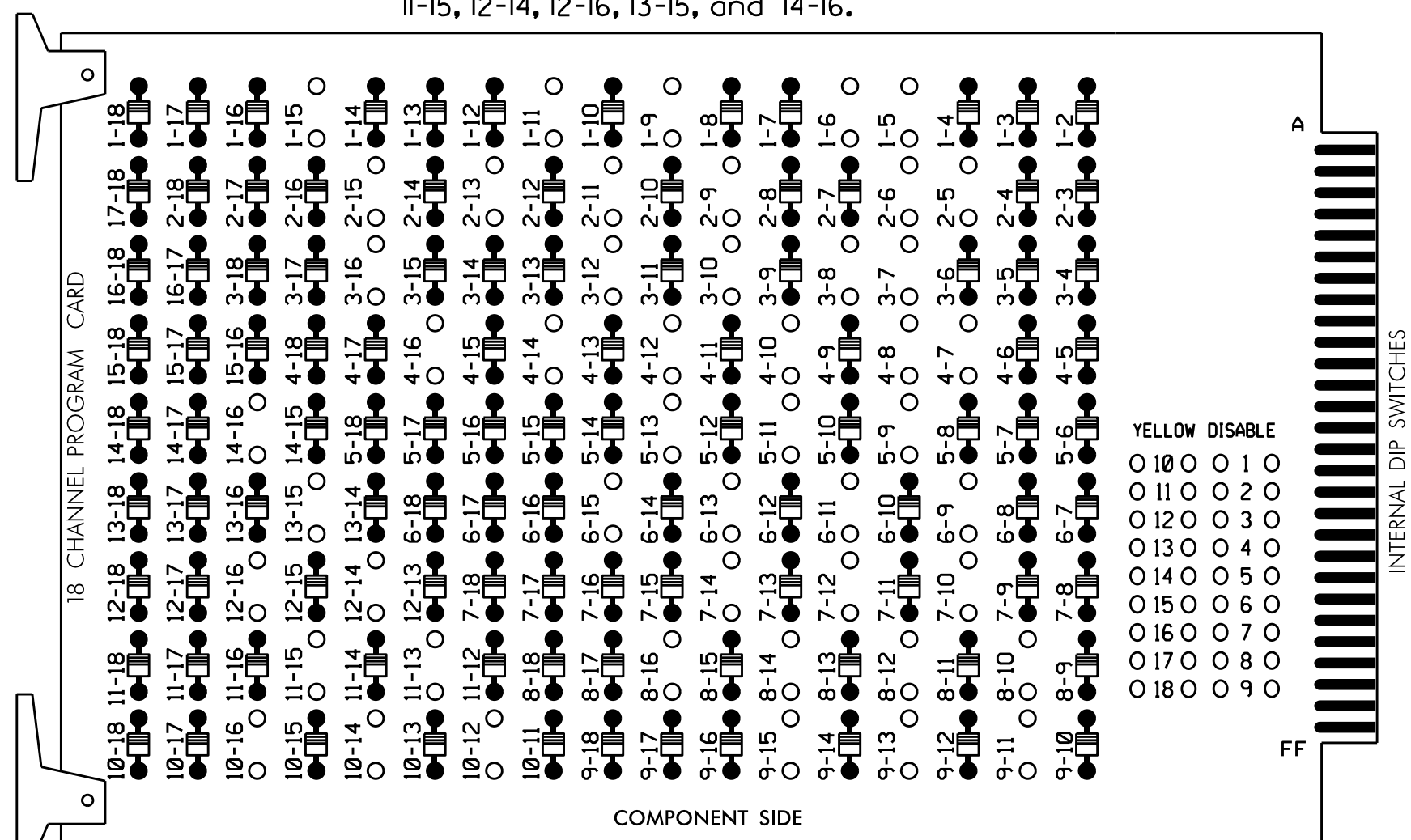

REMOVE JUMPERS AS SHOWN

NOTES:

- Card is provided with all diode jumpers in place. Removal of any jumper allows its channels to run concurrently.
- Ensure jumpers SEL2-SEL5 and SEL9 are present on the monitor board.
- Ensure that Red Enable is active at all times during normal operation.
- Integrate monitor with Ethernet network in cabinet.

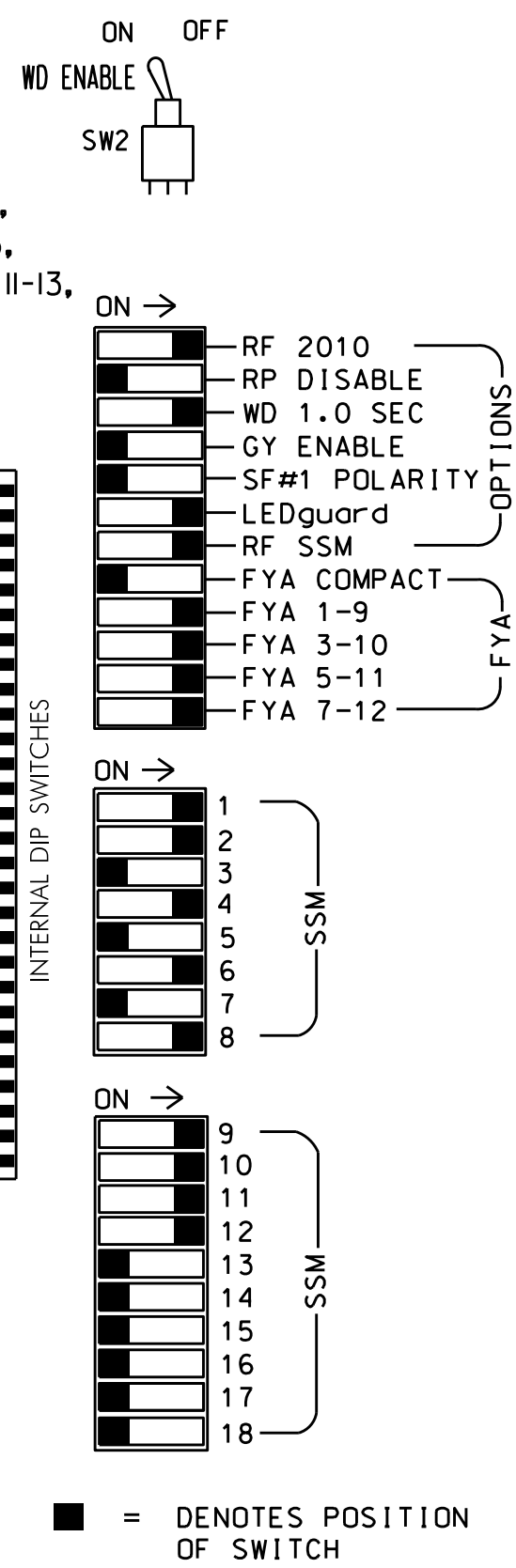

NOTES

- To prevent "flash-conflict" problems, insert red flash program blocks for all unused vehicle load switches in the output file. The installer shall verify that signal heads flash in accordance with the Signal Plans.
- Program phases 4 and 8 for Dual Entry.
- Enable Simultaneous Gap-Out for all phases.
- Program controller to start up in phase 2 Walk and 6 Walk.
- The cabinet and controller are part of the Fayetteville Signal System.

EQUIPMENT INFORMATION

CONTROLLER.....2070E
 CABINET.....332 W/AUX
 SOFTWARE.....ECONOLITE ASC/3-2070
 CABINET MOUNT.....BASE
 OUTPUT FILE POSITIONS...18 WITH AUX. OUTPUT FILE
 LOAD SWITCHES USED.....S1,S2,S3,S4,S5,S6,S7,S8,S9,S10,S11,
 S12,AUX S1,AUX S2,AUX S4,AUX S5
 PHASES USED.....1,2,2PED,3,4,4PED,5,6,6PED,7,8,8PED
 OVERLAP "A".....*
 OVERLAP "B".....*
 OVERLAP "C".....*
 OVERLAP "D".....*
 * See overlap programming detail on sheet 2

SIGNAL HEAD HOOK-UP CHART

LOAD SWITCH NO.	S1	S2	S3	S4	S5	S6	S7	S8	S9	S10	S11	S12	AUX S1	AUX S2	AUX S3	AUX S4	AUX S5	AUX S6	
CMU CHANNEL NO.	1	2	13	3	4	14	5	6	15	7	8	16	9	10	17	11	12	18	
PHASE	1	2	2 PED	3	4	4 PED	5	6	6 PED	7	8	8 PED	OLA	OLB	SPARE	OLC	OLD	SPARE	
SIGNAL HEAD NO.	11	82	21,22	P21, P22	31	41,42	P41, P42	51	61,62	P61, P62	71	81,82	P81, P82	11	31	NU	51	71	NU
RED	*	128			101				134			107							
YELLOW			129	*	102		*	135		*	108								
GREEN			130		103			136			109								
RED ARROW													A121	A124		A114	A101		
YELLOW ARROW		126												A122	A125		A115	A102	
FLASHING YELLOW ARROW														A123	A126		A116	A103	
GREEN ARROW	127	127			118			133			124								
Hand icon					113			104			119			110					
Person icon					115			106			121			112					

NU = Not Used
 * Denotes install load resistor. See load resistor installation detail this sheet.
 * See pictorial of head wiring in detail below.

INPUT FILE POSITION LAYOUT

(front view)

FILE	1	2	3	4	5	6	7	8	9	10	11	12	13	14	
U	∅ 1	∅ 1	∅ 2	∅ 3	∅ 4	∅ 5	∅ 6	∅ 7	∅ 8	∅ 9	∅ 10	∅ 11	∅ 12	∅ 13	∅ 14
L	1A	1B	2A,2B	3A	4A	5A	6A	7A	8A	9A	10A	11A	12A	13A	14A
U	NOT USED	NOT USED	NOT USED	NOT USED	NOT USED	NOT USED	NOT USED	NOT USED	NOT USED	NOT USED	NOT USED	NOT USED	NOT USED	NOT USED	PRE1
L	DC ISOLATOR	DC ISOLATOR	DC ISOLATOR	DC ISOLATOR	DC ISOLATOR	DC ISOLATOR	DC ISOLATOR	DC ISOLATOR	DC ISOLATOR	DC ISOLATOR	DC ISOLATOR	DC ISOLATOR	DC ISOLATOR	DC ISOLATOR	AC ISOLATOR

EX.: 1A, 2A, ETC. = LOOP NO.'S
 FS = FLASH SENSE
 ST = STOP TIME
 PRE1 = RR PREEMPT
 * Wired Input - Do not populate slot with detector card

INPUT FILE CONNECTION & PROGRAMMING CHART

LOOP NO.	LOOP TERMINAL	INPUT FILE POS.	PIN NO.	DETECTOR NO.	NEMA PHASE	CALL	EXTEND TIME	DELAY TIME	DETECTOR TYPE
1A ¹	TB2-1,2	I1U	56	★ 1	1	YES		15	S
	-	J4U	48	★ 26	6	YES			S
1B	TB2-5,6	I2U	39	2	1	YES		15	S
2A,2B	TB2-9,10	I3U	63	32	2	YES			S
3A ²	TB4-5,6	I5U	58	★ 3	3	YES		15	S
	-	J8U	50	★ 28	8	YES			S
4A	TB4-9,10	I6U	41	4	4	YES			S
4B	TB4-11,12	I6L	45	14	4	YES		10	S
5A ³	TB3-1,2	J1U	55	★ 5	5	YES		15	S
	-	I4U	47	★ 22	2	YES			S
6A,6B	TB3-5,6	J2U	40	6	6	YES			S
7A ⁴	TB5-5,6	J5U	57	★ 7	7	YES		15	S
	-	I8U	49	★ 24	4	YES			S
8A	TB5-9,10	J6U	42	8	8	YES			S
PED PUSH BUTTONS									
P21,P22	TB8-4,6	I12U	67	PED 2	2 PED				
P41,P42	TB8-5,6	I12L	69	PED 4	4 PED				
P61,P62	TB8-7,9	I13U	68	PED 6	6 PED				
P81,P82	TB8-8,9	I13L	70	PED 8	8 PED				

NOTE:
 INSTALL DC ISOLATORS IN INPUT FILE SLOTS 112 AND 113.

- * For the detectors to work as shown on the signal design plan, see the Vehicle Detector Setup Programming Detail for Alternate Phasing on sheets 3 and 4.

- Add jumper from I1-W to J4-W, on rear of input file.
- Add jumper from I5-W to J8-W, on rear of input file.
- Add jumper from J1-W to I4-W, on rear of input file.
- Add jumper from J5-W to I8-W, on rear of input file.

INPUT FILE POSITION LEGEND: J2L

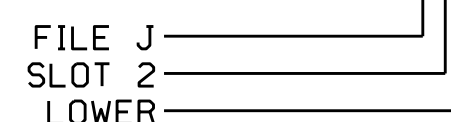

FYA SIGNAL WIRING DETAIL

(wire signal heads as shown)

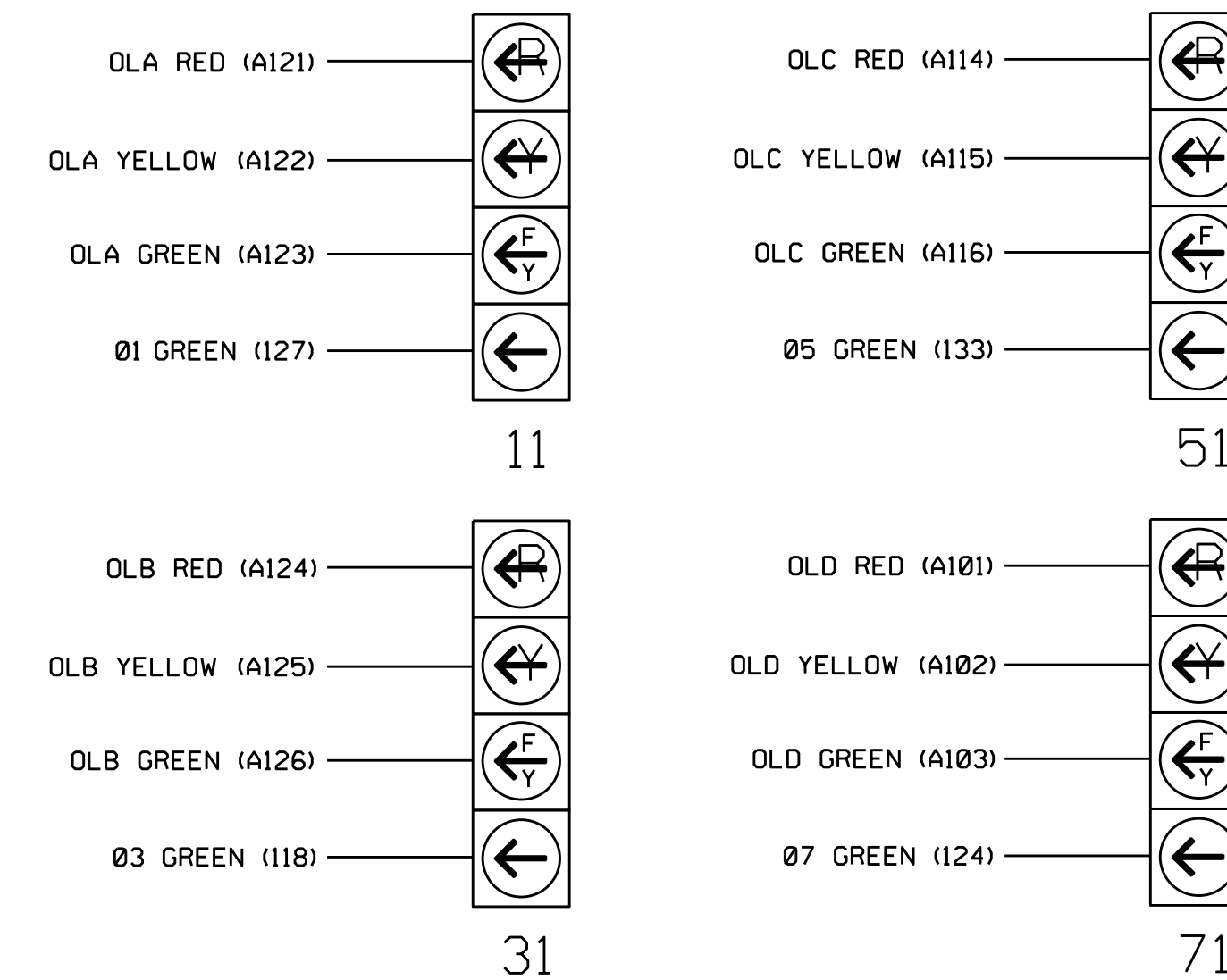

THIS ELECTRICAL DETAIL IS FOR THE SIGNAL DESIGN: 06-0014
 DESIGNED: April 2016
 SEALED: 9/27/2016
 REVISED: N/A

LOAD RESISTOR INSTALLATION DETAIL

(install resistors as shown)

VALUE (ohms)	WATTAGE
1.5K - 1.9K	25W (min)
2.0K - 3.0K	10W (min)

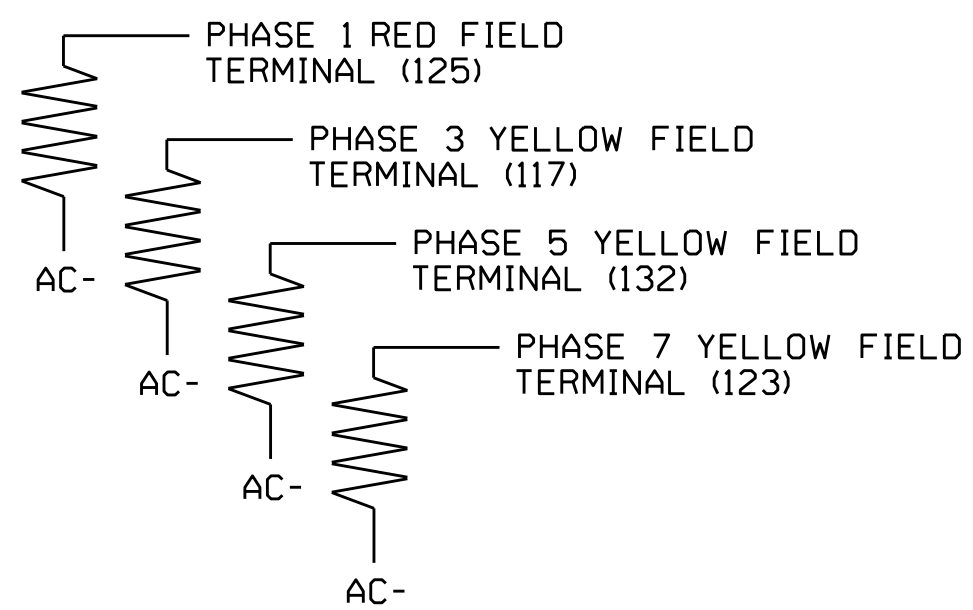

Electrical Detail - Sheet 1 of 6

DOCUMENT NOT CONSIDERED FINAL UNLESS ALL SIGNATURES COMPLETED

Prepared In the Offices of:
 TRANSPORTATION MOBILITY AND SAFETY DIVISION
 NORTH CAROLINA DEPARTMENT OF TRANSPORTATION
 Signal Management Section
 750 N. Greenfield Pkwy, Garner, NC 27529

SR 2299 (Russell Street) at SR 2311 (Gillespie Street)

Division 6 Cumberland County Fayetteville
 PLAN DATE: September 2016 REVIEWED BY: BAS
 PREPARED BY: S. Armstrong REVIEWED BY:
 REVISIONS INIT. DATE
 Keith M. Mims 10/13/2016
 SIG. INVENTORY NO. 06-0014