

**This electronic collection of documents is provided
for the convenience of the user
and is Not a Certified Document –**

**The documents contained herein were originally issued
and sealed by the individuals whose names and license
numbers appear on each page, on the dates appearing
with their signature on that page.**

**This file or an individual page
shall not be considered a certified document.**

| | | | |
|---|--|--|--|
| PROJECT REFERENCE NO. R-4753 | | SHEET NO. W-1 | |
| GEOTECHNICAL ENGINEER  RICHARD S. WEBB | | ENGINEER _____ SIGNATURE | |
| Designed by Scott Webb DATE: 9/13/2016 | | DATE: _____ SIGNATURE: _____ DATE: _____ | |

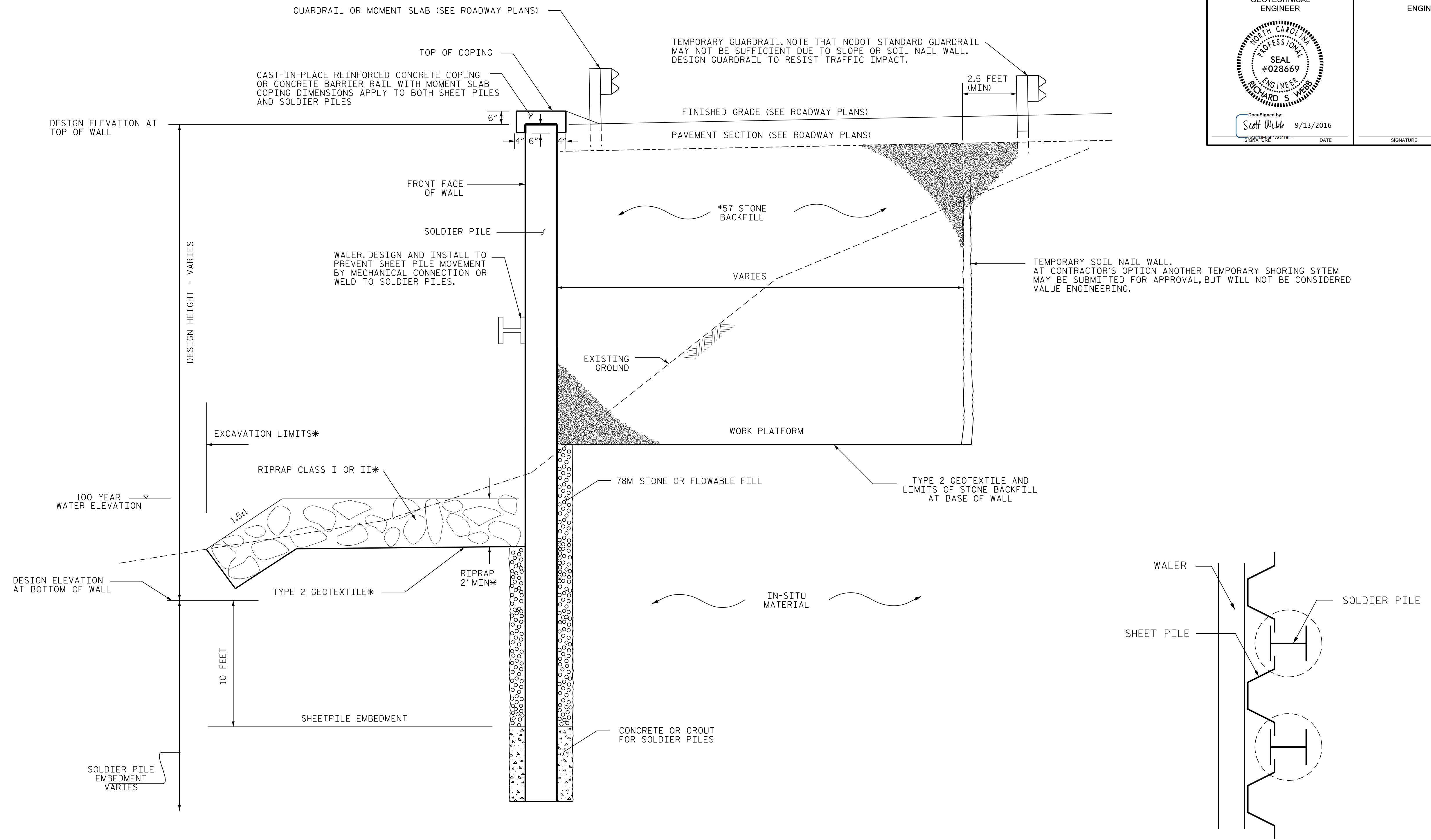

CANTILEVERED SHEET PILE WALL - TYPICAL SECTION

SHEET PILE WALL

NOT TO SCALE
 WORK PLATFORMS AND TEMPORARY SOIL NAIL WALL MAY BE OMITTED WHERE NOT NEEDED
 *ONLY IF CONTRACTOR EXCAVATES BELOW 100 YEAR WATER ELEVATION FOR WORK PLATFORM OUTSIDE WALL

| | |
|----------------------|----------------|
| PREPARED BY: RSW | DATE: 9/8/2016 |
| REVIEWED BY: MAM/SCC | DATE: 9/8/2016 |

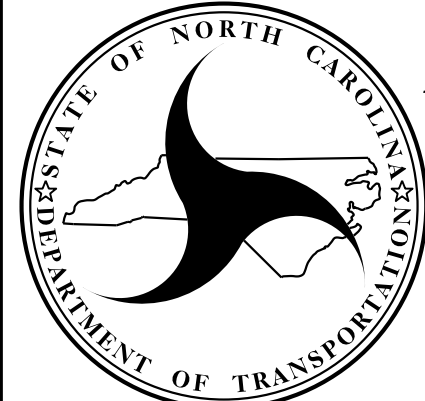

**NORTH CAROLINA
 DEPARTMENT OF TRANSPORTATION
 DIVISION OF HIGHWAYS**

**GEOTECHNICAL
 ENGINEERING UNIT**

| CANTILEVERED SHEET PILE WALL | | | | | |
|------------------------------|----|------|-----|----|------|
| REVISIONS | | | | | |
| NO. | BY | DATE | NO. | BY | DATE |
| 1 | | | 3 | | |
| 2 | | | 4 | | |

| | | | |
|--|--|---|--|
| PROJECT REFERENCE NO. R-4753 | | SHEET NO. W-2 | |
| GEOTECHNICAL ENGINEER  Designed by: <i>Scott Webb</i> 9/13/2016 | | ENGINEER DATE _____ SIGNATURE _____ DATE _____ | |

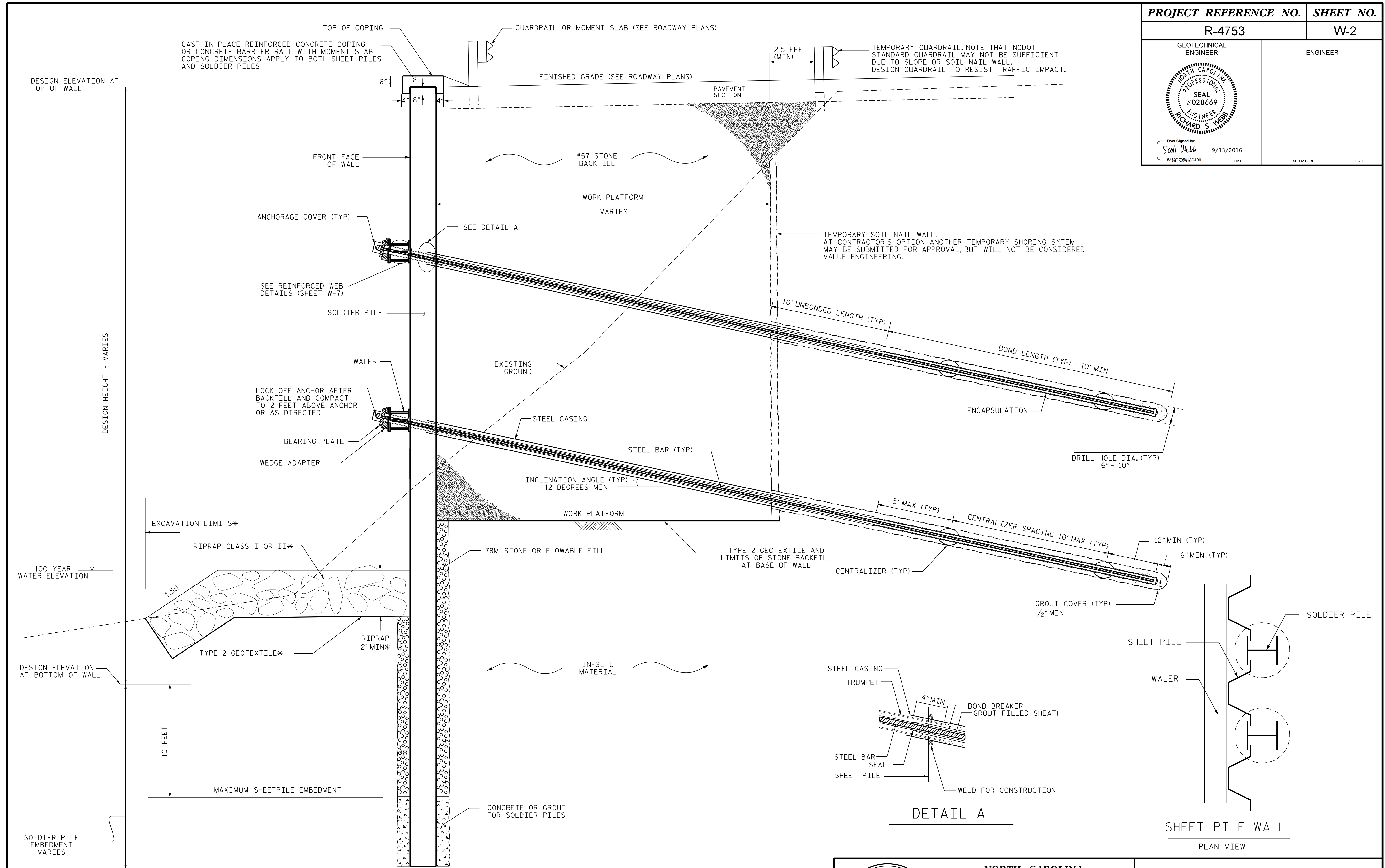

| | |
|----------------------|----------------|
| PREPARED BY: RSW | DATE: 9/8/2016 |
| REVIEWED BY: MAM/SCC | DATE: 9/8/2016 |

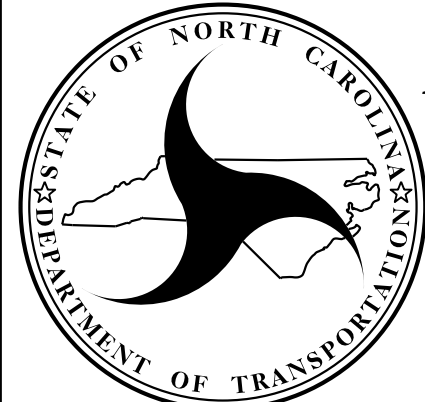

**NORTH CAROLINA
DEPARTMENT OF TRANSPORTATION
DIVISION OF HIGHWAYS**

**GEOTECHNICAL
ENGINEERING UNIT**

ANCHORED SHEET PILE WALL

| REVISIONS | | | | | |
|-----------|----|------|-----|----|------|
| NO. | BY | DATE | NO. | BY | DATE |
| 1 | | | 3 | | |
| 2 | | | 4 | | |

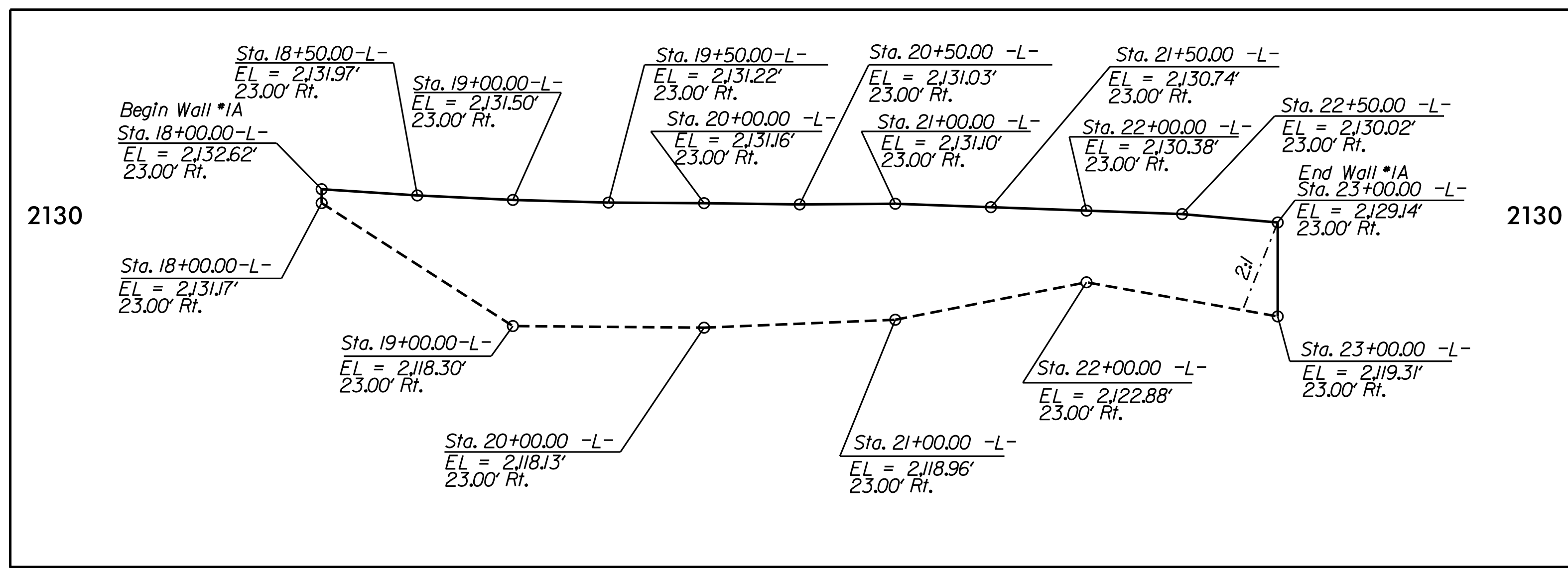

RETAINING WALL 1A ENVELOPE
Sta. 18+00.00 -L- to Sta. 23+00.00 -L-

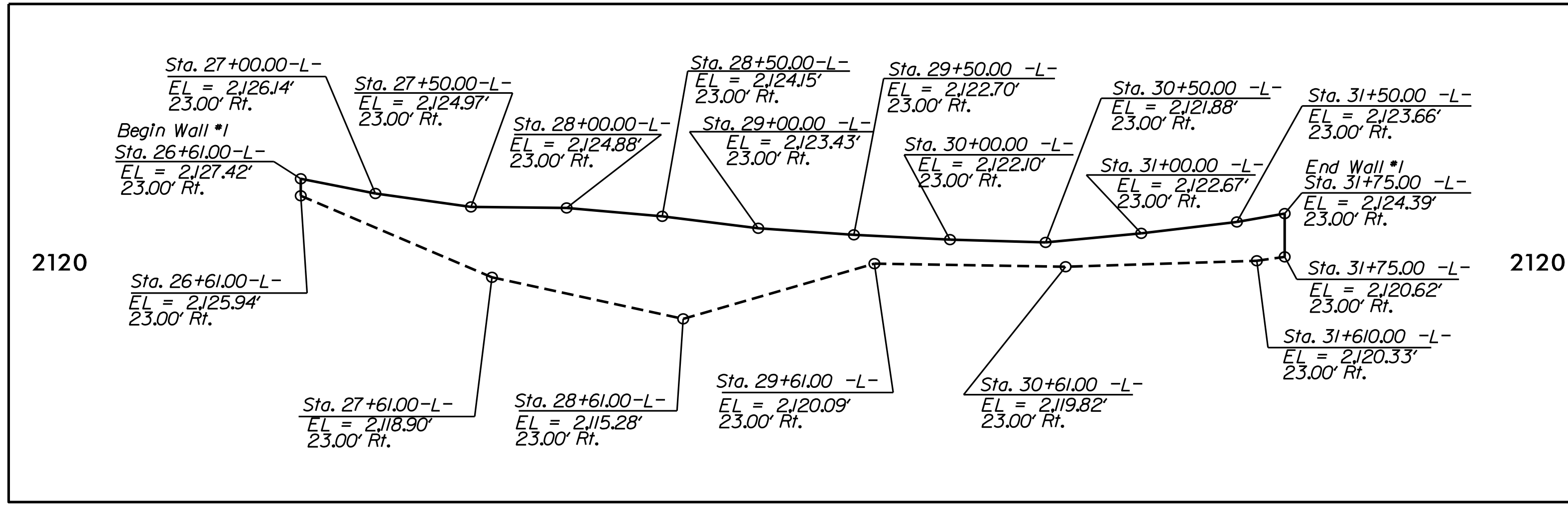

RETAINING WALL 1 ENVELOPE
Sta. 26+61.00 -L- to Sta. 31+75.00 -L-

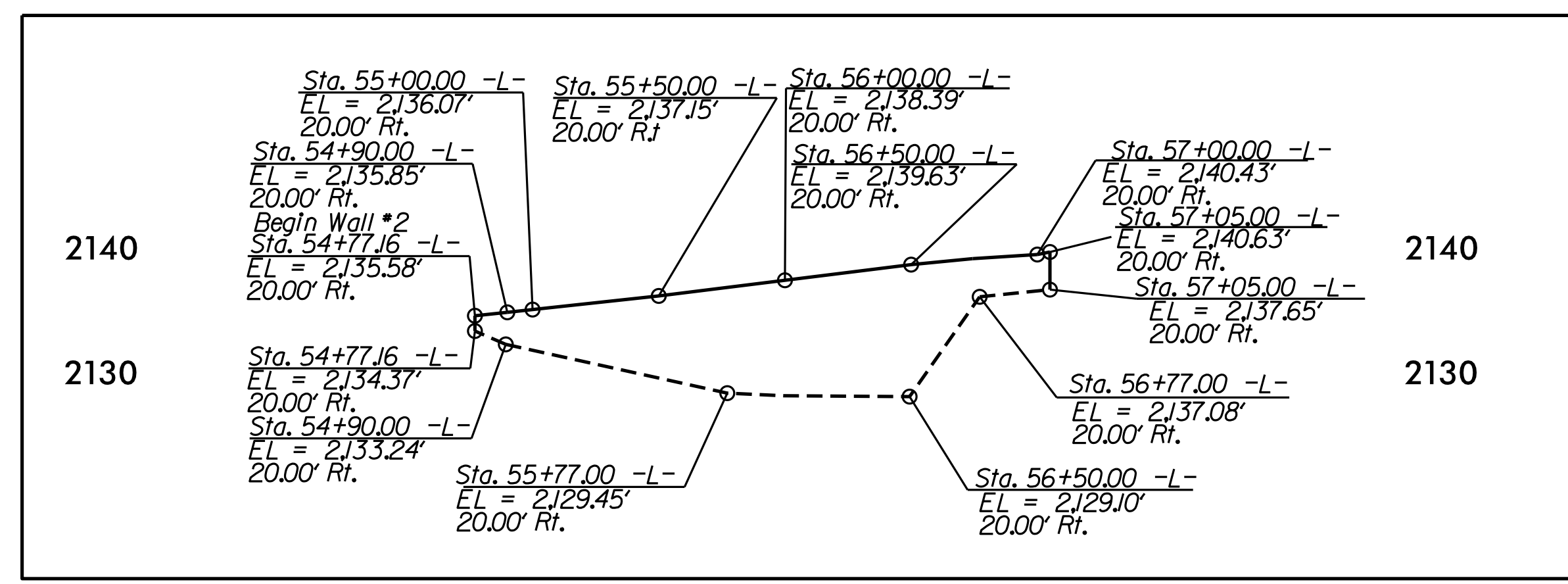

RETAINING WALL 2 ENVELOPE
Sta. 54+77.16 -L- to Sta. 57+05.00 -L-

LEGEND

- DESIGN ELEVATION AT TOP OF WALL
- EXISTING GROUND FROM NCDOT SURVEY MARCH 2016
- FILL SLOPE

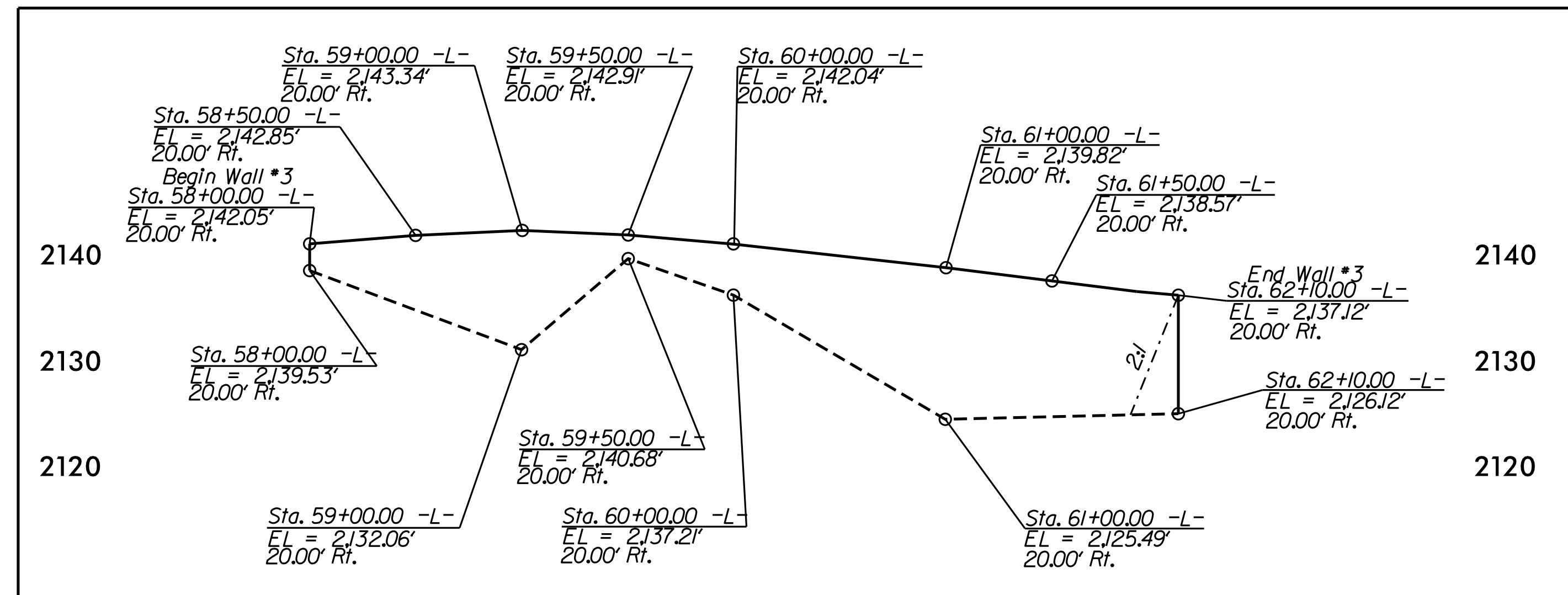

RETAINING WALL 3 ENVELOPE
Sta. 58+00.00 -L- to Sta. 62+10.00 -L-

LEGEND

- DESIGN ELEVATION AT TOP OF WALL
- - - - - EXISTING GROUND FROM NCDOT SURVEY MARCH 2016
- FILL SLOPE

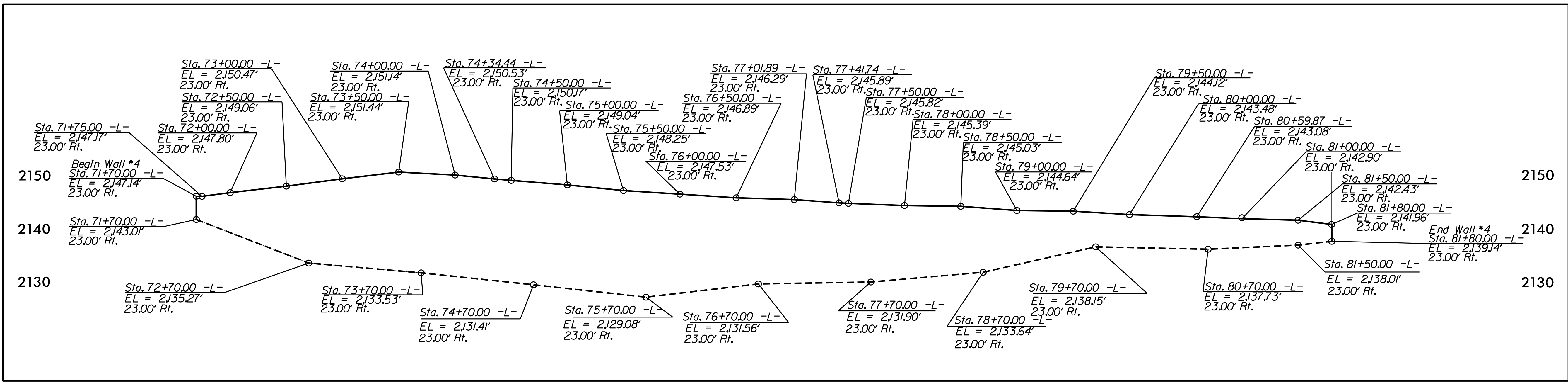

RETAINING WALL ENVELOPE 4
Sta. 71+70.00 -L- to Sta. 81+80.00 -L-

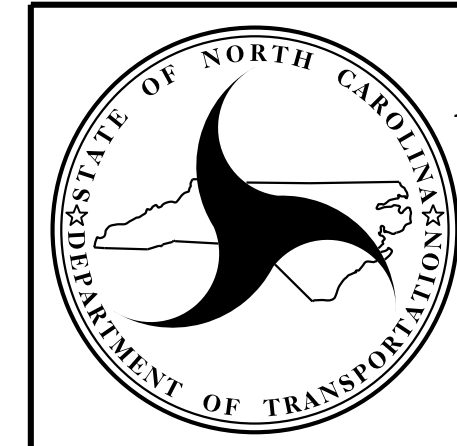

| | | |
|--|--|-------------------------|
| PROJECT REFERENCE NO. R-4753 | | SHEET NO. W-6 |
| GEOTECHNICAL ENGINEER  DocuSigned by: Scott Webb 1/3/2017 | | ENGINEER |
| SIGNATURE | | DATE |

NOTES:

- FOR PILE WALLS WITH OPTIONS, SEE PILE WALLS WITH OPTIONS PROVISION.
- A CONCRETE BARRIER RAIL WITH MOMENT SLAB IS REQUIRED ABOVE RETAINING WALL NO. 2 AND 3. SEE PLANS FOR CONCRETE BARRIER RAIL WITH MOMENT SLAB DETAILS. MODIFY CONCRETE BARRIER RAIL WITH MOMENT SLAB DETAILS TO ACCOMMODATE RETAINING WALLS AS NEEDED.
- BEFORE BEGINNING WALL DESIGN FOR RETAINING WALL NO. 1A, 1, 2, 3, 4, 5, 6, 7A & 7B, SURVEY WALL LOCATION AND SUBMIT A REVISED WALL PROFILE VIEW (WALL ENVELOPE) FOR REVIEW. DO NOT START WALL DESIGN OR CONSTRUCTION UNTIL THE REVISED WALL ENVELOPE IS ACCEPTED.
- DESIGN RETAINING WALL NO. 1A, 1, 2, 3, 4, 5, 6, 7A & 7B FOR THE FOLLOWING:
 - DESIGN LIFE = 75 YEARS
 - *57 STONE BACKFILL PARAMETERS:
UNIT WEIGHT, $\gamma = 110$ LB/CF
FRICTION ANGLE, $\phi = 38$ DEGREES
COHESION, $c = 0$ LB/SF
 - SOIL ASSUMED MATERIAL PARAMETERS:
UNIT WEIGHT, $\gamma = 120$ LB/CF
FRICTION ANGLE, $\phi = 28$ DEGREES
COHESION, $c = 0$ LB/SF
 - ROCK ASSUMED MATERIAL PARAMETERS:
UNIT WEIGHT, $\gamma = 145$ LB/CF
FRICTION ANGLE, $\phi = 39$ DEGREES
COHESION, $c = 0$ LB/SF
- SEE PILE WALL WITH OPTIONS PROVISION FOR DETERMINING ROCK ELEVATION.
- DESIGN RETAINING WALL NO. 1A, 1, 2, 3, 4, 5, 6, 7A & 7B FOR A LIVE LOAD (TRAFFIC) SURCHARGE.
- DESIGN RETAINING WALLS FOR PIPE EXTENDING UNDER OR THROUGH THE WALL AT THE FOLLOWING LOCATIONS: 28+59, 30+53, 31+30, 76+91, 150+04 AND 151+76. BEFORE BEGINNING WALL DESIGN OR CONSTRUCTION, VERIFY PIPE LOCATION AND ELEVATION. COORDINATE PLANS AND DETAILS WITH THE UTILITY DRAINAGE CONTRACTOR. ENSURE PIPE OUTLET DOES NOT WASHOUT THE FRONT SLOPE OF THE WALL. SUBMIT PLANS AND DETAILS FOR REVIEW.
- EXISTING OR FUTURE OBSTRUCTIONS SUCH AS FOUNDATIONS, GUARDRAIL, FENCE OR HANDRAIL POSTS, PAVEMENTS, PIPES, INLETS OR UTILITIES MAY INTERFERE WITH GROUND ANCHORS FOR RETAINING WALL NO. 1A, 1, 2, 3, 4, 5, 6, 7A & 7B.
- "TEMPORARY SHORING" MAY BE REQUIRED FOR RETAINING WALL NO. 1A, 1, 2, 3, 4, 5, 6, 7A & 7B CONSTRUCTION IN ACCORDANCE WITH THE TEMPORARY SOIL NAIL SHORING PROVISION. SEE TRAFFIC CONTROL PLANS.
- LOCATION OF PERFORMANCE TESTS TO BE DETERMINED BY ENGINEER.
- NO VALUE ENGINEERING WILL BE ALLOWED FOR THE TEMPORARY SOIL NAIL WALL. NO PAYMENT WILL BE MADE FOR TEMPORARY SOIL NAIL WALL INSTALLATION BELOW DESIGN ELEVATION.
- FOR PERMANENT DESIGN CONDITION USE 100 YEAR WATER ELEVATION. FOR TEMPORARY DESIGN CONDITION USE 100 YEAR WATER ELEVATION MINUS FOUR FEET.
- USE CANTILEVERED SHEET PILE, ANCHORED SHEET PILE, CANTILEVERED PANEL WALL OR ANCHORED PANEL WALL TYPICAL SECTION AT THE DESIGNER'S CHOICE.
- SHEET PILES SHALL EXTEND TO 10 FEET BELOW BOTTOM OF WALL ELEVATION OR REFUSAL AT ROCK ELEVATION. PRIMARY (SOFT) PILES SHALL EXTEND TO 10 FEET BELOW BOTTOM OF WALL ELEVATION OR 2 FEET BELOW ROCK ELEVATION. SEE PILE WALLS WITH OPTIONS PROVISION TO DETERMINE ROCK ELEVATION.
- WELD TO EACH WALL A STEEL SIGN, SATISFACTORY TO THE ENGINEER, SHOWING THE FINAL GRADE ELEVATION AT OUTSIDE OF WALL AND DEPTH TO THE DESIGN ELEVATION. EMBOSS OR ENGRAVE THE SIGN.
- NOTE THAT BOULDERS MAY BE PRESENT THROUGHOUT THE PROJECT SITE. THE PRESENCE OF BOULDERS SHALL NOT BE CONSIDERED A CHANGED CONDITION.
- NCDOT SHOULD INSPECT PILE WALLS WITH OPTIONS AFTER MAJOR STORM EVENTS AND ON EVIDENCE OF EXCESSIVE EROSION NCDOT SHOULD TAKE APPROPRIATE ACTION.

EXAMPLE CONSTRUCTION SEQUENCE FOR ANCHORED SHEET PILE WALLS:

- INSTALL TEMPORARY SOIL NAIL WALL AND EXCAVATE FOR WORK PLATFORM, IF NECESSARY.
- PERFORM VERIFICATION TESTS ON THE SOIL NAIL WALL TO 1.25 DESIGN CAPACITY.
- INSTALL SOLDIER PILES, SOFT PILES, SHEET PILES AND WALERS.
- INSTALL BOTTOM ROW OF ANCHORS.
- PROOF TEST ANCHORS TO 1.25 DESIGN CAPACITY.
- INSTALL ANCHOR CASING. (IF USING TURNBUCKLE, INSTALL TURNBUCKLE AND TIE ROD).
- GROUT REMAINING LENGTH OF ANCHOR.
- INSTALL ANCHOR HEAD AND STRESS TO PREVENT MOVEMENT.
- BACKFILL AND COMPACT UNTIL AT LEAST 2 FEET ABOVE BOTTOM ANCHOR ELEVATION. USE CAUTION WHEN BACKFILLING AROUND ANCHORS.
- LOCK OFF LOWEST ANCHOR ROW.
- BACKFILL TO TOP ANCHOR ROW ELEVATION. (IF THERE IS NO TOP ANCHOR ROW BACKFILL TO GRADE)
- REPEAT STEPS 4 THROUGH 8 FOR SECOND ANCHOR ROW.
- BACKFILL AND COMPACT TO GRADE.
- LOCK OFF SECOND ANCHOR ROW.
- INSTALL COPING OR MOMENT SLAB.
- THE SOIL NAIL WALL WILL STAY IN PLACE.

EXAMPLE CONSTRUCTION SEQUENCE FOR CANTILEVERED SHEET PILE WALLS:

- INSTALL TEMPORARY SOIL NAIL WALL AND EXCAVATE FOR WORK PLATFORM, IF NECESSARY.
- INSTALL SOLDIER PILES, SOFT PILES, SHEET PILES AND WALERS.
- BACKFILL TO GRADE AND COMPACT.
- INSTALL COPING OR MOMENT SLAB.
- THE SOIL NAIL WALL WILL STAY IN PLACE.

| 100 YEAR WATER ELEVATION | | |
|--------------------------|------------|------------------|
| RETAINING WALL NO. | STATION | ELEVATION (FEET) |
| 1A | 18+00 -L- | 2114.4 |
| 1A | 23+00 -L- | 2115.4 |
| 1 | 26+61 -L- | 2116.2 |
| 1 | 31+75 -L- | 2117.1 |
| 2 | 54+77 -L- | 2123.1 |
| 2 | 57+05 -L- | 2123.4 |
| 3 | 58+00 -L- | 2123.6 |
| 3 | 62+10 -L- | 2124.0 |
| 4 | 71+70 -L- | 2125.3 |
| 4 | 81+80 -L- | 2127.0 |
| 5 | 92+10 -L- | 2129.8 |
| 5 | 95+75 -L- | 2130.8 |
| 6 | 128+35 -L- | 2135.8 |
| 6 | 133+35 -L- | 2136.5 |
| 7A | 148+25 -L- | 2138.0 |
| 7B | 153+05 -L- | 2139.0 |

| ESTIMATED WALL QUANTITIES | |
|----------------------------|-------------------------|
| RETAINING WALL NO. | WALL AREA (SQUARE FEET) |
| 1A | 10700 |
| 1 | 7800 |
| 2 | 3700 |
| 3 | 11300 |
| 4 | 31000 |
| 5 | 8000 |
| 6 | 13000 |
| 7A | 1500 |
| 7B | 3500 |
| TOTAL QUANTITY = 90,400 SF | |

| WALL STATION LIMITS DESIGN ELEVATION | | |
|--------------------------------------|--|------------------------------------|
| RETAINING WALL NO. | STATION LIMITS | DESIGN ELEVATION AT BOTTOM OF WALL |
| 1A | Sta. 18+00.00 -L- to Sta. 23+00.00 -L- | 2110 |
| 1 | Sta. 26+61.00 -L- to Sta. 27+50.00 -L- | 2110 |
| 1 | Sta. 27+50.00 -L- to Sta. 28+00.00 -L- | 2109 |
| 1 | Sta. 28+00.00 -L- to Sta. 28+75.00 -L- | 2108 |
| 1 | Sta. 28+75.00 -L- to Sta. 31+75.00 -L- | 2107 |
| 2 | Sta. 54+77.16 -L- to Sta. 57+05.00 -L- | 2122 |
| 3 | Sta. 58+00.00 -L- to Sta. 59+50.00 -L- | 2115 |
| 3 | Sta. 59+50.00 -L- to Sta. 62+10.00 -L- | 2112 |
| 4 | Sta. 71+70.00 -L- to Sta. 74+50.00 -L- | 2115 |
| 4 | Sta. 74+50.00 -L- to Sta. 78+00.00 -L- | 2116 |
| 4 | Sta. 78+00.00 -L- to Sta. 80+00.00 -L- | 2117 |
| 4 | Sta. 80+00.00 -L- to Sta. 81+80.00 -L- | 2118 |
| 5 | Sta. 92+10.00 -L- to Sta. 95+75.00 -L- | 2119 |
| 6 | Sta. 128+35.00 -L- to Sta. 129+00.00 -L- | 2129 |
| 6 | Sta. 129+00.00 -L- to Sta. 129+50.00 -L- | 2127 |
| 6 | Sta. 129+50.00 -L- to Sta. 133+35.00 -L- | 2125 |
| 7A | Sta. 148+25.00 -L- to Sta. 149+50.00 -L- | 2130 |
| 7B | Sta. 150+50.00 -L- to Sta. 153+05.00 -L- | 2131 |

| | |
|----------------------|----------------|
| PREPARED BY: RSW | DATE: 9/8/2016 |
| REVIEWED BY: MSM/SCC | DATE: 9/8/2016 |



**NORTH CAROLINA
DEPARTMENT OF TRANSPORTATION
DIVISION OF HIGHWAYS**

**GEOTECHNICAL
ENGINEERING UNIT**

| WALL NOTES AND DETAILS | | | | | |
|------------------------|----|------|-----|----|------|
| REVISIONS | | | | | |
| NO. | BY | DATE | NO. | BY | DATE |
| 1 | | | 3 | | |
| 2 | | | 4 | | |

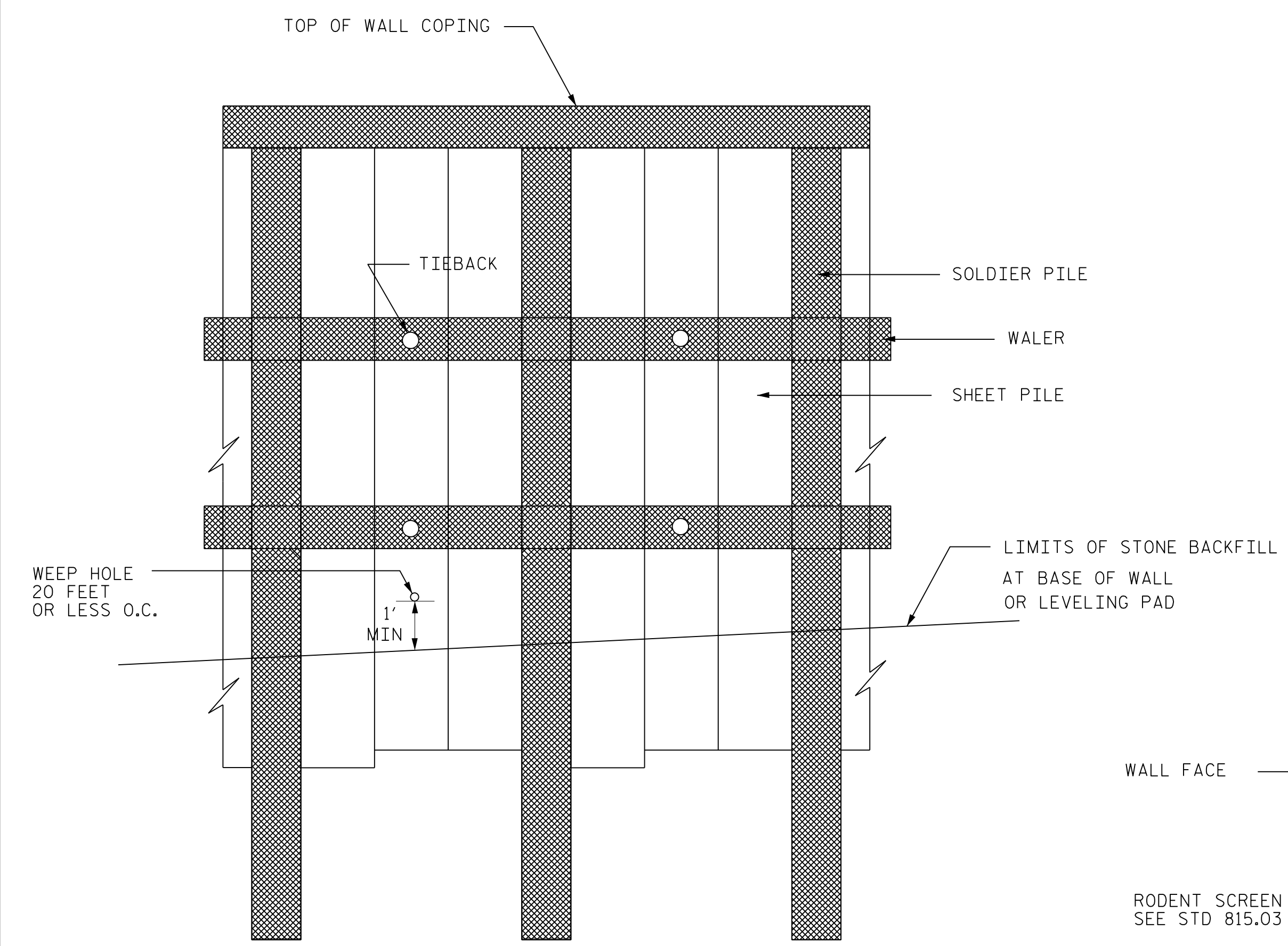

ANCHORED WALL ELEVATION VIEW
(BOTTOM OF WALL NOT SHOWN)

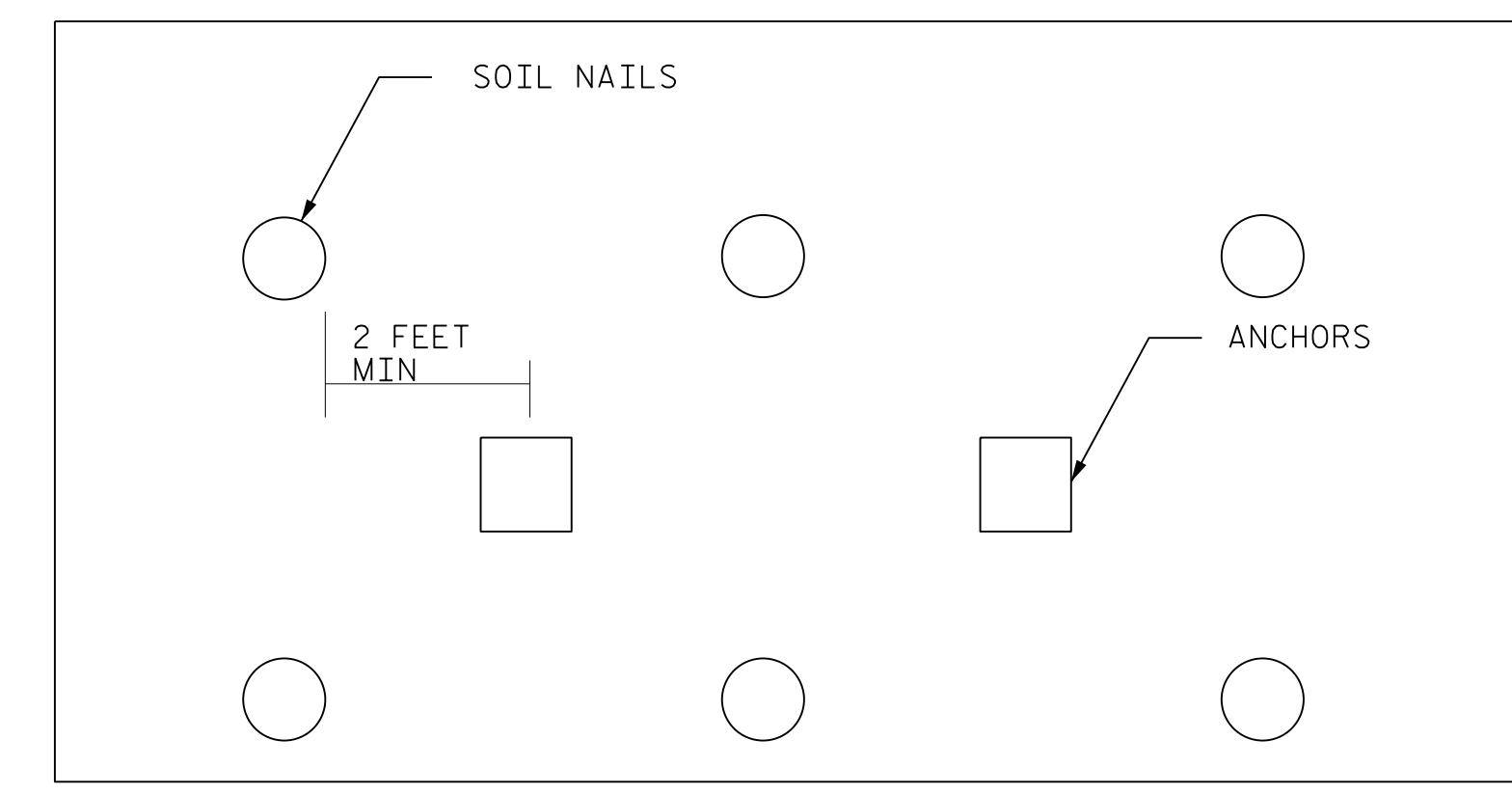

ANCHOR LOCATIONS

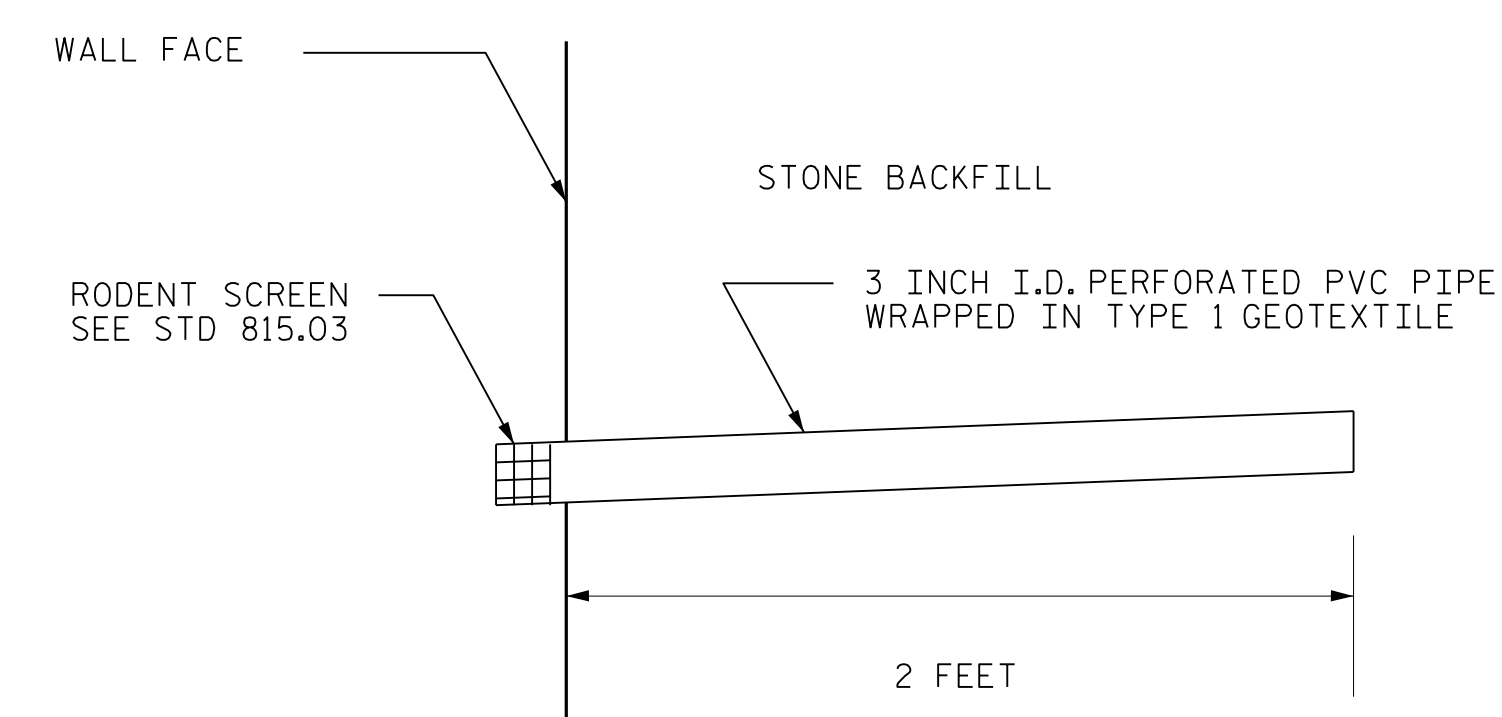

WEEP HOLE DETAIL
FOR PANELS AND SHEET PILES

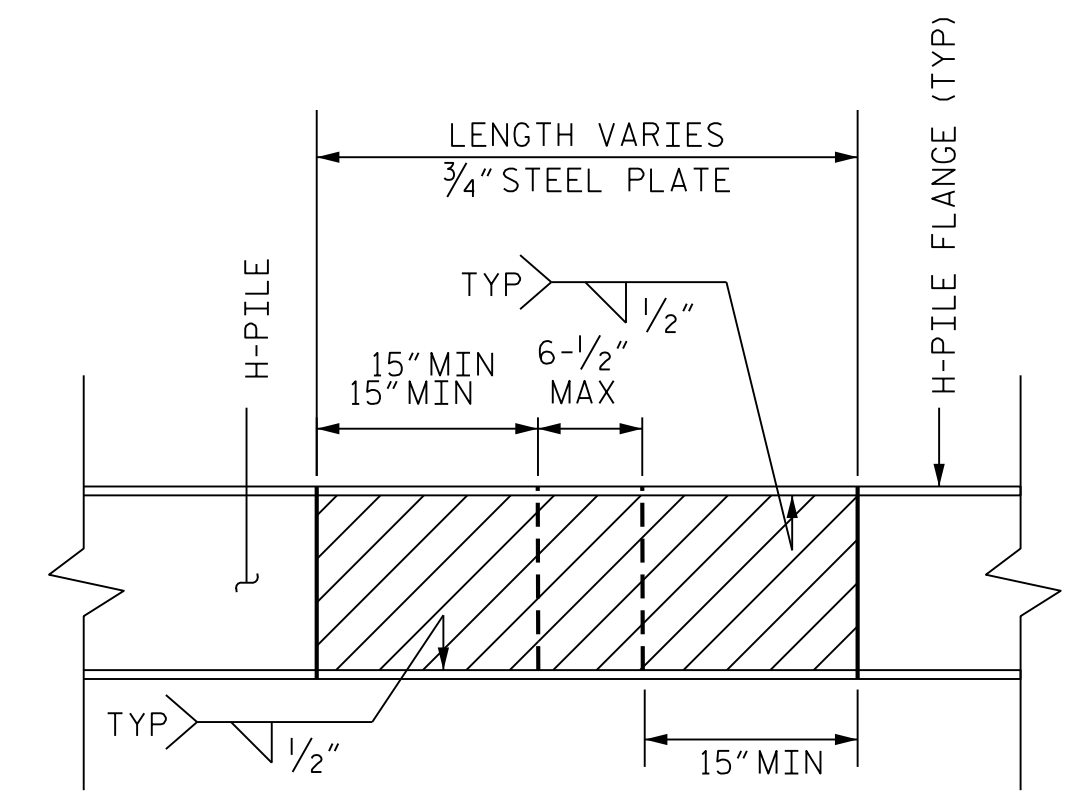

TOP VIEW

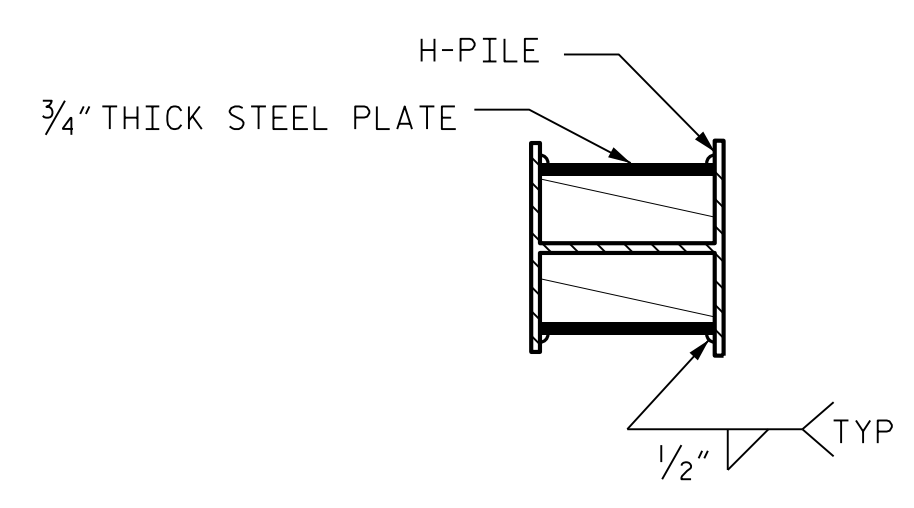

SECTION A-A

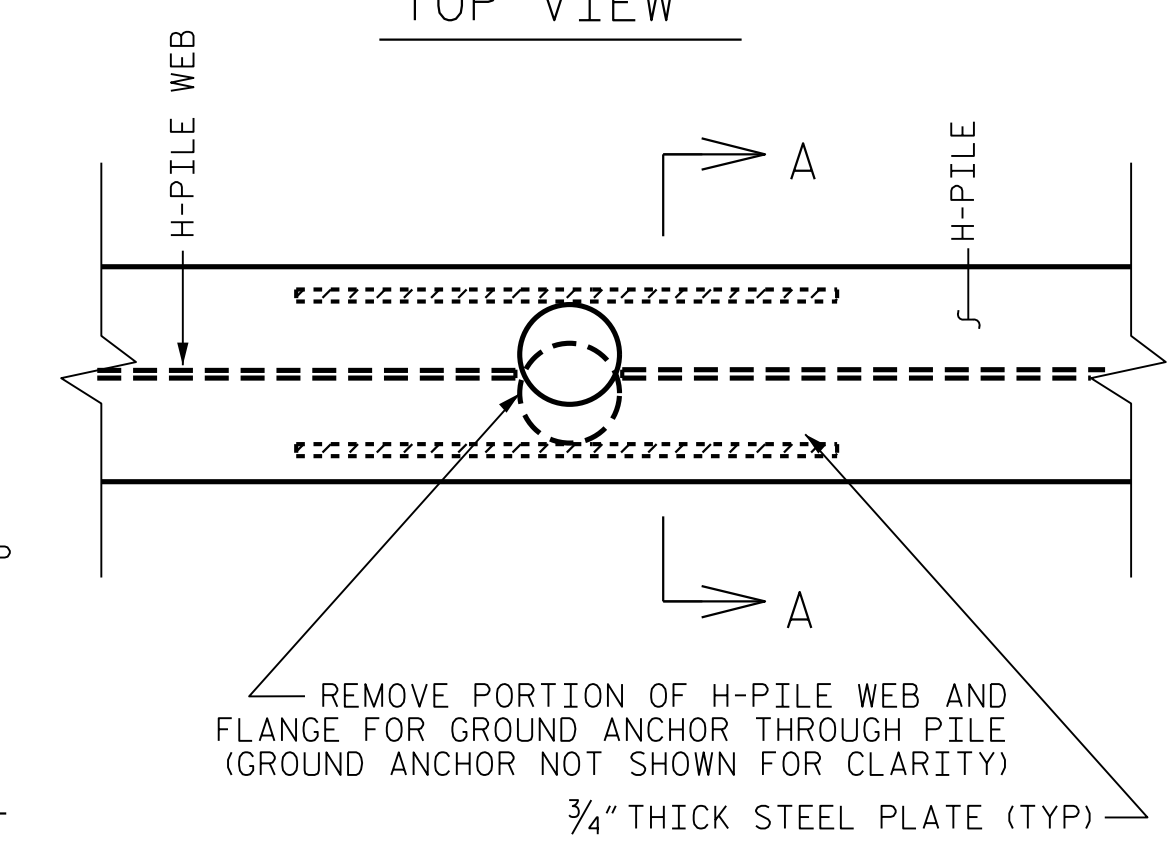

FRONT VIEW

EXAMPLE REINFORCED WEB DETAILS

DETAILS SHOWN ARE FOR ILLUSTRATIVE PURPOSES ONLY.
SUBMIT DETAILS FOR APPROVAL.

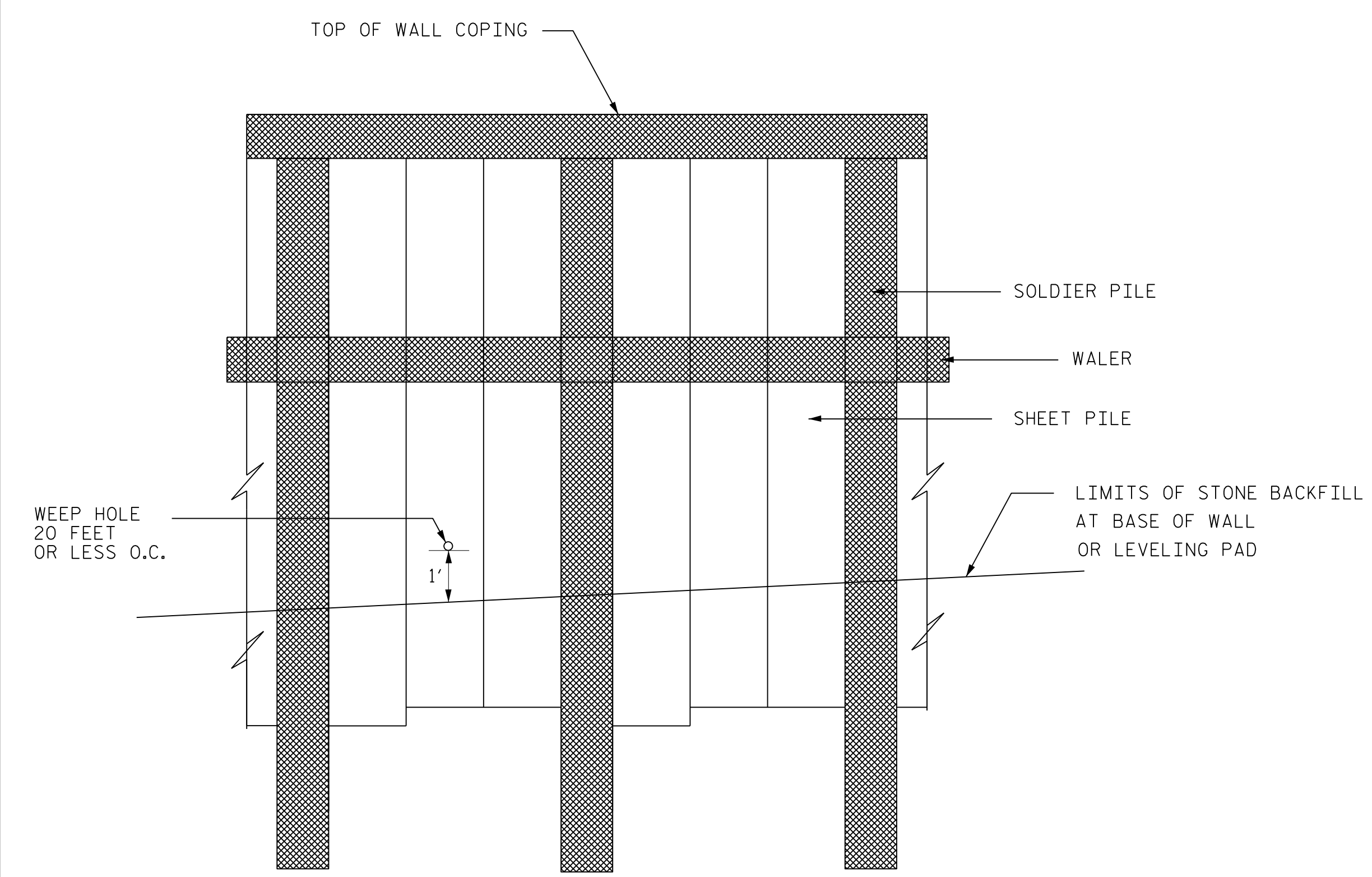

CANTILEVERED WALL ELEVATION VIEW
(BOTTOM OF WALL NOT SHOWN)

| | |
|----------------------|----------------|
| PREPARED BY: RSW | DATE: 9/8/2016 |
| REVIEWED BY: MAM/SCC | DATE: 9/8/2016 |

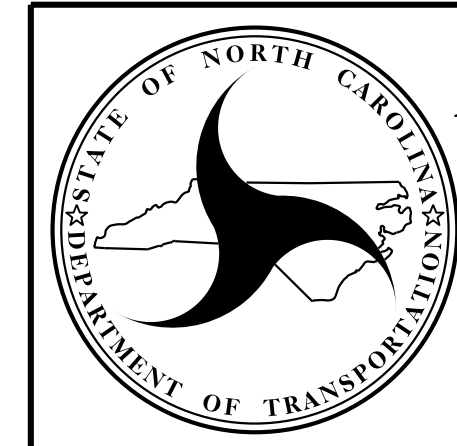

NORTH CAROLINA
DEPARTMENT OF TRANSPORTATION
DIVISION OF HIGHWAYS

GEOTECHNICAL
ENGINEERING UNIT

WALL NOTES AND DETAILS

| REVISIONS | | | | | |
|-----------|----|------|-----|----|------|
| NO. | BY | DATE | NO. | BY | DATE |
| 1 | | | 3 | | |
| 2 | | | 4 | | |

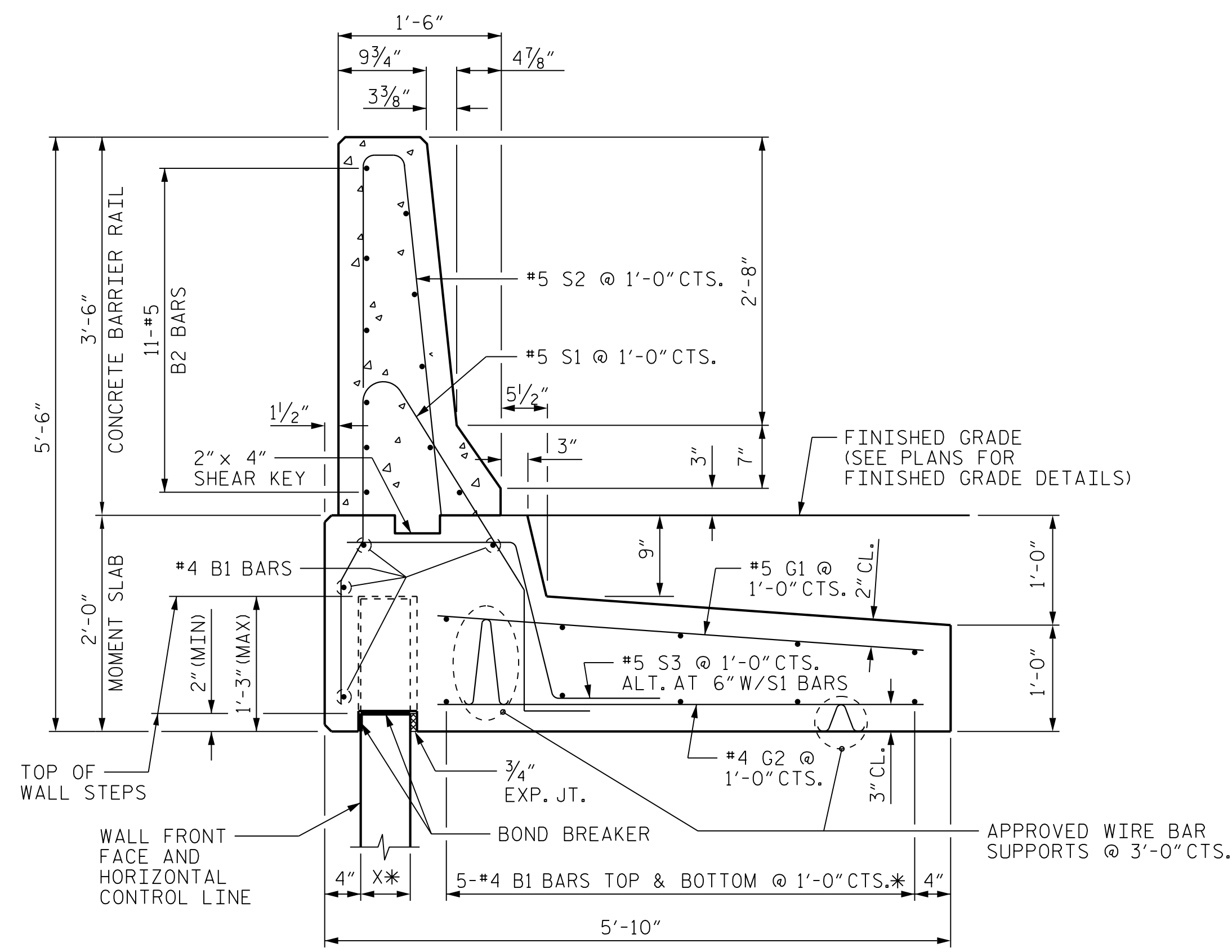

CONCRETE BARRIER RAIL WITH MOMENT SLAB

*MODIFY DIMENSIONS AS NEEDED TO ACCOMODATE PILES AND PANELS AND SUBMIT FOR APPROVAL

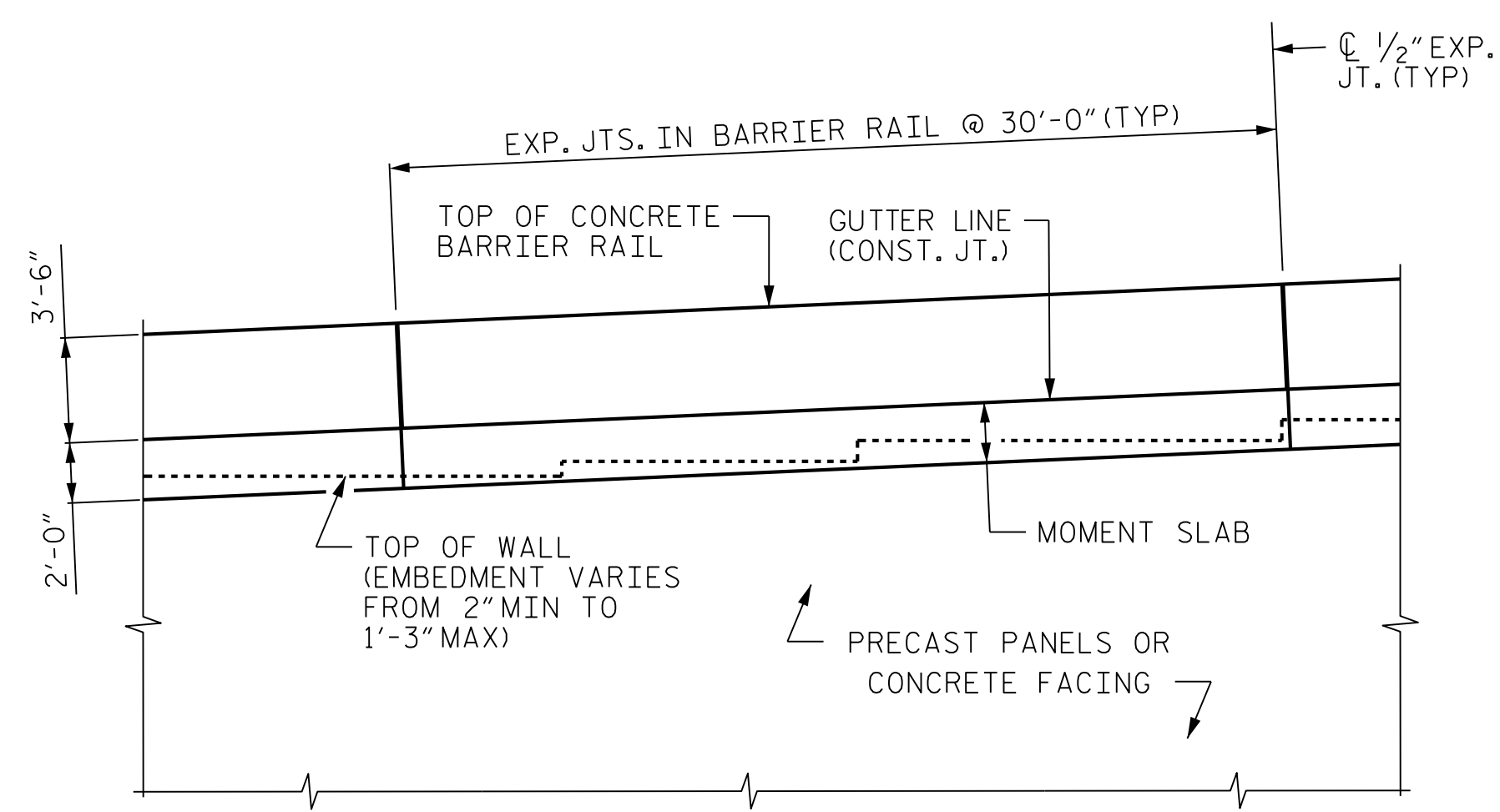

CONCRETE BARRIER RAIL WITH MOMENT SLAB - PARTIAL ELEVATION

NOTES:

FOR CONCRETE BARRIER RAIL WITH MOMENT SLAB, SEE CONCRETE BARRIER RAIL WITH MOMENT SLAB PROVISION.

CONCRETE BARRIER RAIL WITH MOMENT SLAB SHALL BE A MINIMUM OF 15' IN LENGTH.

EXPANSION JOINTS SHALL BE PLACED IN THE BARRIER RAIL AND MOMENT SLAB AT A MAXIMUM SPACING OF 30'.

GROOVED CONTRACTION JOINTS, 1/2" IN DEPTH, SHALL BE TOOLED IN ALL EXPOSED SURFACES OF THE BARRIER RAIL AND IN ACCORDANCE WITH ARTICLE 825-10(B) OF THE STANDARD SPECIFICATIONS. A CONTRACTION JOINT SHALL BE LOCATED AT EACH THIRD POINT BETWEEN BARRIER RAIL EXPANSION JOINTS. ONLY ONE CONTRACTION JOINT IS REQUIRED AT MID-POINT OF BARRIER RAIL SEGMENTS LESS THAN 20' IN LENGTH.

THE BARRIER RAIL SHALL NOT BE CAST UNTIL THE MOMENT SLAB HAS ATTAINED AN AGE OF THREE CURING DAYS OR A MINIMUM COMPRESSIVE STRENGTH OF 2,000 PSI. IN ADDITION, NO FILL MATERIAL, ASPHALT, OR CONSTRUCTION EQUIPMENT IS ALLOWED ON THE MOMENT SLAB PRIOR TO SATISFYING THE MINIMUM CONCRETE CURING AND STRENGTH REQUIREMENTS.

ALL REINFORCING STEEL IN THE BARRIER RAIL SHALL BE EPOXY COATED.

IF EXISTING OR FUTURE OBSTRUCTIONS SUCH AS FOUNDATIONS, BARRIERS, PIPES, INLETS OR UTILITIES WILL INTERFERE WITH CONCRETE BARRIER RAIL WITH MOMENT SLAB OR CONCRETE FACING FOR RETAINING WALL WILL BE THICKER THAN 8", CONCRETE BARRIER RAIL WITH MOMENT SLAB DETAILS SHALL BE REVISED AND SUBMITTED FOR APPROVAL.

CONCRETE BARRIER RAIL WITH MOMENT SLAB
PAY LENGTH = 650 LIN FT

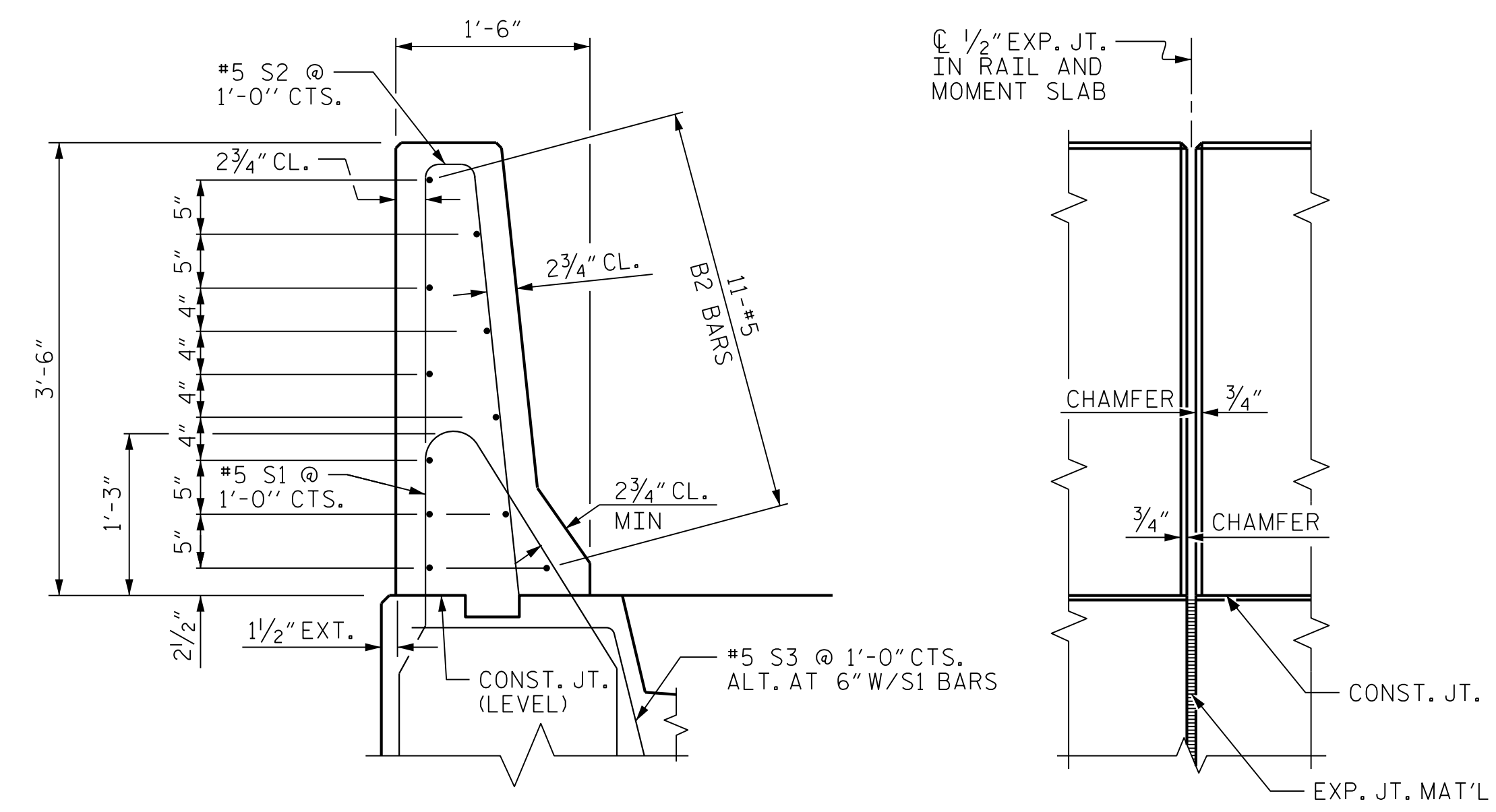

BARRIER RAIL DETAILS

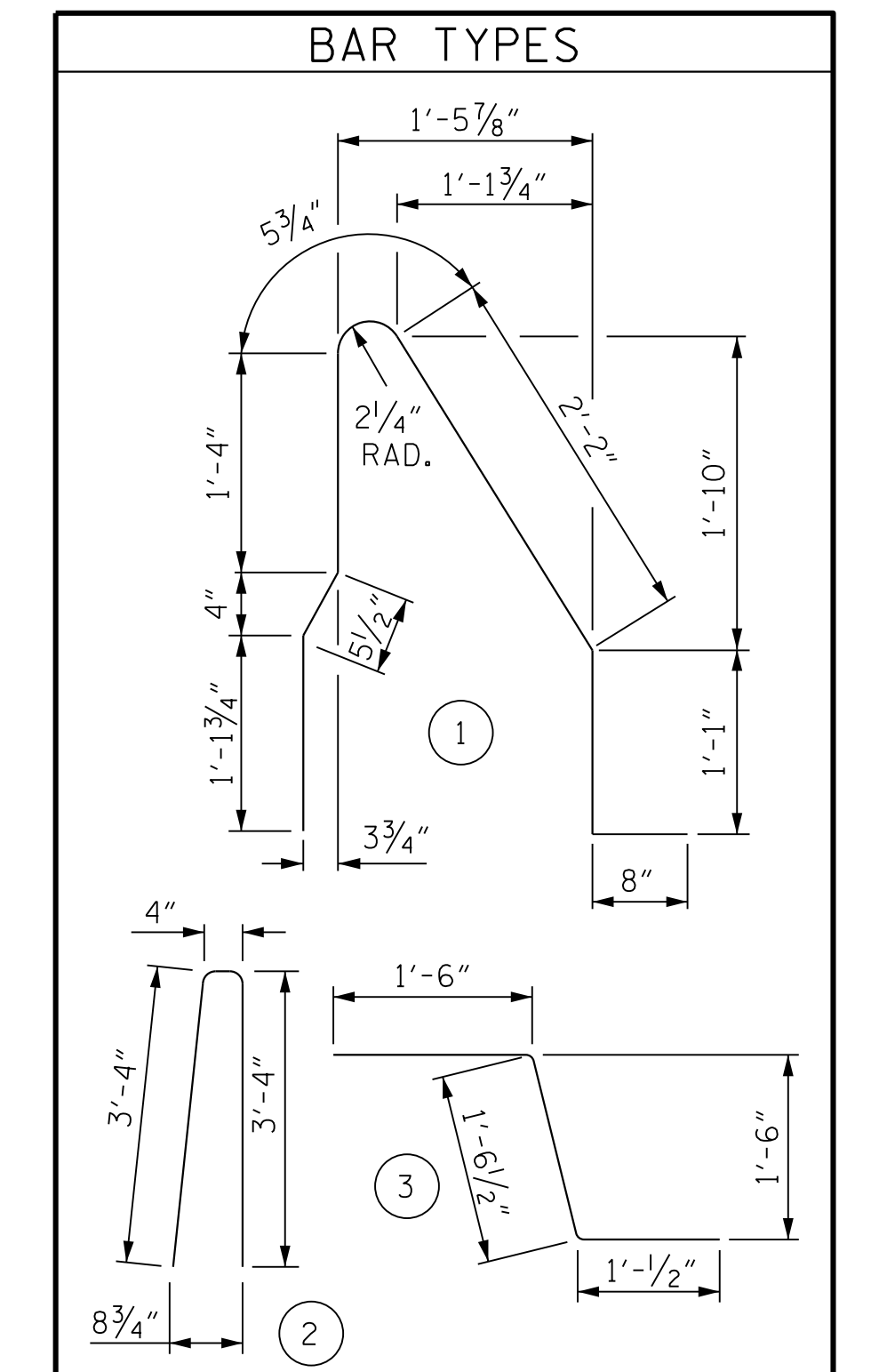

ALL BAR DIMENSIONS ARE OUT TO OUT

BILL OF MATERIAL
FOR ONE 30'-0" SECTION OF CONCRETE BARRIER RAIL WITH MOMENT SLAB

| BAR | NO. | SIZE | TYPE | LENGTH | WEIGHT |
|--|-----|------|------|--------|-----------|
| B1 | 14 | #4 | STR | 29'-7" | 277 |
| *B2 | 11 | #5 | STR | 29'-7" | 339 |
| G1 | 31 | #5 | STR | 4'-4" | 140 |
| G2 | 31 | #4 | STR | 4'-4" | 90 |
| *S1 | 31 | #5 | 1 | 7'-3" | 234 |
| *S2 | 31 | #5 | 2 | 7'-0" | 226 |
| S3 | 30 | #5 | 3 | 4'-1" | 128 |
| REINFORCING STEEL | | | | | 635 LB |
| *EPOXY COATED REINFORCING STEEL | | | | | 799 LB |
| CLASS AA CONCRETE BARRIER RAIL | | | | | 4.1 CY |
| CLASS A CONCRETE MOMENT SLAB | | | | | 9.1 CY |
| CONCRETE BARRIER RAIL WITH MOMENT SLAB | | | | | 30 LIN FT |

| | | | |
|---|--|--|--|
| PROJECT REFERENCE NO. R-4753 | | SHEET NO. W-9 | |
| GEOTECHNICAL ENGINEER  Designed by Scott Webb 9/13/2016 | | ENGINEER SIGNATURE _____ DATE _____ | |

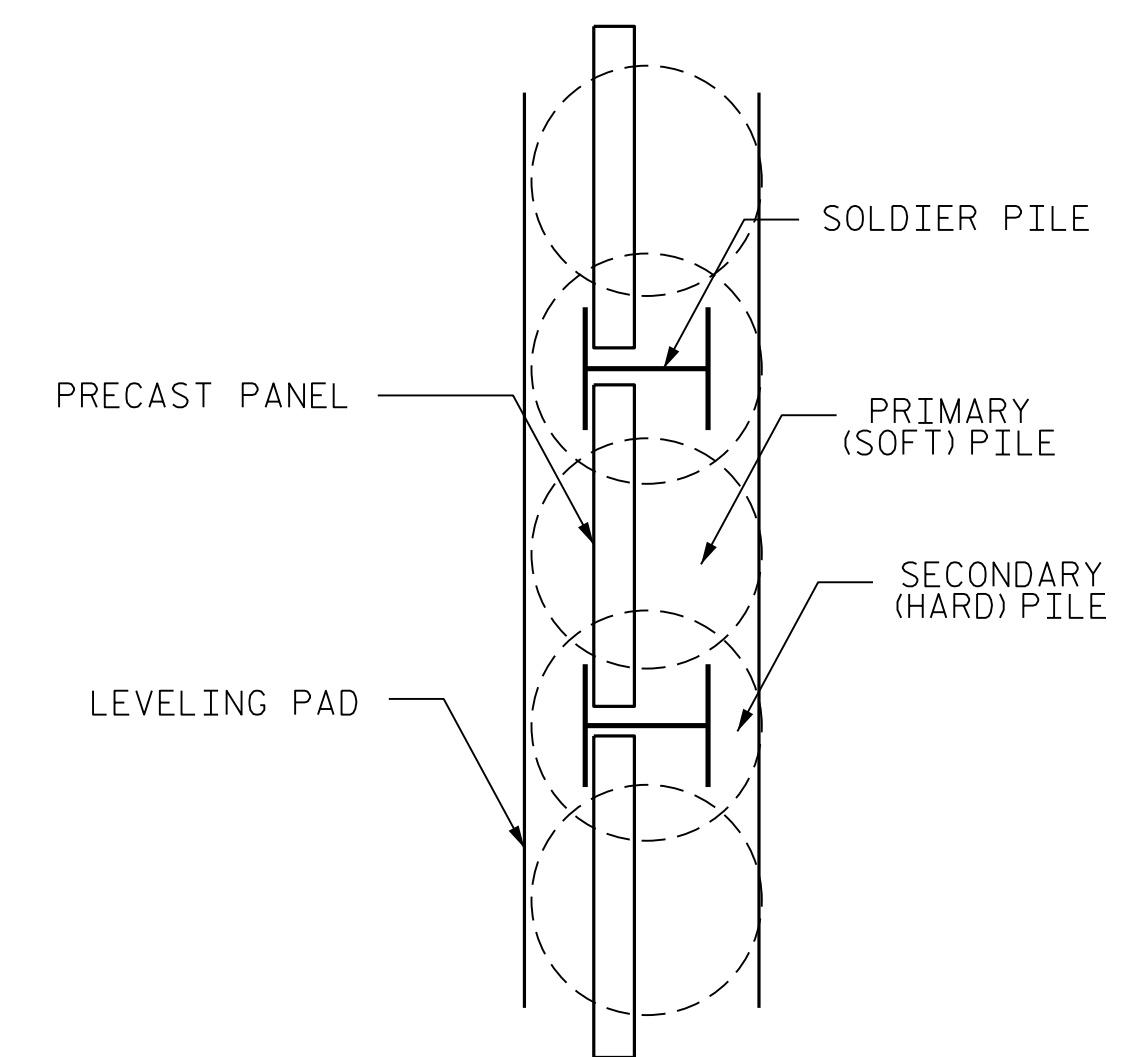
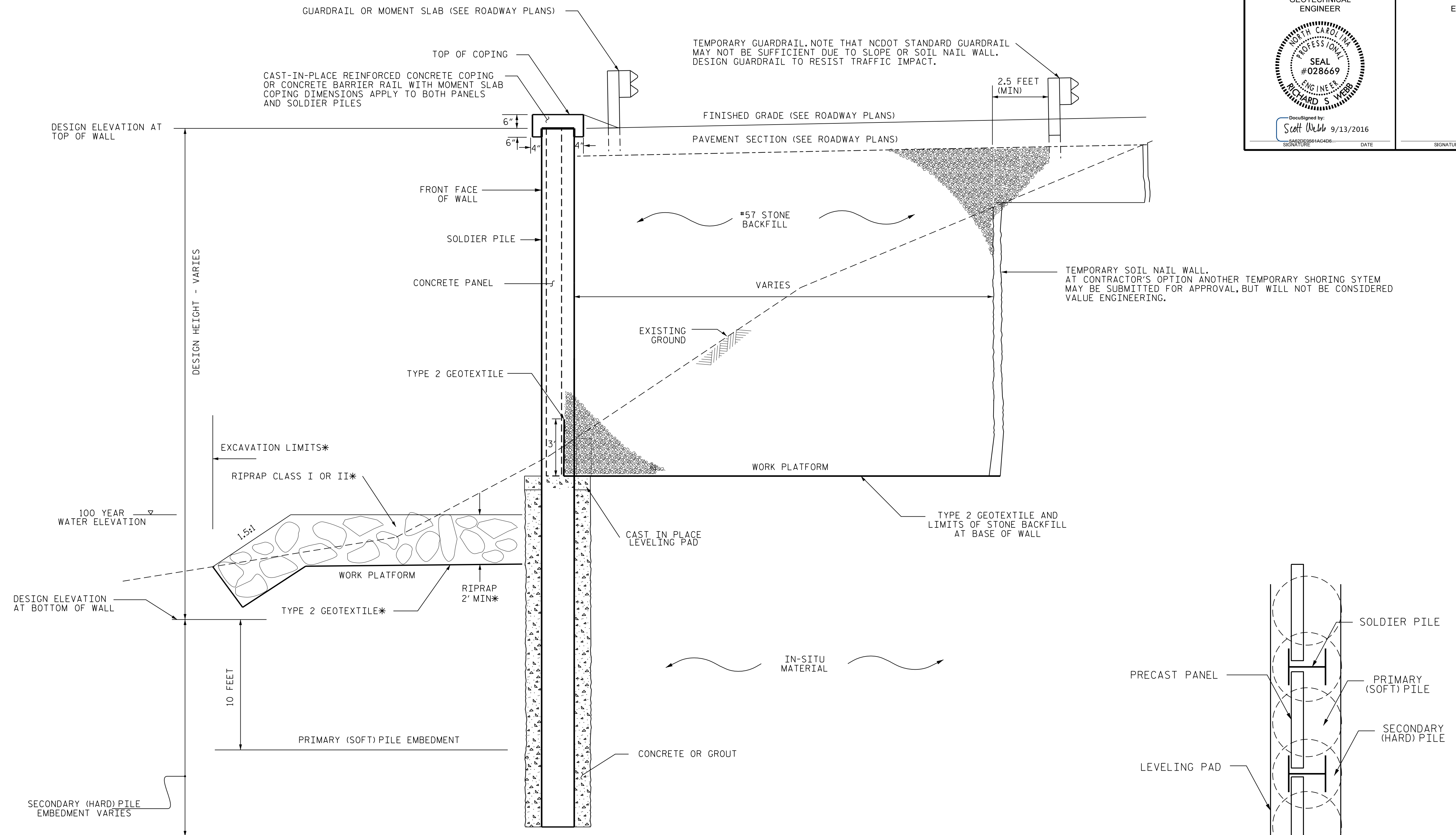

CANTILEVERED PANEL WALL WITH SECANT PILES- TYPICAL SECTION

NOT TO SCALE
 WORK PLATFORMS AND TEMPORARY SOIL NAIL WALL MAY BE OMITTED WHERE NOT NEEDED
 *ONLY IF CONTRACTOR EXCAVATES BELOW 100 YEAR WATER ELEVATION FOR WORK PLATFORM OUTSIDE WALL

| | |
|----------------------|----------------|
| PREPARED BY: RSW | DATE: 9/8/2016 |
| REVIEWED BY: MAM/SCC | DATE: 9/8/2016 |

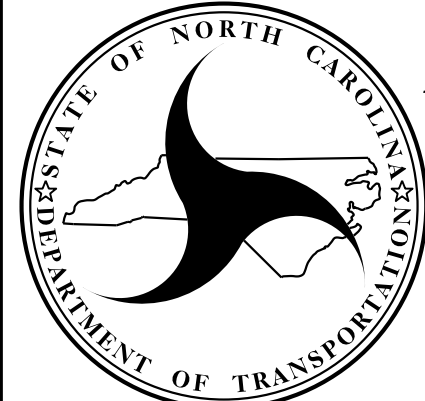

NORTH CAROLINA
DEPARTMENT OF TRANSPORTATION
DIVISION OF HIGHWAYS

GEOTECHNICAL
ENGINEERING UNIT

| CANTILEVERED PANEL WALL WITH SECANT PILES | | | | | |
|---|----|------|-----|----|------|
| REVISIONS | | | | | |
| NO. | BY | DATE | NO. | BY | DATE |
| 1 | | | 3 | | |
| 2 | | | 4 | | |

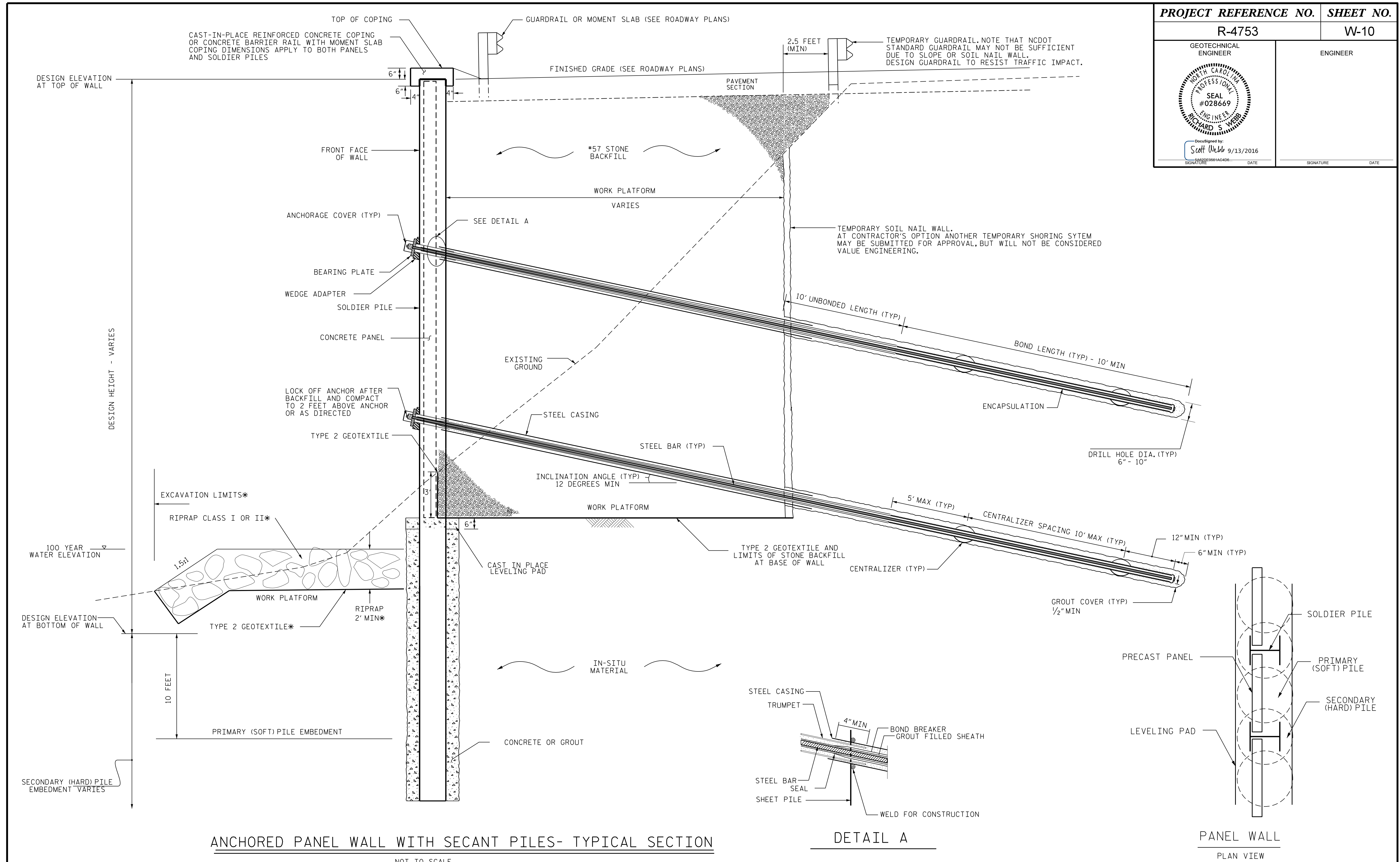

ANCHORED PANEL WALL WITH SECANT PILES- TYPICAL SECTION

DETAIL A

PANEL WALL PLAN VIEW

NOT TO SCALE
 WORK PLATFORMS AND TEMPORARY SOIL NAIL WALL MAY BE OMITTED WHERE NOT NEEDED
 *ONLY IF CONTRACTOR EXCAVATES BELOW 100 YEAR WATER ELEVATION FOR WORK PLATFORM OUTSIDE WALL

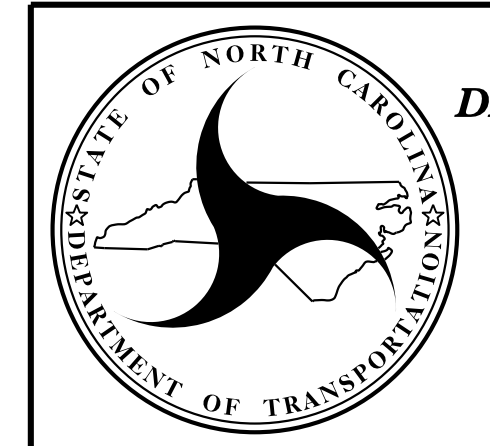

**NORTH CAROLINA
 DEPARTMENT OF TRANSPORTATION
 DIVISION OF HIGHWAYS**

**GEOTECHNICAL
 ENGINEERING UNIT**

**ANCHORED
 PANEL WALL
 WITH SECANT PILES**

| REVISIONS | | | | | |
|-----------|----|------|-----|----|------|
| NO. | BY | DATE | NO. | BY | DATE |
| 1 | | | 3 | | |
| 2 | | | 4 | | |

| | |
|----------------------|----------------|
| PREPARED BY: RSW | DATE: 9/8/2016 |
| REVIEWED BY: MAM/SCC | DATE: 9/8/2016 |