

PROJECT REFERENCE NO. B-5343		SHEET NO. EC-5/CONST.4	
RW SHEET NO.			
ROADWAY DESIGN ENGINEER		HYDRAULICS ENGINEER	

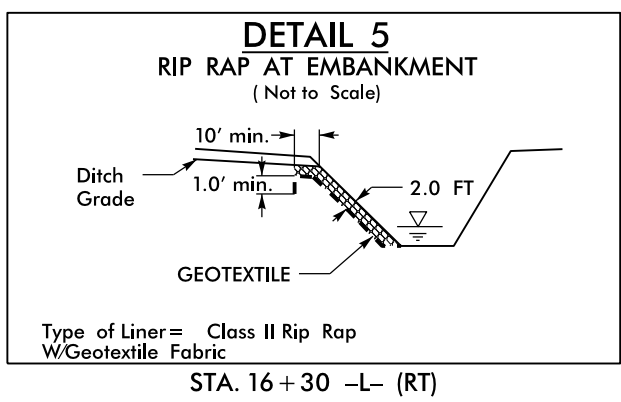
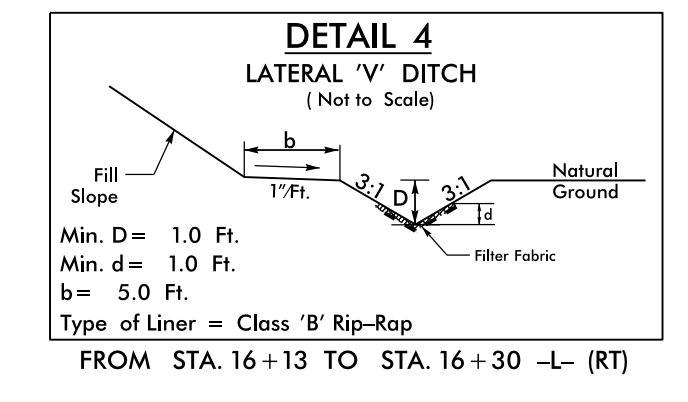
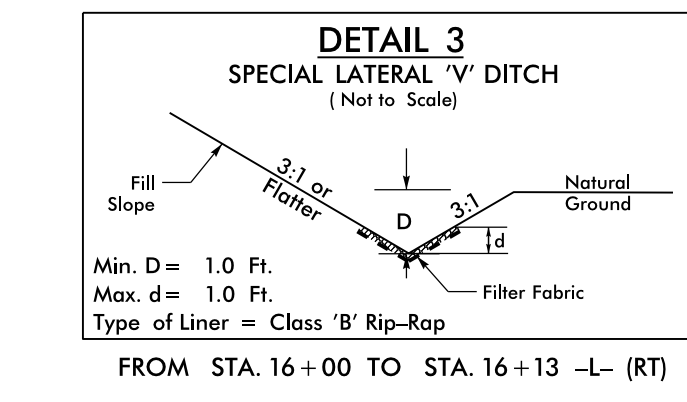
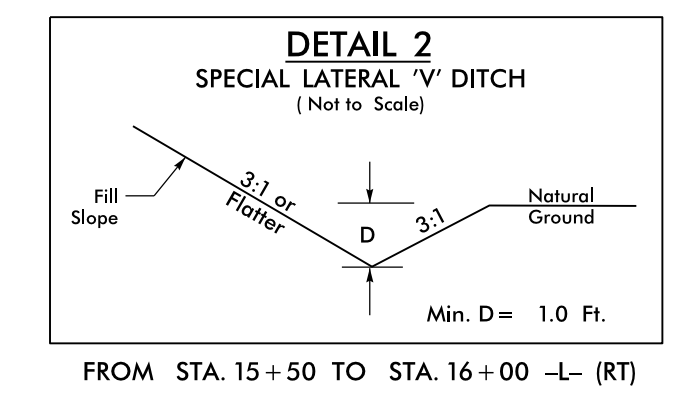
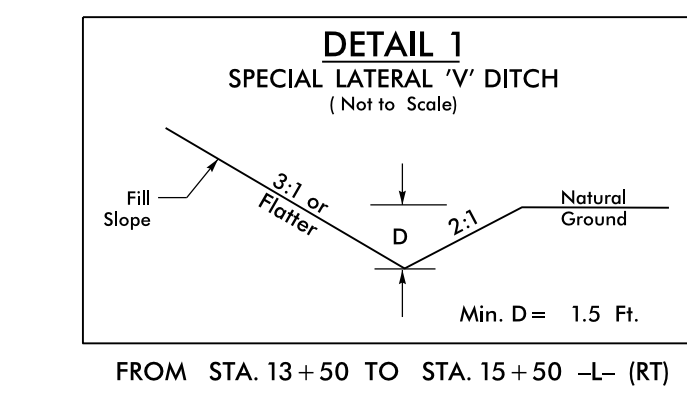
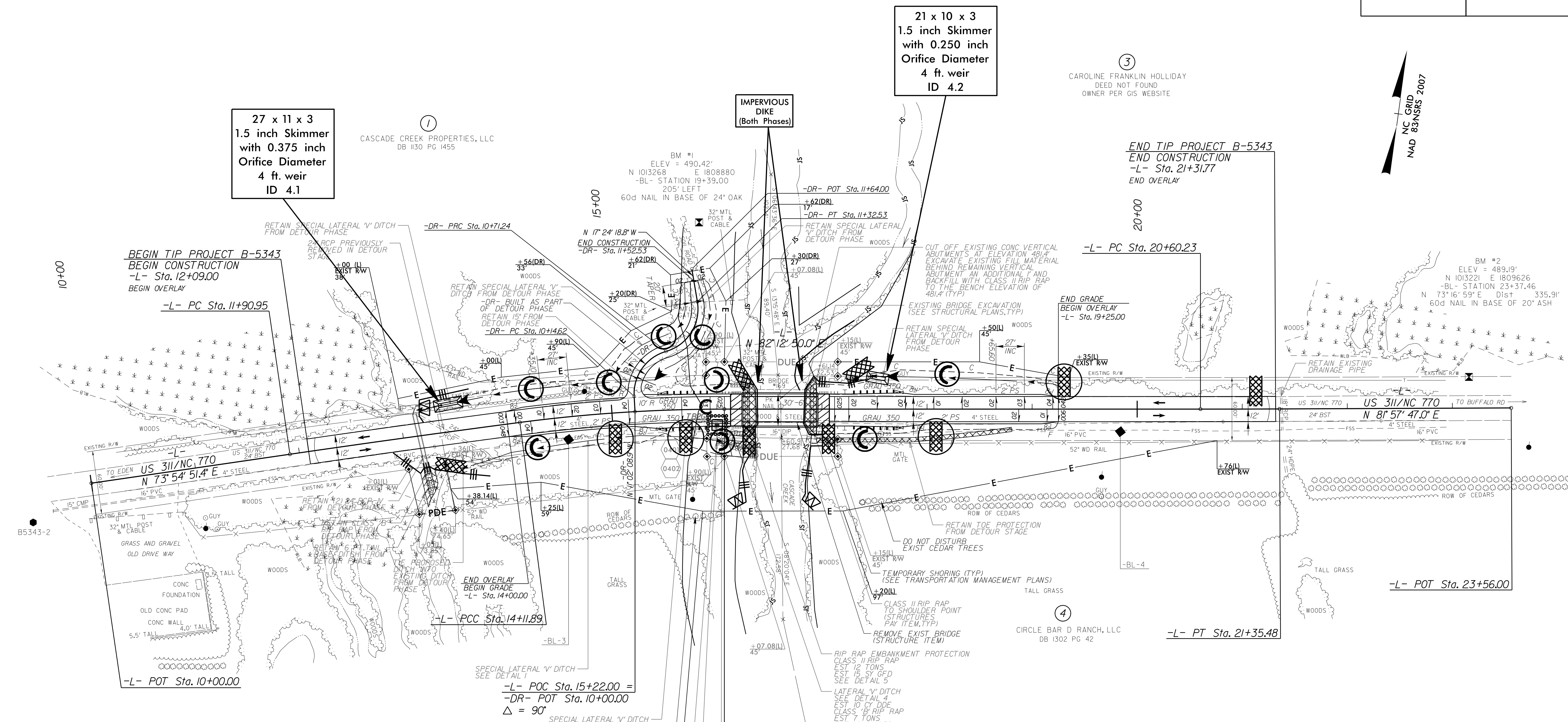

NOTE: UTILIZE TEMPORARY SEDIMENT BASIN OR SPECIAL STILLING BASIN(S) AS STILLING BASIN WHERE APPLICABLE.

SDATES