

NOTES

APPROACH SLAB SHALL NOT BE CONSTRUCTED PRIOR TO COMPLETION OF THE BRIDGE DECK.

FOR REINFORCED BRIDGE APPROACH FILL FABRIC WALL INCLUDING GEOTEXTILE, IMPERMEABLE GEOMEMBRANE, 4" Ø DRAINAGE PIPE, #78M STONE, WELDED WIRE FORM, AND SELECT MATERIAL, SEE ROADWAY PLANS.

AREA BETWEEN THE WINGWALL AND APPROACH SLAB SHALL BE GRADED TO DRAIN THE WATER AWAY FROM THE FILL FACE OF THE BRIDGE AND SHALL BE PAVED. SEE ROADWAY PLANS.

THE JOINT OPENING AT THE APPROACH SLAB/DECK INTERFACE SHALL BE SAWED NO MORE THAN 12 HOURS AFTER THE APPROACH SLAB IS CAST. THE JOINT SHALL BE CLEANED OF ALL DEBRIS BEFORE THE SEALANT IS APPLIED. THE JOINT SEALER MATERIAL SHALL CONFORM TO THE REQUIREMENTS OF SECTION 1028-3 OF THE STANDARD SPECIFICATIONS.

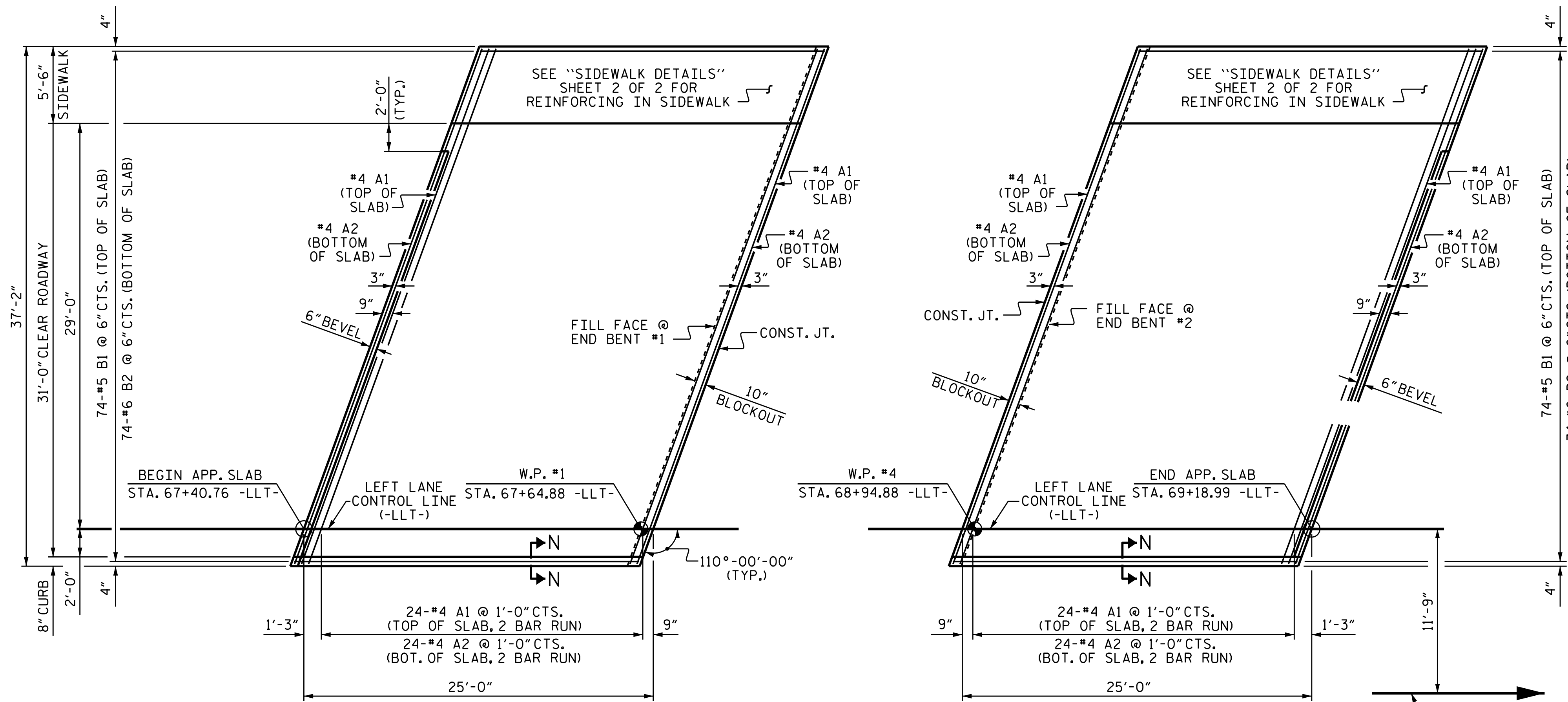

PLAN @ END BENT #1

PLAN @ END BENT #2

DIMENSIONS SHOWN ARE TYPICAL FOR BOTH APPROACH SLABS

BAR TYPE					
BILL OF MATERIAL FOR ONE APPROACH SLAB (2 REQ'D)					
BAR	NO.	SIZE	TYPE	LENGTH	WEIGHT
* A1	52	#4	STR	20'-8"	718
A2	52	#4	STR	20'-6"	712
* B1	74	#5	STR	24'-1"	1859
B2	74	#6	STR	24'-7"	2732
* B3	5	#4	STR	24'-7"	82
* G1	25	#4	STR	5'-3"	88
* U1	8	#4	1	3'-4"	18
REINFORCING STEEL				LBS.	3,444
* EPOXY COATED REINFORCING STEEL				LBS.	2,765
CLASS AA CONCRETE					
APPROACH SLAB & CURB =				C. Y.	40.1
SIDEWALK =				C. Y.	3.1
TOTAL =				C. Y.	43.2

SPlice LENGTHS		
BAR SIZE	EPOXY COATED	UNCOATED
#4	2'-0"	1'-9"
#5	2'-6"	2'-2"
#6	3'-10"	2'-7"

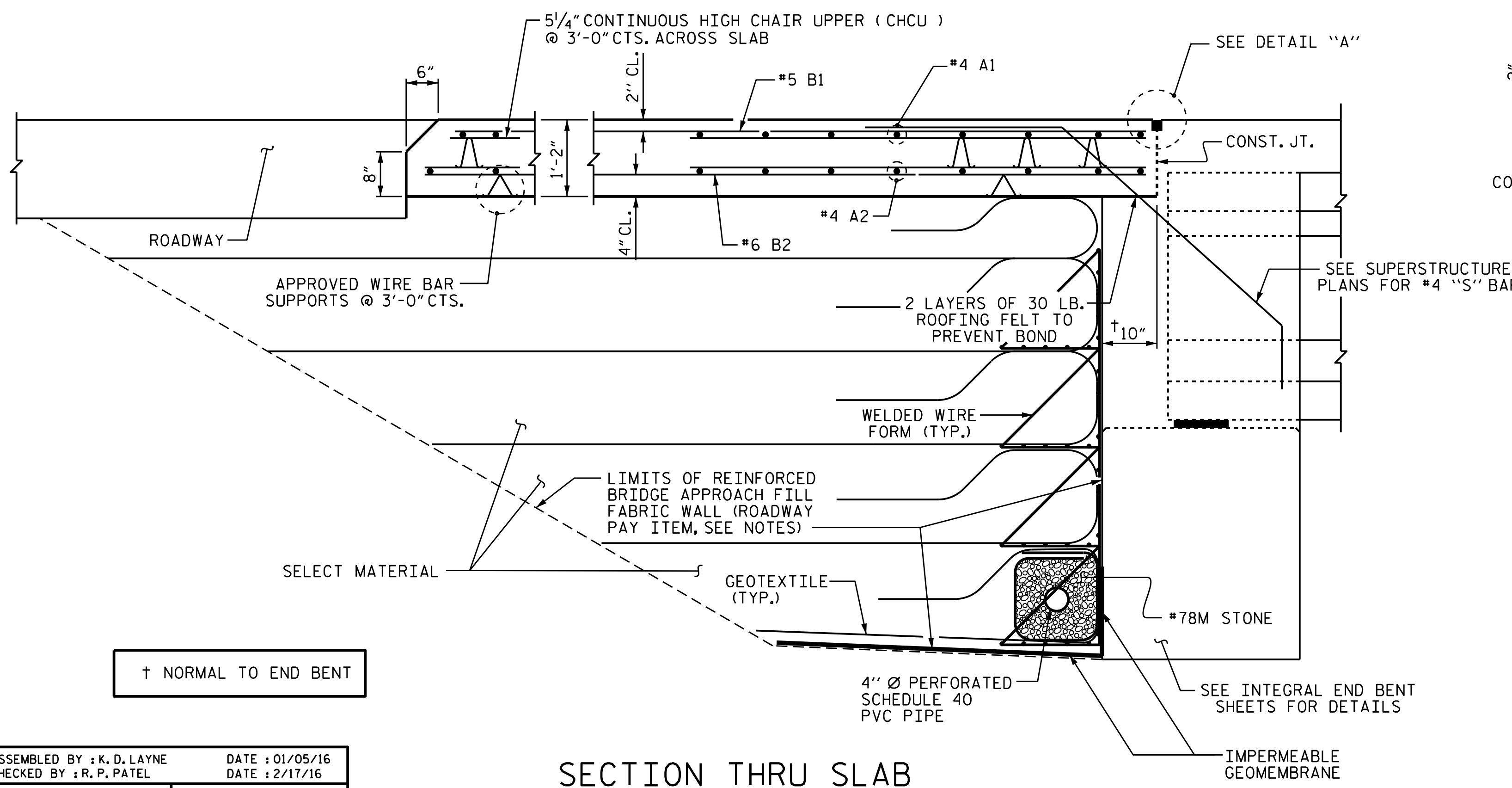

SECTION THRU SLAB

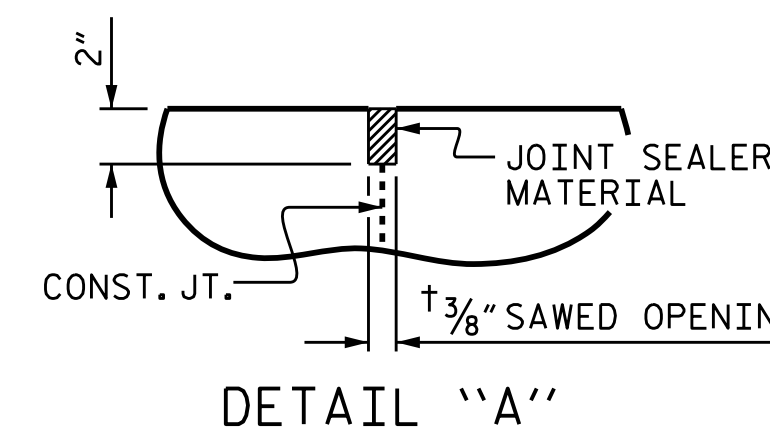

DETAIL "A"

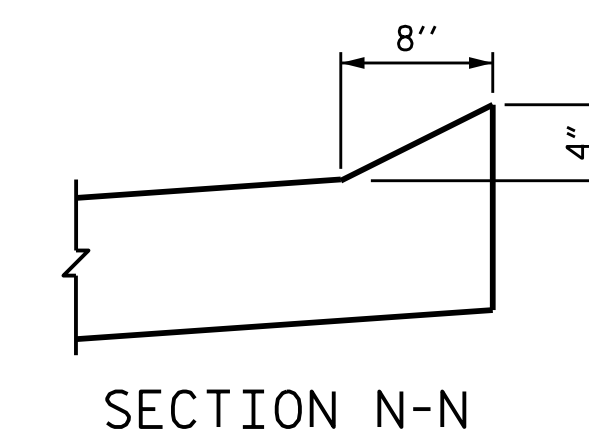

SECTION N-N

END OF CURB WITHOUT SHOULDER BERM GUTTER

PROJECT NO. U-3440
CABARRUS COUNTY
 STATION: 68+25.60 -L-

SHEET 1 OF 2

STATE OF NORTH CAROLINA
 DEPARTMENT OF TRANSPORTATION
 RALEIGH
 STANDARD
 BRIDGE APPROACH SLAB
 FOR INTEGRAL ABUTMENT
 (LEFT LANE)

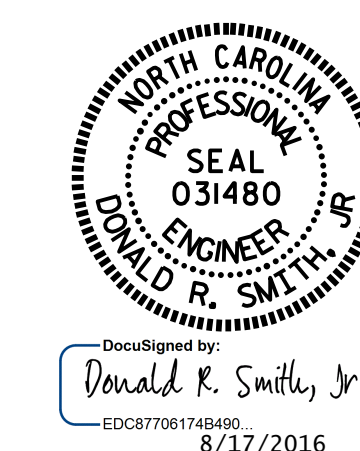

DOCUMENT NOT CONSIDERED FINAL UNLESS ALL SIGNATURES COMPLETED

REVISIONS						SHEET NO.
NO.	BY:	DATE:	NO.	BY:	DATE:	S1-36
1			3			TOTAL SHEETS 37
2			4			

ASSEMBLED BY : K. D. LAYNE	DATE : 01/05/16	
CHECKED BY : R. P. PATEL	DATE : 2/17/16	
DRAWN BY : TLA	10/05	MAA/GM
CHECKED BY : GM	5/06	MAA/GM
	REV. 10/1/11	MAA/GM
	REV. 12/21/11	MAA/GM
	REV. 6/13	MAA/GM