

NOTES

THE TOP SURFACE OF THE END BENT CAP, EXCEPT THE BEARING AREA, SHALL BE RAKED TO A DEPTH OF 1/4".

THE CONCRETE IN THE SHADED AREA OF THE WING SHALL BE POURED AFTER THE CONCRETE BARRIER RAIL IS CAST IF SLIP FORMING IS USED.

INSTALL THE 4" DIA. DRAIN PIPE THROUGH THE WING WALL AS REQUIRED FOR REINFORCED BRIDGE APPROACH FILLS. SEE ROADWAY PLANS. REINFORCING STEEL IN THE WING MAY BE SHIFTED AS NECESSARY TO CLEAR THE DRAIN PIPE.

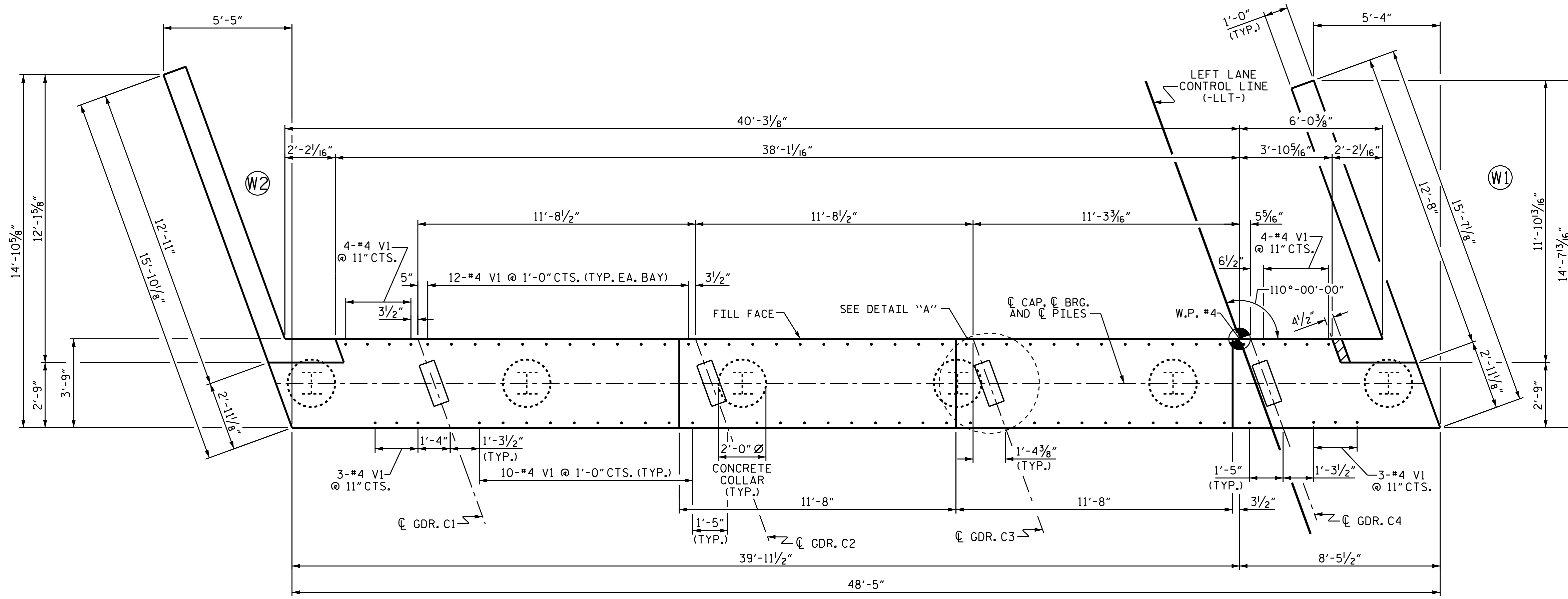

PLAN

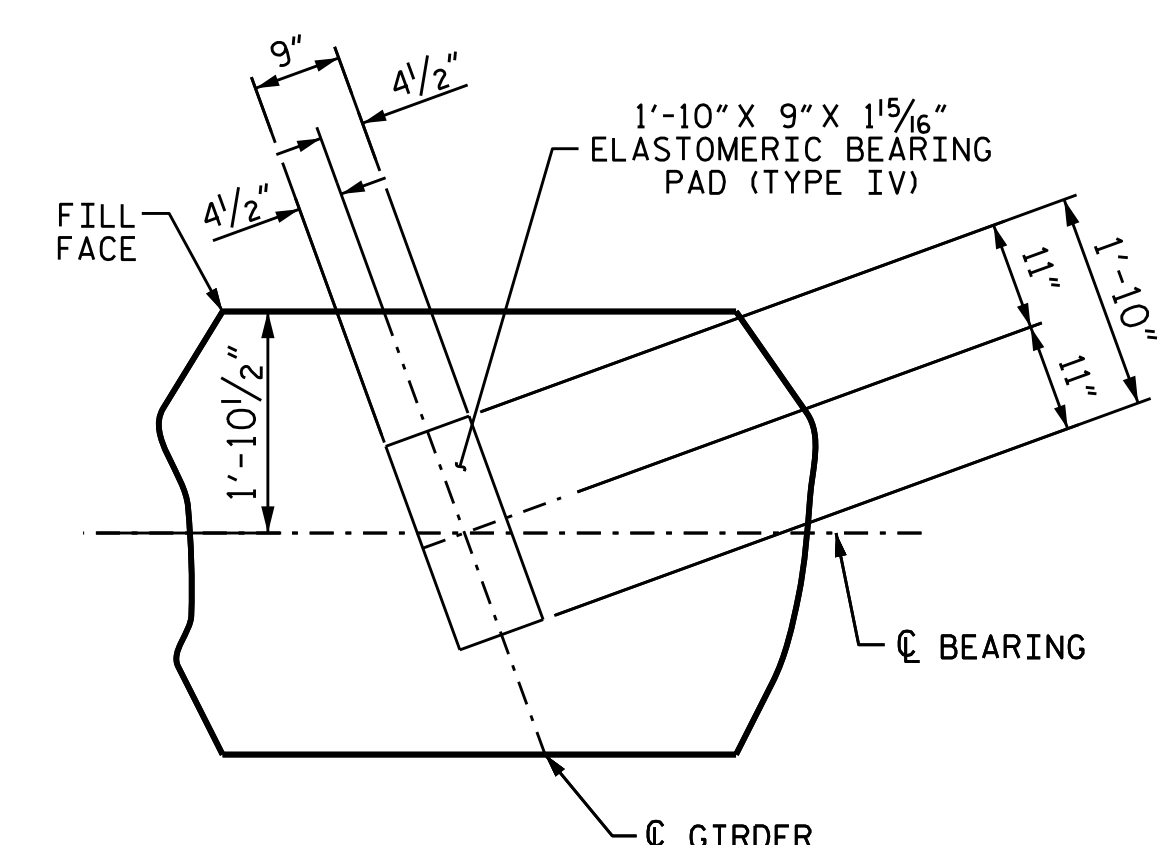

DETAIL "A"
(TYP. EACH GIRDER)

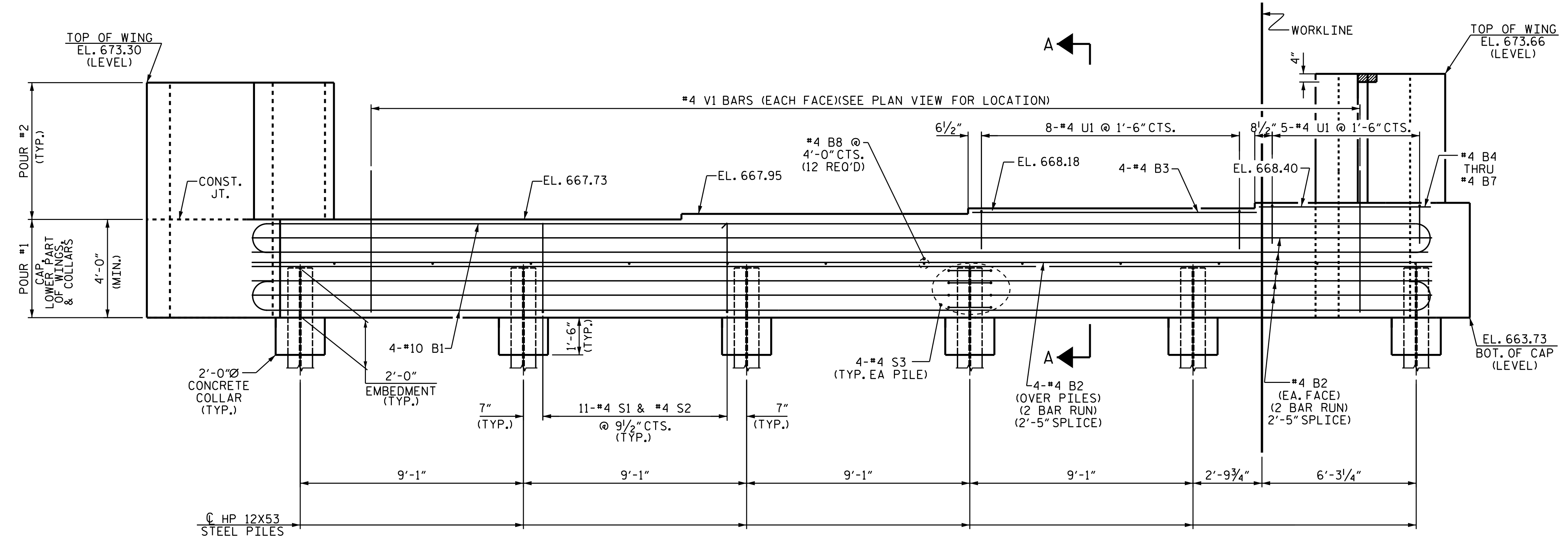

ELEVATION

PROJECT NO. U-3440
CABARRUS COUNTY
 STATION: 68+25.60 -L-

SHEET 1 OF 3

STATE OF NORTH CAROLINA
 DEPARTMENT OF TRANSPORTATION
 RALEIGH
 SUBSTRUCTURE
 END BENT 2
 (LEFT LANE)

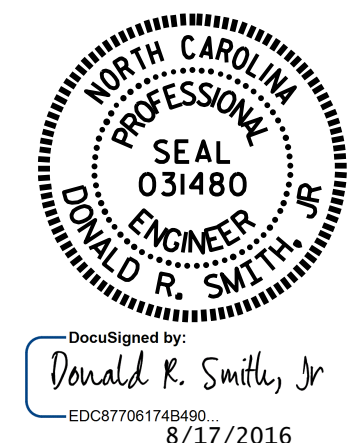

DOCUMENT NOT CONSIDERED FINAL UNLESS ALL SIGNATURES COMPLETED

REVISIONS						SHEET NO.	
NO.	BY:	DATE:	NO.	BY:	DATE:	SI-32	
1			3			TOTAL SHEETS	
2			4			37	

DRAWN BY: J.D. HAWK DATE: 4/2016
 CHECKED BY: K.D. LAYNE DATE: 4/2016
 DESIGN ENGINEER OF RECORD: T.R. PETERSON DATE: 6/20/16