

Note:
 1. Opening in pole base plate shall be equal to pole base inside diameter minus 3 1/2" but shall not be less than 8 1/2".

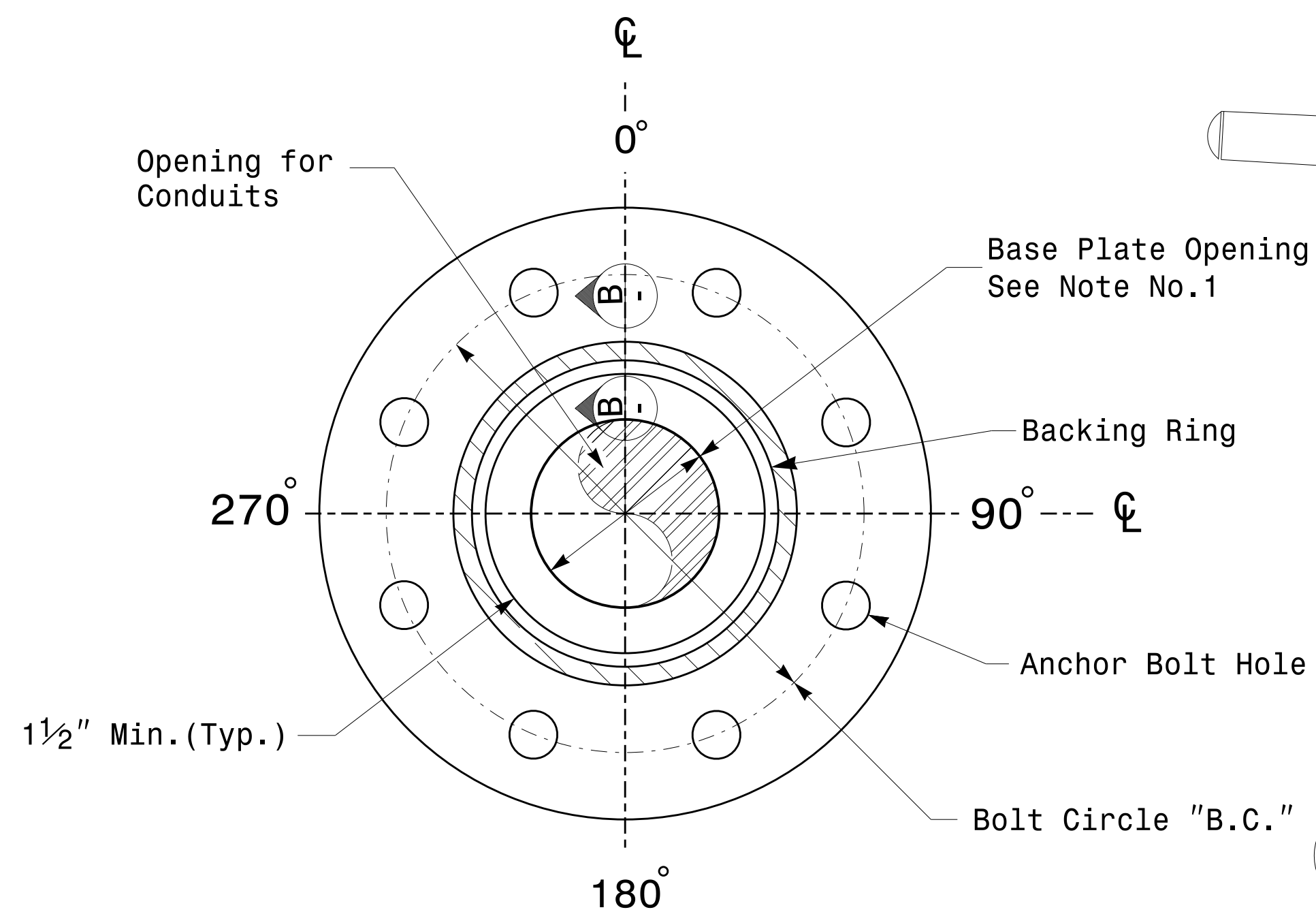

Section A-A
Pole Base Plate Details

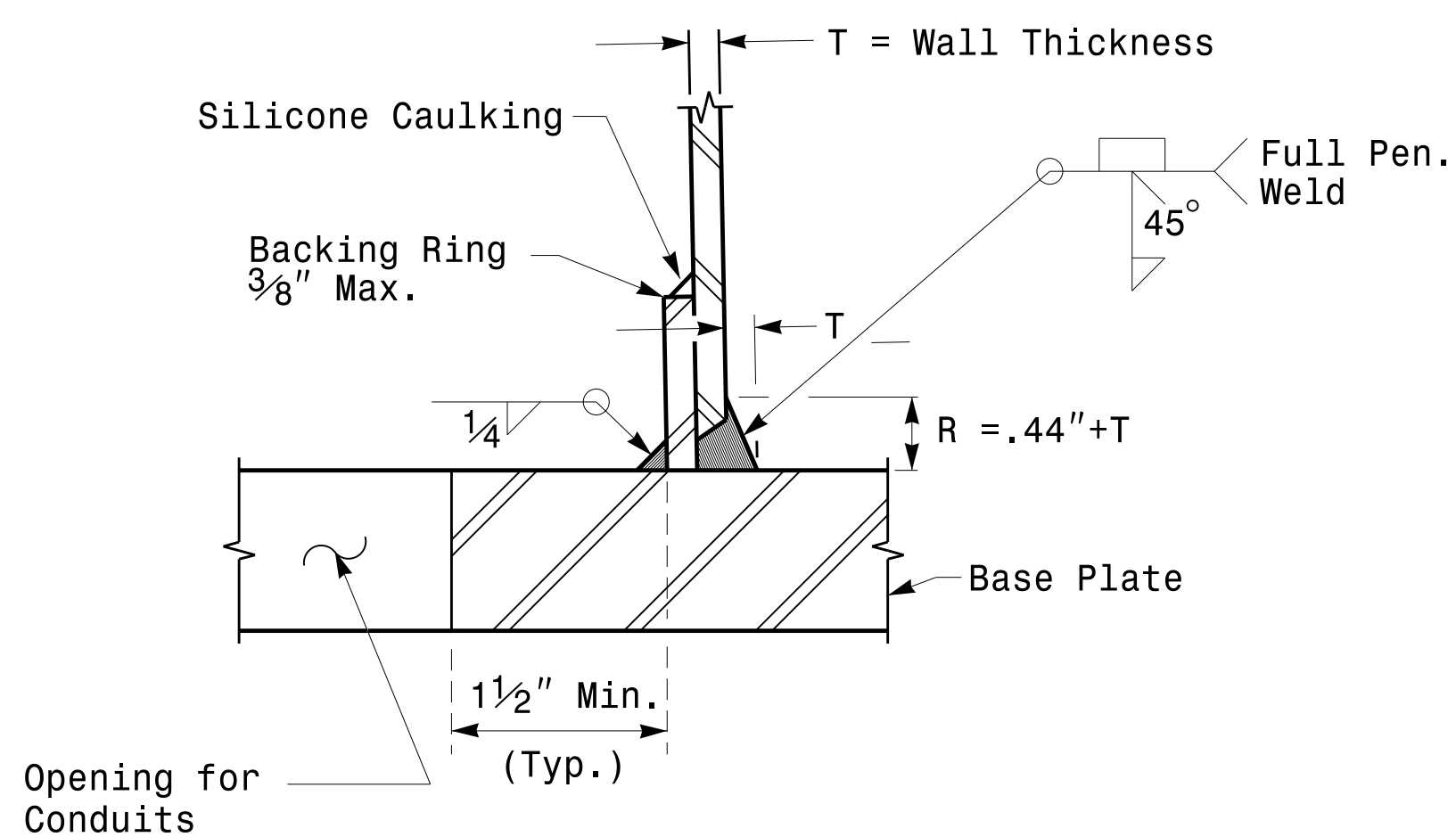

Section B-B
 (Pole Attachment to Base Plate)
Full-Penetration Groove Weld Detail

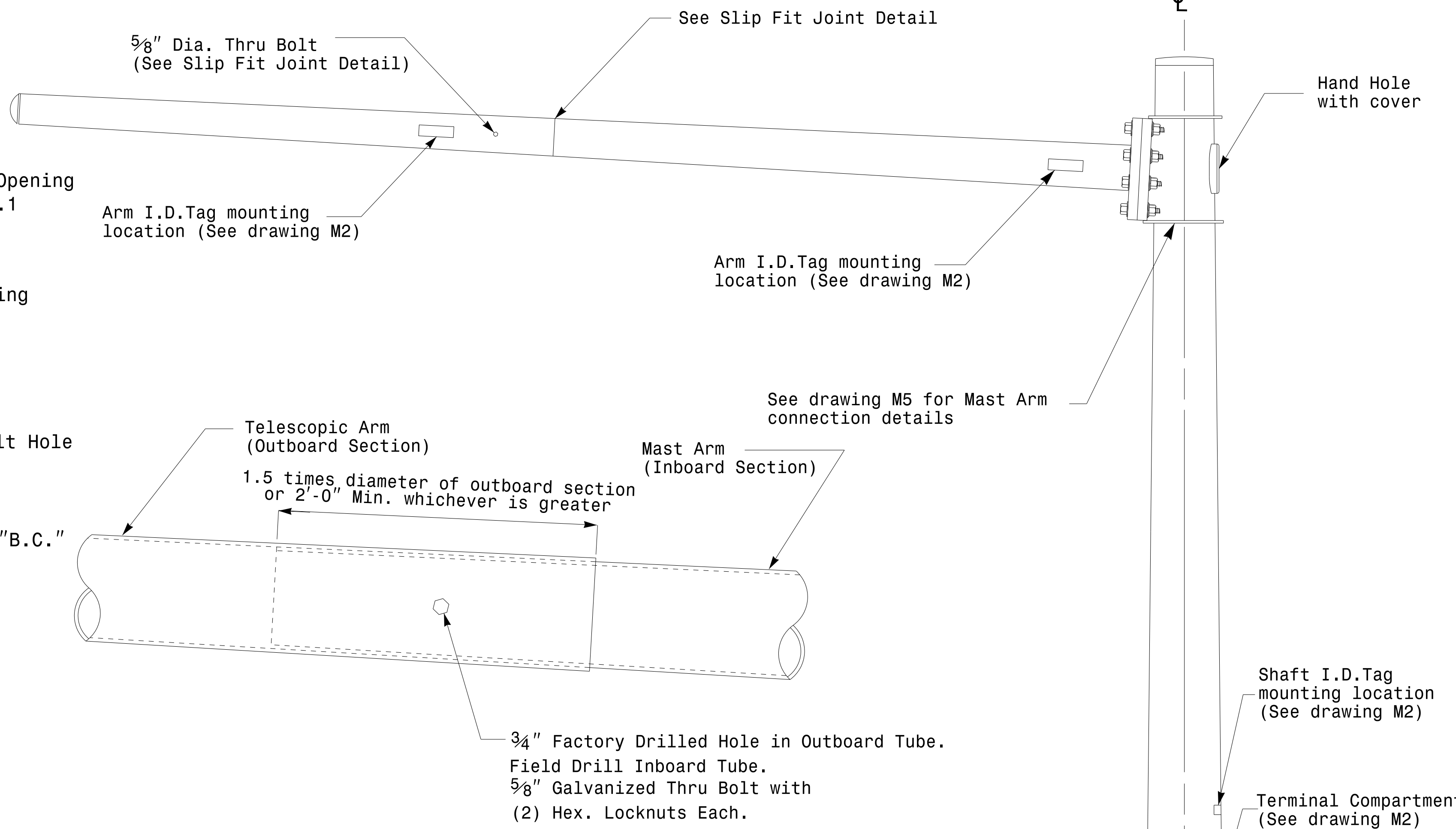

Slip Fit Joint Detail for Mast Arm

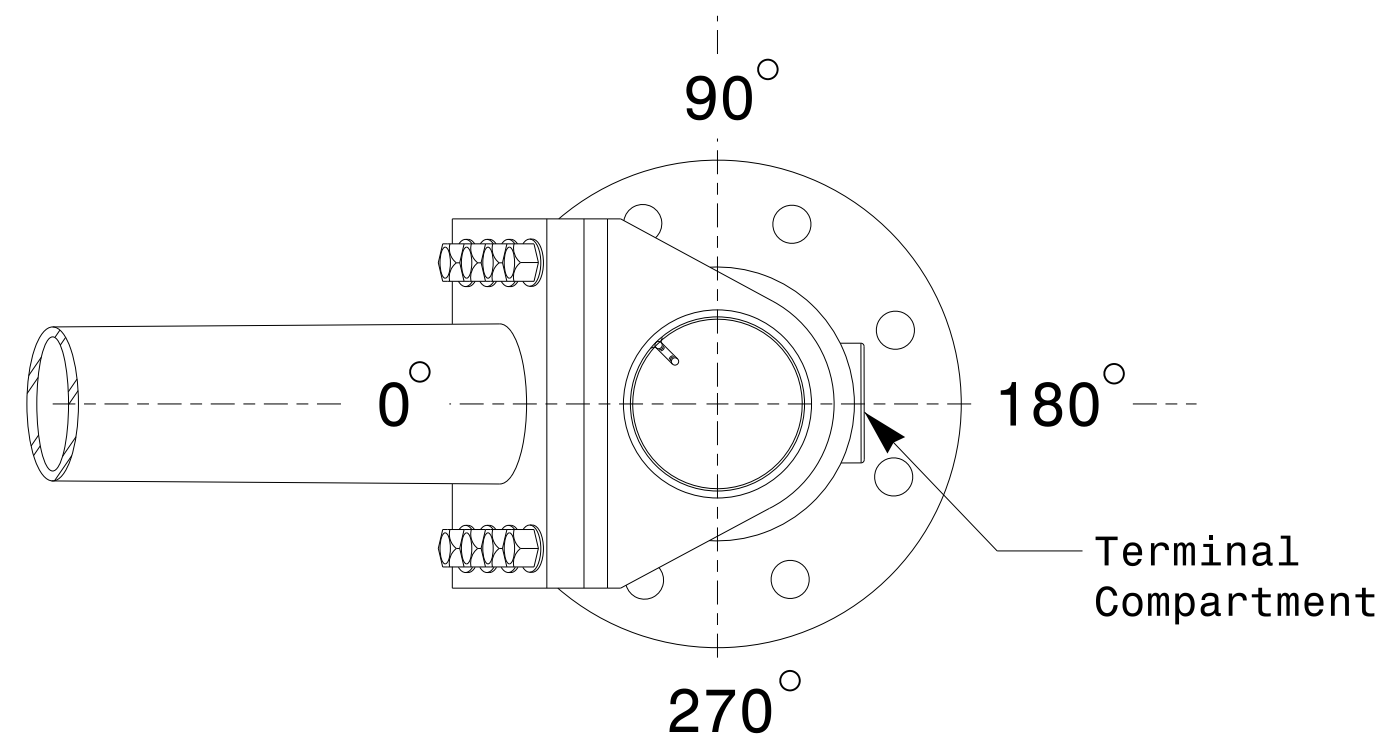

Mast Arm Radial Orientation

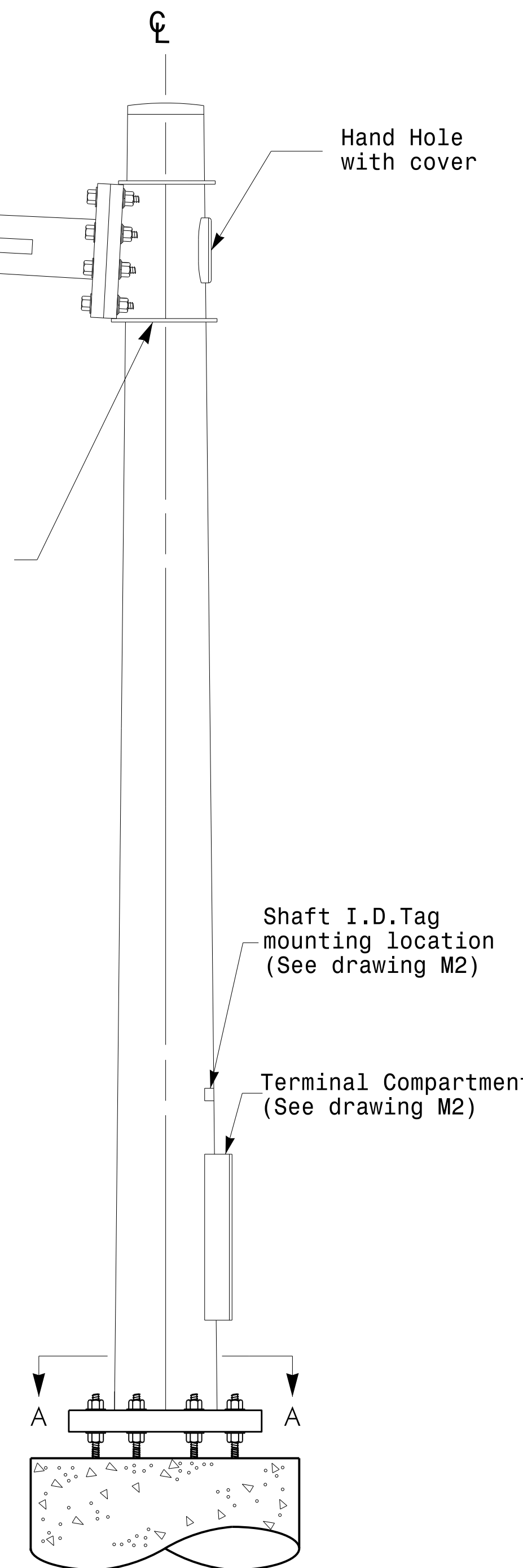

Mast Arm Pole

Fabrication Details - Mast Arm Poles

Prepared in the Offices of: 750 N. Greenfield Pkwy, Garner, NC 27529	Typical Fabrication Details For Mast Arm Poles		SEAL DocuSigned by <i>Dibesh C. Sarkar</i> 44E8E32E147E4C4...
	PLAN DATE: FEBRUARY 2016 PREPARED BY: N. BITTING	DESIGNED BY: K.C. DURIGON REVIEWED BY: D.C. SARKAR	
SCALE: 0 NA NONE			2/17/2016 DATE

17-FEB-2016 16:05
 U:\3604115\Sig.M4\Sig.M4.dgn
 Design Section Eastern Region\Sig.M4\Sig.M4.dgn
 17-FEB-2016 16:05
 U:\3604115\Sig.M4\Sig.M4.dgn