

SECTION A-A
STA. 117+50 -L-

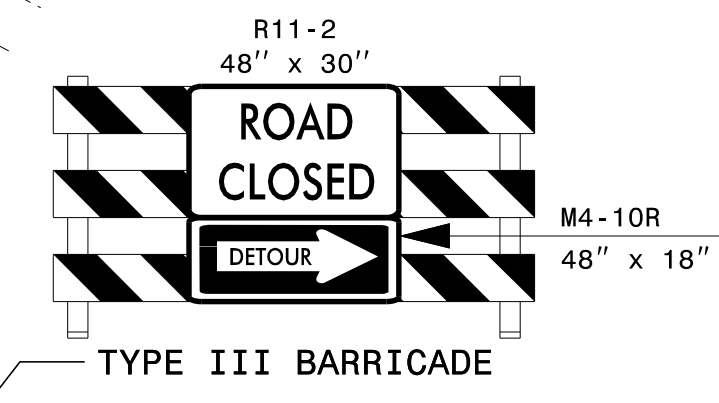

MATCHLINE -L- STA 113+25 SEE SHEET 11

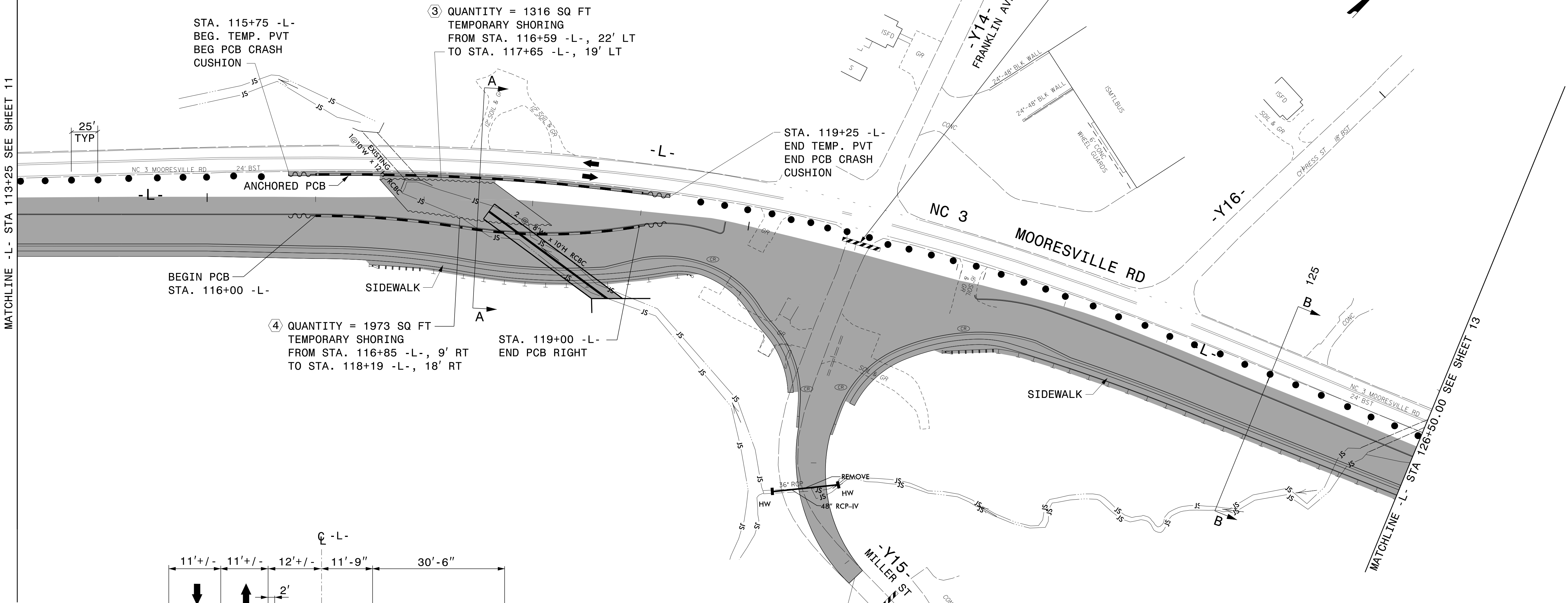

③ QUANTITY = 1316 SQ FT
TEMPORARY SHORING
FROM STA. 116+59 -L-, 22' LT
TO STA. 117+65 -L-, 19' LT

④ QUANTITY = 1973 SQ FT
TEMPORARY SHORING
FROM STA. 116+85 -L-, 9' RT
TO STA. 118+19 -L-, 18' RT

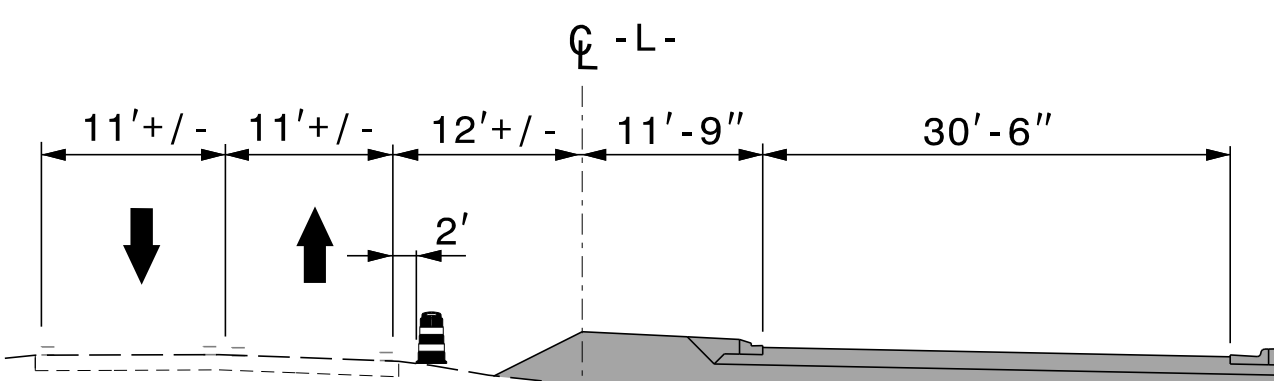

SECTION B-B
STA. 125+00 -L-

STA. 13+15.73 -Y15-
END CONST.

SEE SHEET TMP-37 FOR -Y15- DETOUR ROUTE.

APPROVED: *Stew Kite*
DATE: 8/19/2016

PROFESSIONAL SEAL
022104
JOHN S. KITE, P.E.
ENGINEER

DOCUMENT NOT CONSIDERED FINAL
UNLESS ALL SIGNATURES COMPLETED

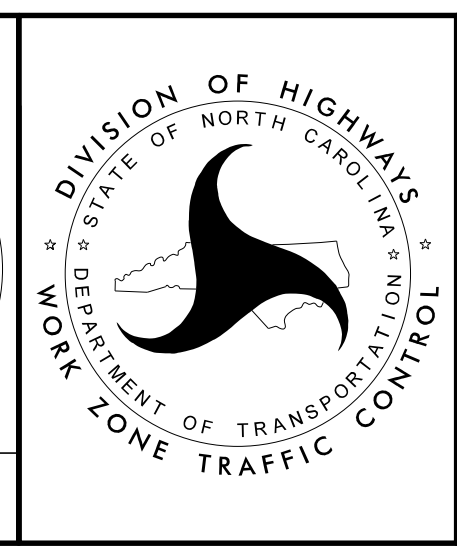

PHASE I DETAILS

8/17/2016
P:\TIP\Projects-U\3440\TrafficControl\TCP\tmp-12-phase1.dgn
User:rmgarratt