

**This electronic collection of documents is provided
for the convenience of the user
and is Not a Certified Document –**

**The documents contained herein were originally issued
and sealed by the individuals whose names and license
numbers appear on each page, on the dates appearing
with their signature on that page.**

**This file or an individual page
shall not be considered a certified document.**

T.I.P.: R-2915C

CONTRACT:

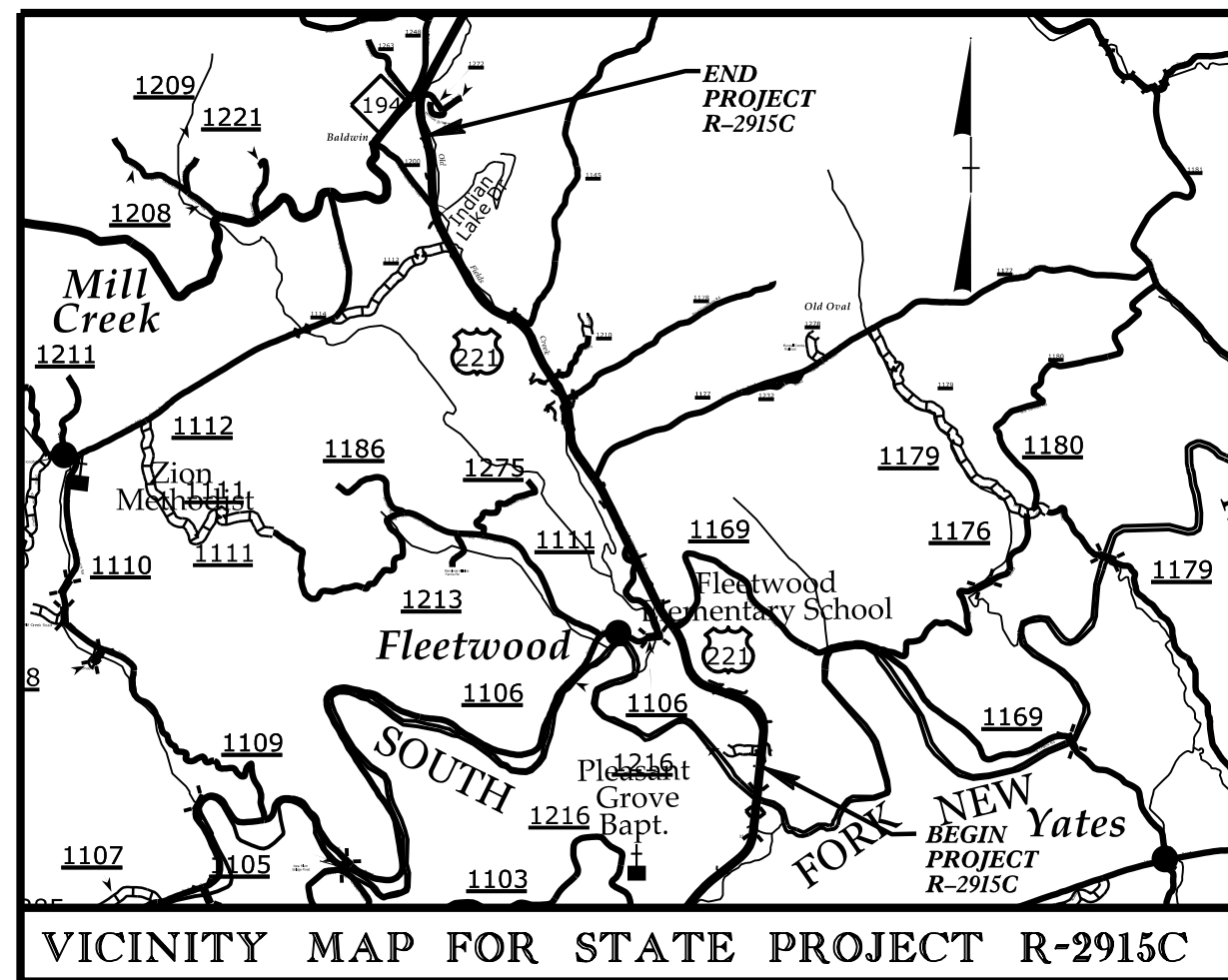

**STATE OF NORTH CAROLINA
DEPARTMENT OF TRANSPORTATION**

**PAVEMENT MARKING PLAN
ASHE COUNTY**

**LOCATION: US 221 FROM NORTH OF SOUTH FORK NEW RIVER
TO SOUTH OF NC 194.**

TIP NO. R-2915C	SHEET NO. PMP-1
APPROVED: <u>Joseph Kopaskie</u> 6/29/2016	
DOCUMENT NOT CONSIDERED FINAL UNLESS ALL SIGNATURES COMPLETED	

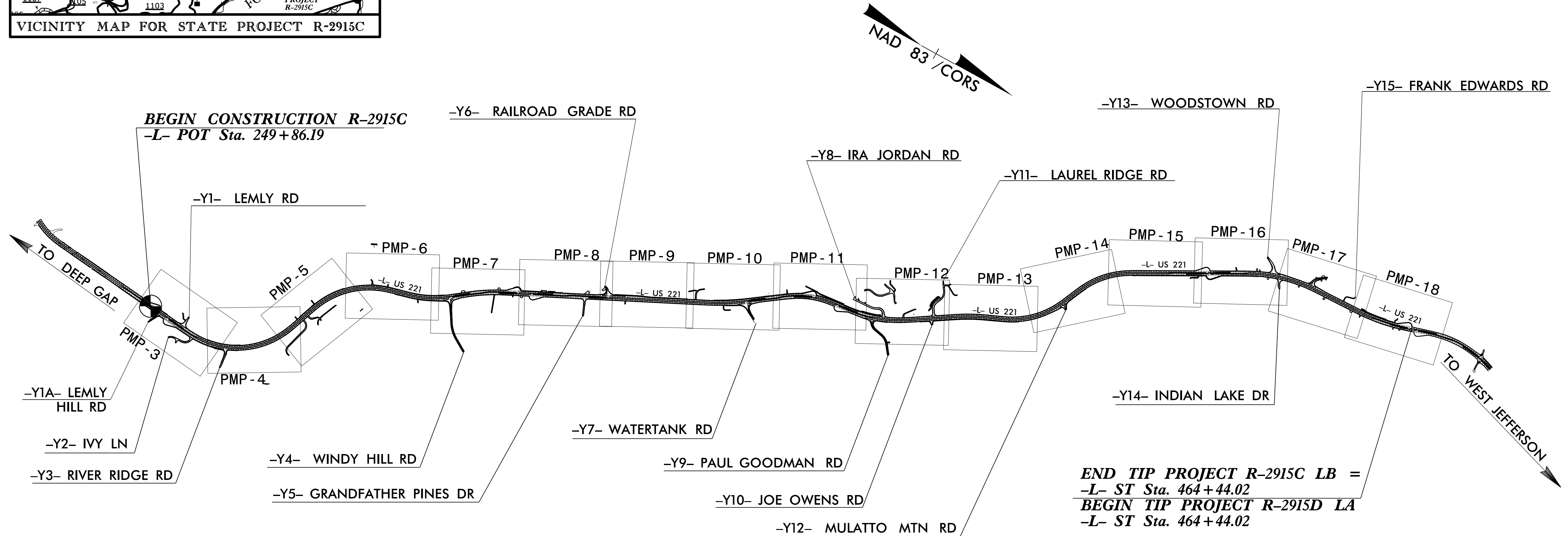

SEPI
ENGINEERING & CONSTRUCTION

1025 Wade Avenue
Raleigh, NC 27605
Tel: 919-789-9977
Fax: 919-789-9591
License: C-2197

PLAN PREPARED FOR: N.C.D.O.T. SIGNING AND DELINEATION UNIT	
<u>KELVIN L. JORDAN</u>	SIGNING & DELINEATION REGIONAL ENGINEER
<u>DERRICK H. BEARD</u>	SIGNING & DELINEATION PROJECT DESIGN ENGINEER/TECHNICIAN

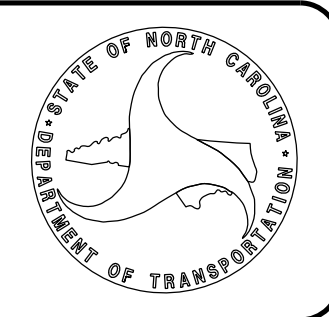

PLAN PREPARED BY: SEPI ENGINEERING & CONSTRUCTION	
<u>JOSEPH B. KOPASKIE, PE</u>	SIGNING & DELINEATION PROJECT ENGINEER
<u>RICHARD DRAYTON</u>	SIGNING & DELINEATION PROJECT DESIGN ENGINEER

INDEX	
SHEET NO.	DESCRIPTION
PMP-1	PAVEMENT MARKING PLAN TITLE AND INDEX SHEET
PMP-2	PAVEMENT MARKING SCHEDULE, GENERAL NOTES AND ROADWAY STANDARD DRAWING SCHEDULE SHEET
PMP-3 THRU PMP-18	PAVEMENT MARKING DETAIL

TIP NO. R - 2915C	SHEET NO. PMP - 2
APPROVED: <u>Joseph Kopasick</u> <small>REGISTERED PROFESSIONAL ENGINEER</small> DATE: 6/29/2016	
SEAL 	
DOCUMENT NOT CONSIDERED FINAL UNLESS ALL SIGNATURES COMPLETED	

PAVEMENT MARKING SCHEDULE

<u>SYMBOL</u>	<u>DESCRIPTION</u>	
TU	WHITE DIAGONAL	<u>THERMOPLASTIC(12", 90 MILS)</u>
T2	WHITE STOPBAR	<u>THERMOPLASTIC(24", 120 MILS)</u>
V8	2 FT. - 6 FT./SP WHITE MINISKIP	<u>POLYUREA (4") With Highly Reflective Elements</u>
V9	2 FT. - 6 FT./SP YELLOW MINISKIP	
VA	WHITE EDGELINE	
VB	YELLOW EDGELINE	
VC	10 FT. WHITE SKIP	
VD	3 FT. - 9 FT./SP WHITE MINISKIP	
VE	WHITE SOLID LANE LINE	<u>POLYUREA (8") With Highly Reflective Elements</u>
VI	YELLOW DOUBLE CENTER	
V13	3 FT. - 9 FT./SP WHITE MINISKIP	
VN	WHITE GORELINE	<u>THERMOPLASTICPAVEMENT MARKING CHARACTER (120 MILS)</u>
VR	WHITE SOLID LANE LINE	
UI	ALPHANUMERIC CHAR.	<u>THERMOPLASTICPAVEMENT MARKING SYMBOLS (90 MILS)</u>
UA	LEFT TURN ARROW	<u>SNOWFLOWABLE RAISED PAVEMENT MARKERS</u>
UB	RIGHT TURN ARROW	
UT	U-TURN ARROW	
ME	YELLOW & YELLOW	
MF	CRYSTAL & RED	

GENERAL NOTES

THE FOLLOWING GENERAL NOTES APPLY AT ALL TIMES FOR THE DURATION OF THE CONSTRUCTION PROJECT, EXCEPT WHEN OTHERWISE NOTED IN THE PLAN, OR DIRECTED BY THE ENGINEER.

A) INSTALL PAVEMENT MARKINGS AND PAVEMENT MARKERS ON THE FINAL SURFACE AS FOLLOWS:

ROAD NAME	MARKING	MARKER
US HWY 221	POLYUREA WITH HIGHLY REFLECTIVE ELEMENTS	SNOWFLOWABLE RAISED
ALL -Y- LINES	POLYUREA WITH HIGHLY REFLECTIVE ELEMENTS	SNOWFLOWABLE RAISED

B) TIE PROPOSED PAVEMENT MARKING LINES TO EXISTING PAVEMENT MARKING LINES.

C) REMOVE/REPLACE ANY CONFLICTING/DAMAGED PAVEMENT MARKINGS AND MARKERS.

D) PASSING ZONES WILL BE DETERMINED IN THE FIELD AND MUST BE APPROVED BY THE ENGINEER.

E) STOP BAR LOCATION AT NON-SIGNALIZED INTERSECTIONS MAY BE ADJUSTED AS DIRECTED BY THE ENGINEER.

F) UNLESS OTHERWISE SPECIFIED, HEATED-IN-PLACE THERMOPLASTIC MAY BE USED IN LIEU OF EXTRUDED THERMOPLASTIC FOR STOP BARS, SYMBOLS, CHARACTERS AND DIAGONALS. IF HEATED-IN-PLACE IS USED, IT SHALL BE PAID FOR USING THE EXTRUDED THERMOPLASTIC PAY ITEM.

ROADWAY STANDARD DRAWING

THE FOLLOWING ROADWAY STANDARDS AS APPEAR IN "ROADWAY STANDARD DRAWINGS" - PROJECT SERVICES UNIT - N.C. DEPARTMENT OF TRANSPORTATION - RALEIGH, N.C., DATED JANUARY 2012 ARE APPLICABLE TO THIS PROJECT AND BY REFERENCE HEREBY ARE CONSIDERED A PART OF THESE PLANS:

<u>STD. NO.</u>	<u>TITLE</u>
1205.01	PAVEMENT MARKINGS - LINE TYPES AND OFFSETS
1205.02	PAVEMENT MARKINGS - TWO-LANE AND MULTILANE ROADWAYS
1205.04	PAVEMENT MARKINGS - INTERSECTIONS
1205.05	PAVEMENT MARKINGS - TURN LANES
1205.06	PAVEMENT MARKINGS - LANE DROPS
1205.08	PAVEMENT MARKINGS - SYMBOLS AND WORD MESSAGES
1205.09	PAVEMENT MARKINGS - PAINTED ISLANDS
1250.01	RAISED PAVEMENT MARKERS - INSTALLATION SPACING
1253.01	RAISED PAVEMENT MARKERS - SNOWFLOWABLE
1261.01	GUARDRAIL AND BARRIER DELINEATORS - INSTALLATION SPACING
1261.02	GUARDRAIL AND BARRIER DELINEATORS - TYPES AND MOUNTING
1262.01	GUARDRAIL END DELINEATION

**PAVEMENT MARKING SCHEULE
GENERAL NOTES AND ROADWAY
STANDARD DRAWING SCHEDULE**

TIP NO. R-2915C	SHEET NO. PMP-3
APPROVED: <i>Joseph Kopaske</i> SC928AEF89AS4FA...	
DATE: 6/29/2016	
SEAL	
	
DOCUMENT NOT CONSIDERED FINAL UNLESS ALL SIGNATURES COMPLETED	

END TIP PROJECT R-2915B LB =
-L- POT Sta. 251+72.02
BEGIN TIP PROJECT R-2915C LA
-L- POT Sta. 254+36.94

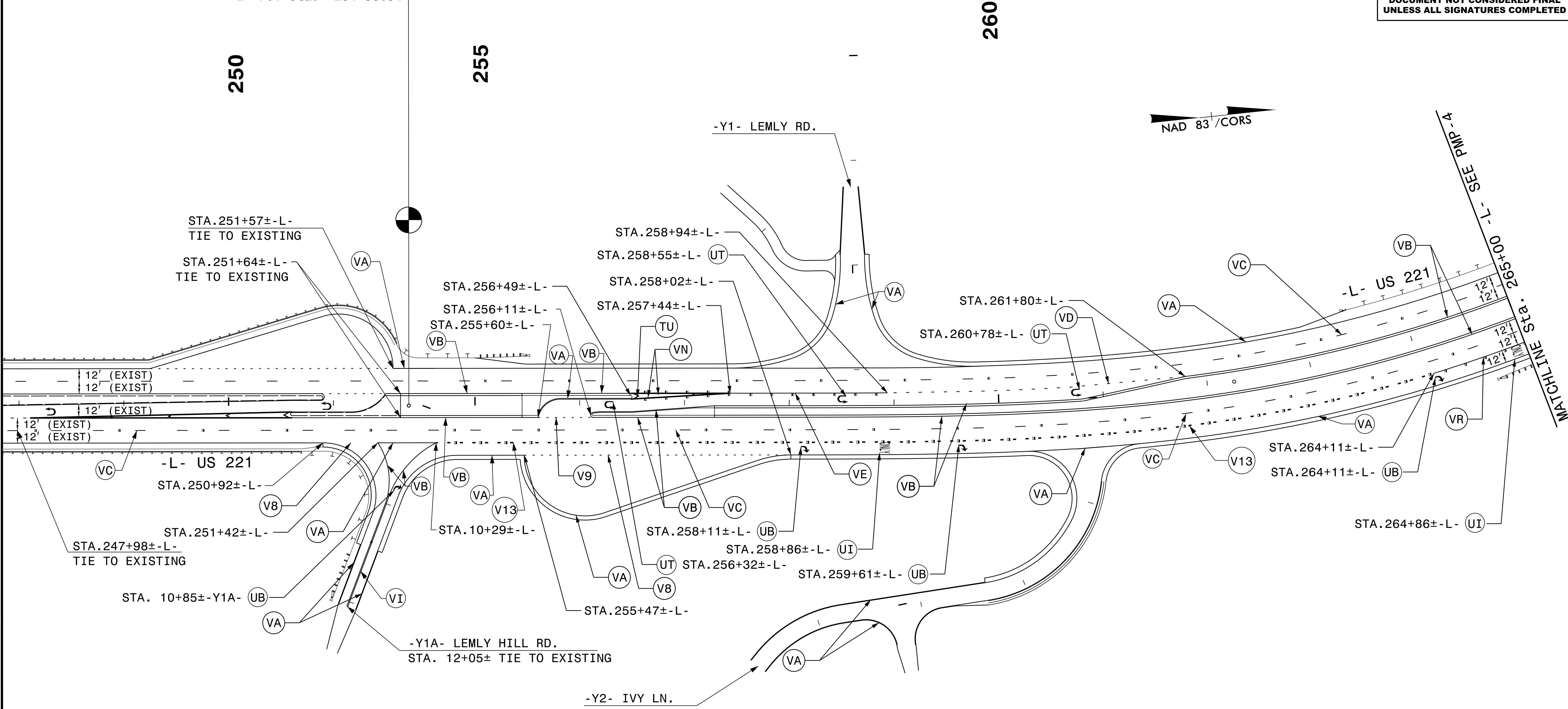

PAVEMENT MARKING DETAIL

6/29/2016
Pavement Marking\PM-3.dgn
USER:Rejs

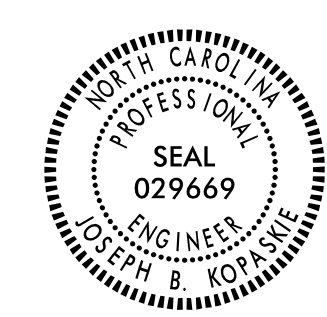
TIP NO. R-2915C	SHEET NO. PMP-4
APPROVED: <i>Joseph Kopaskie</i> <small>SCDREAEF89ASFA...</small>	
DATE: 6/29/2016	
SEAL	
	
DOCUMENT NOT CONSIDERED FINAL UNLESS ALL SIGNATURES COMPLETED	

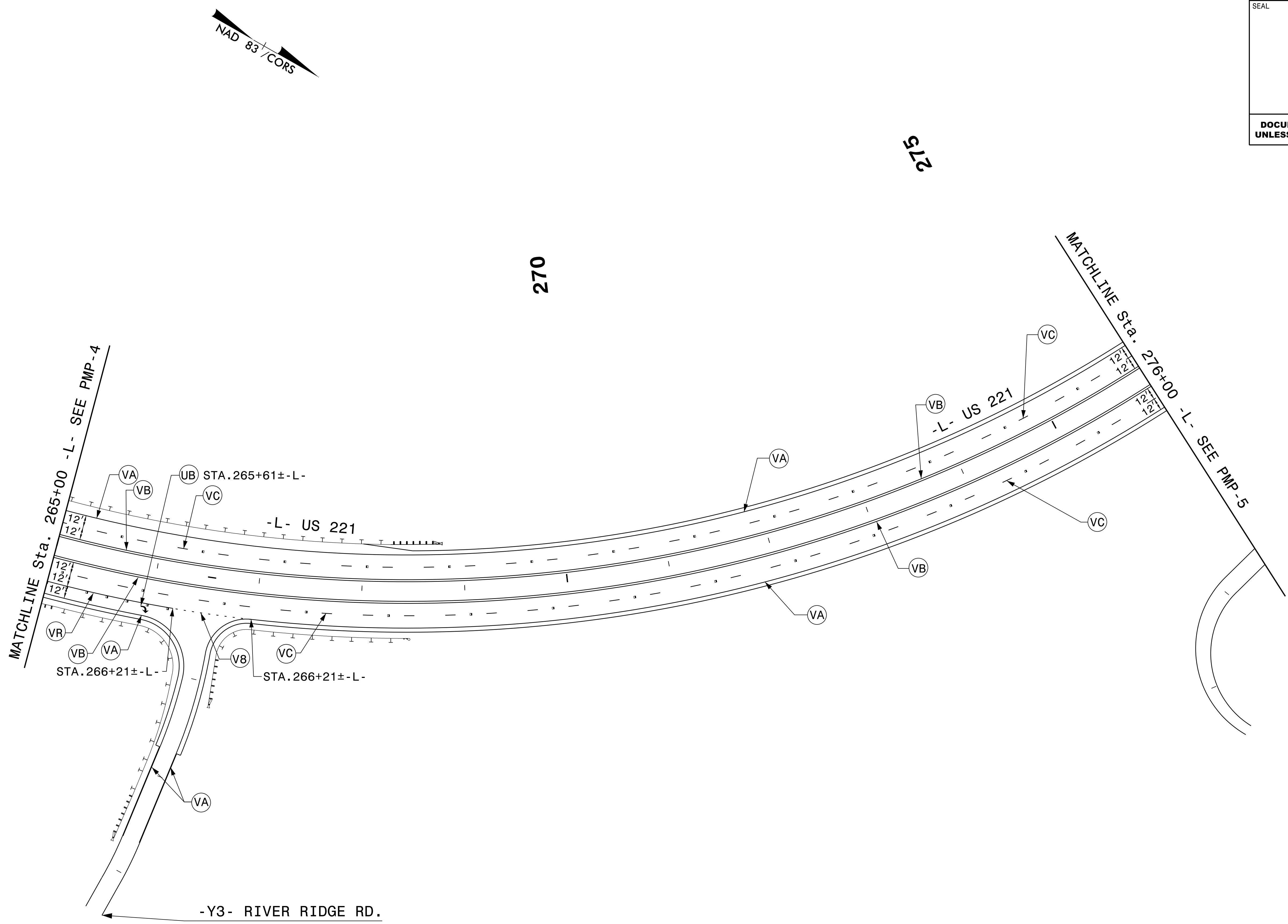

6/29/2016
Pavement Marking PMP-4.dgn
USER: rjg

PAVEMENT MARKING DETAIL

TIP NO. R-2915C	SHEET NO. PMP-5
APPROVED: <i>Joseph Kopaskie</i> <small>SC029669040A...</small>	
DATE: 6/29/2016	
SEAL	
	
DOCUMENT NOT CONSIDERED FINAL UNLESS ALL SIGNATURES COMPLETED	

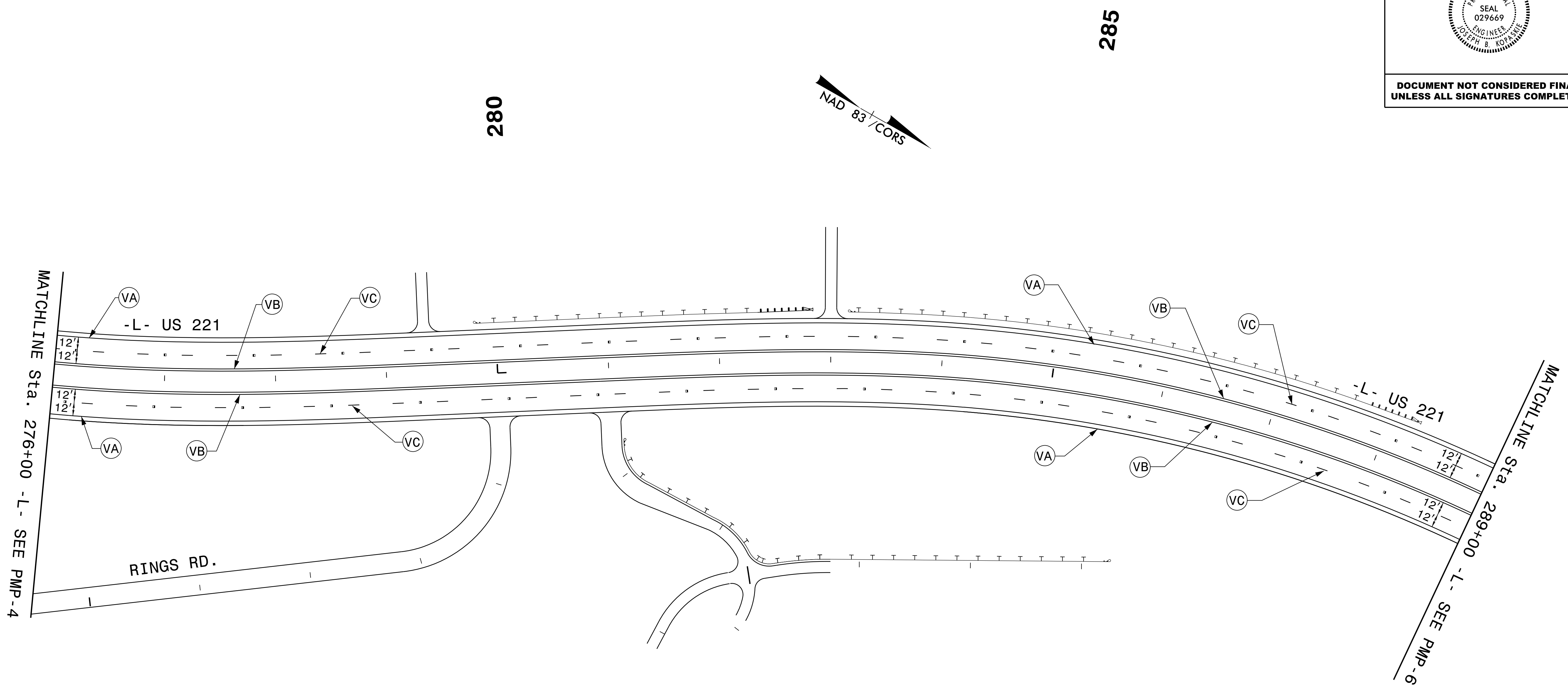

6/29/2016
Pavement Marking\PM-5.dgn
USER:Rejs

PAVEMENT MARKING DETAIL

TIP NO. R-2915C	SHEET NO. PMP-6
APPROVED: <i>Joseph Kopaske</i> <small>SCDREAEF89AS4FA...</small>	
DATE: 6/29/2016	
SEAL	
	
DOCUMENT NOT CONSIDERED FINAL UNLESS ALL SIGNATURES COMPLETED	

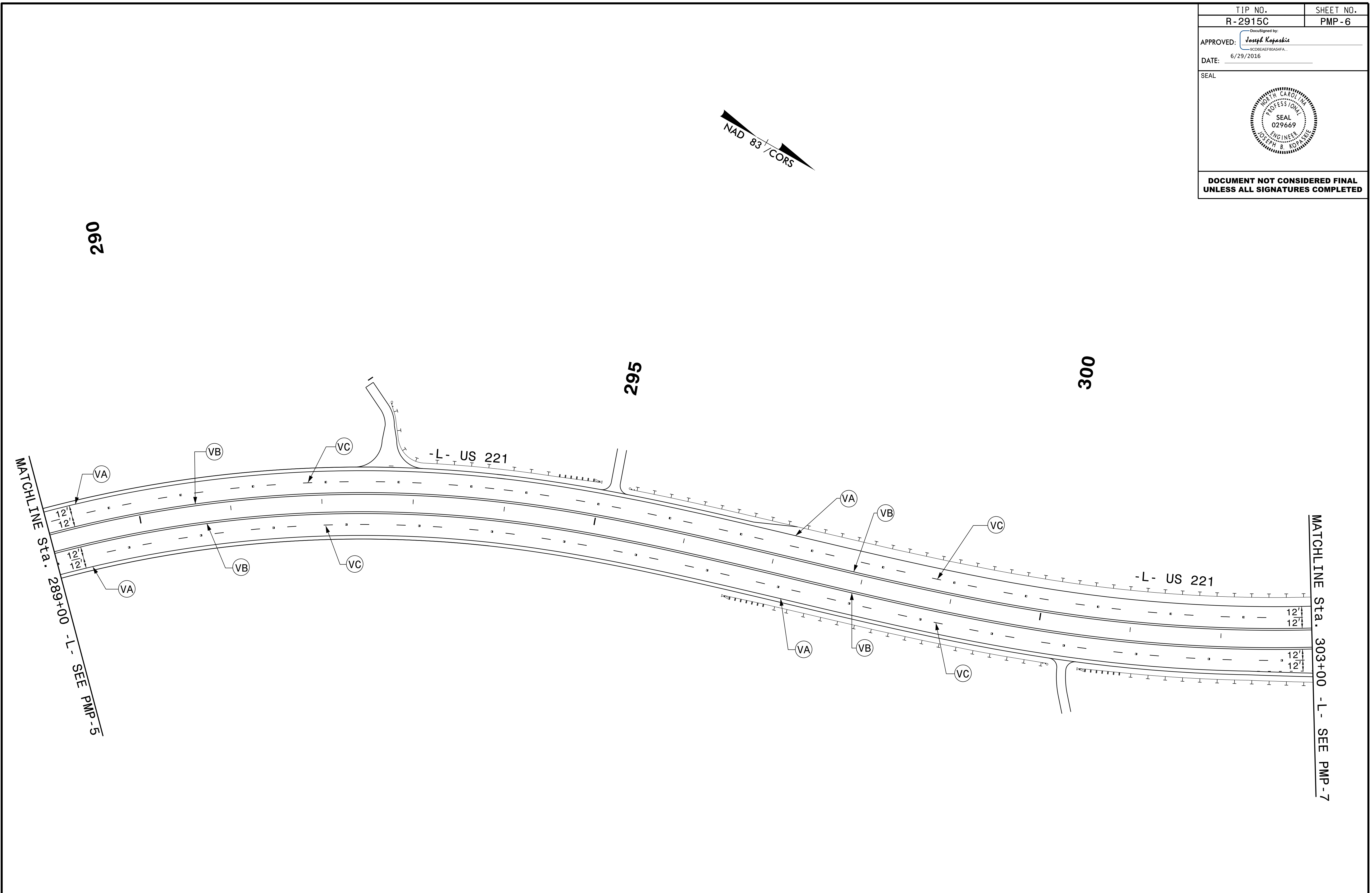
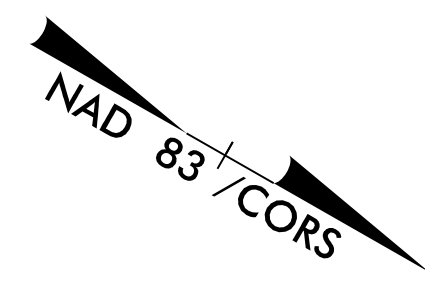

6/29/2016
Pavement Marking\PM-6.dgn
USER:Rejs

PAVEMENT MARKING DETAIL

TIP NO. R-2915C	SHEET NO. PMP-7
APPROVED: <i>Joseph Kopaske</i> SCDREAF89AS4FA	
DATE: 6/29/2016	
SEAL	
DOCUMENT NOT CONSIDERED FINAL UNLESS ALL SIGNATURES COMPLETED	

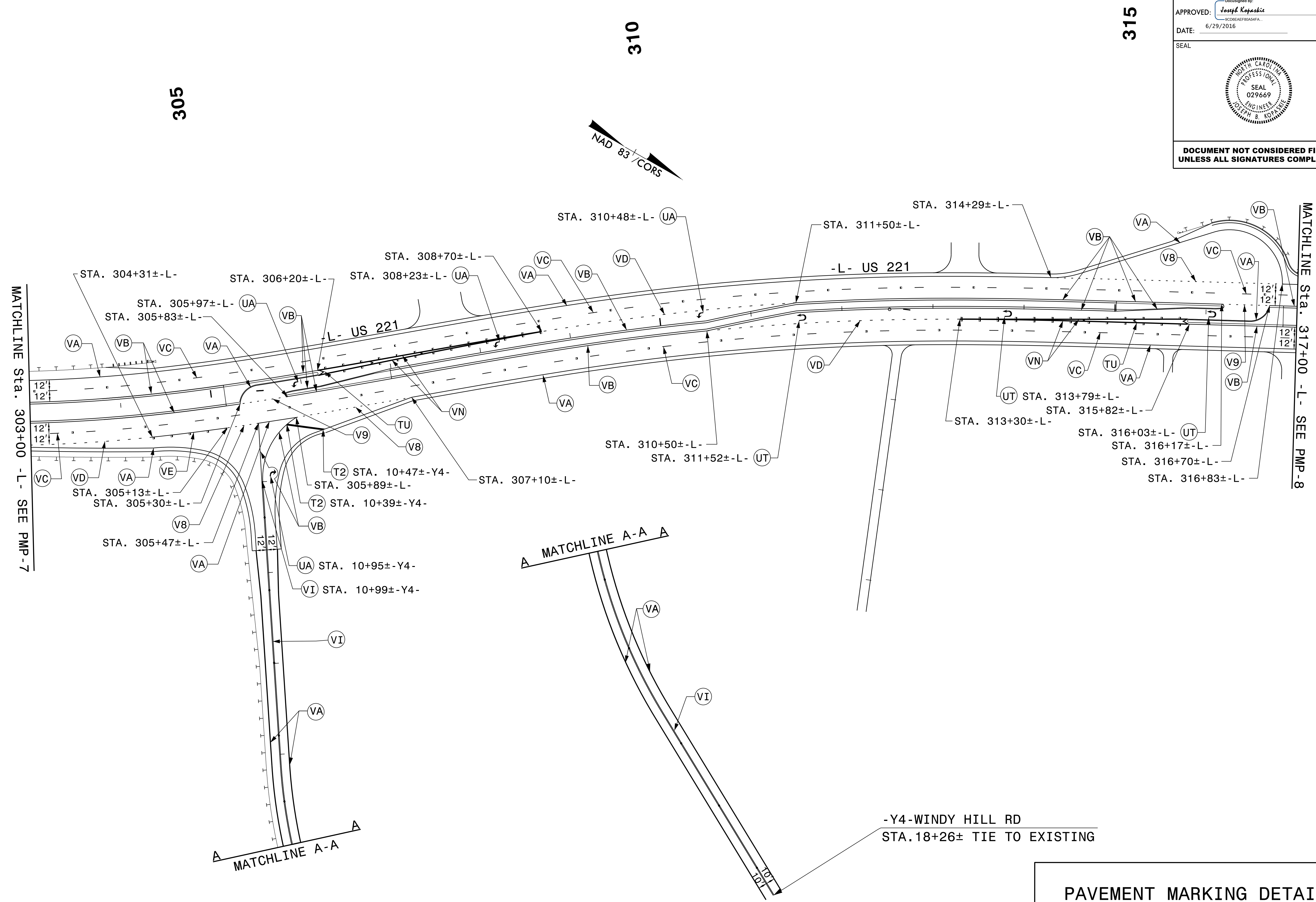

6/29/2016 10:00 AM
C:\Users\jkopaske\Documents\Project\PM-7.dgn
jkopaske

PAVEMENT MARKING DETAIL

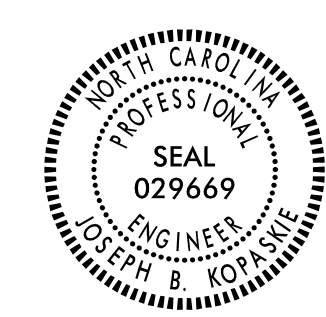
TIP NO. R-2915C	SHEET NO. PMP-8
APPROVED: <i>Joseph Kopaskie</i> SCDREAEF89ASFA...	
DATE: 6/29/2016	
SEAL	
	
DOCUMENT NOT CONSIDERED FINAL UNLESS ALL SIGNATURES COMPLETED	

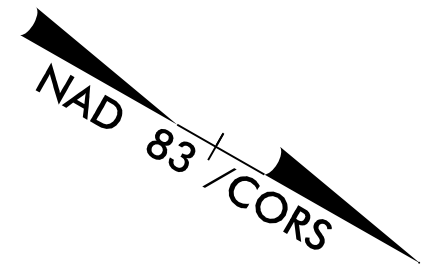

320

325

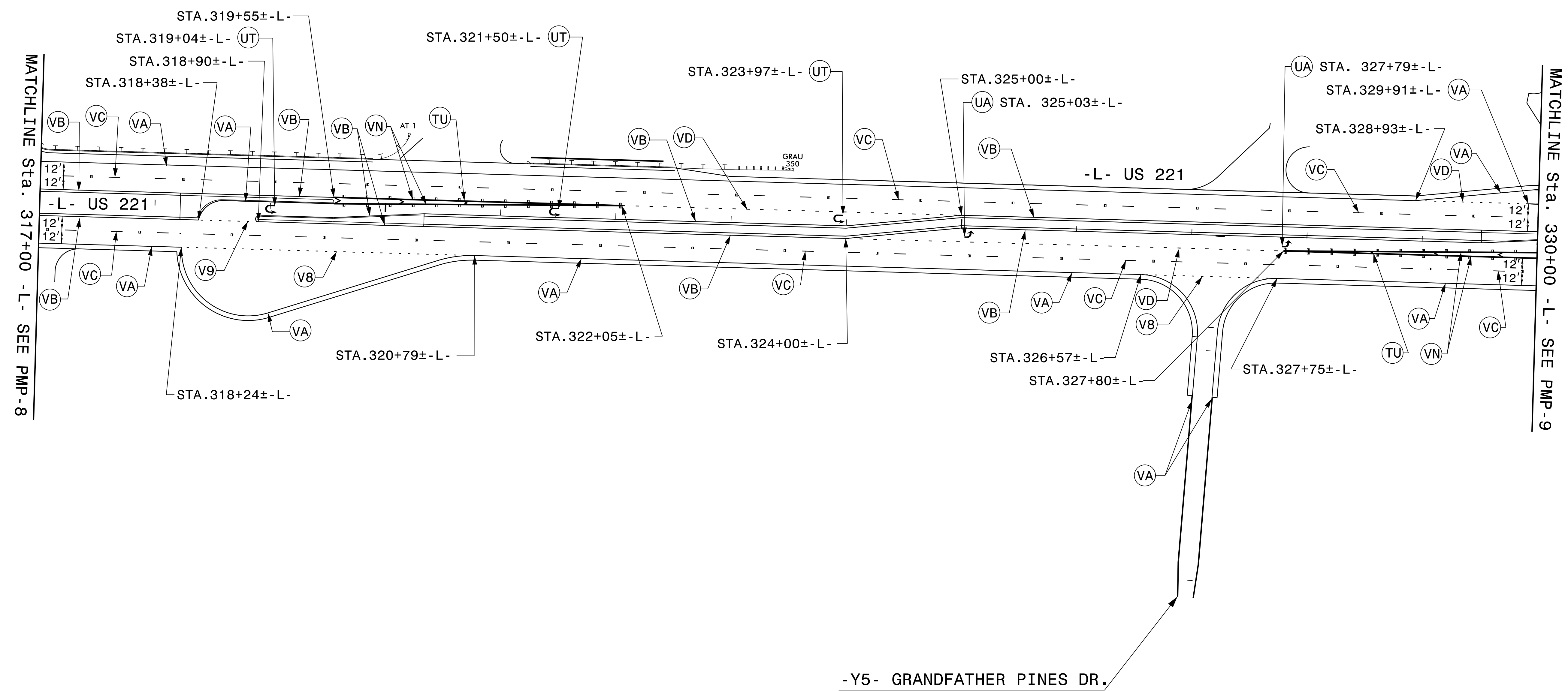

6/29/2016
Pavement Marking\PM-8.dgn
USER:Rejs

PAVEMENT MARKING DETAIL

TIP NO. R-2915C	SHEET NO. PMP-9
APPROVED: <i>Joseph Kopaskie</i> <small>SCDREAEF89AS4FA...</small>	
DATE: 6/29/2016	
SEAL	
	
DOCUMENT NOT CONSIDERED FINAL UNLESS ALL SIGNATURES COMPLETED	

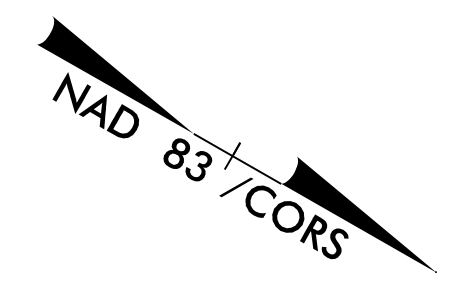

335

340

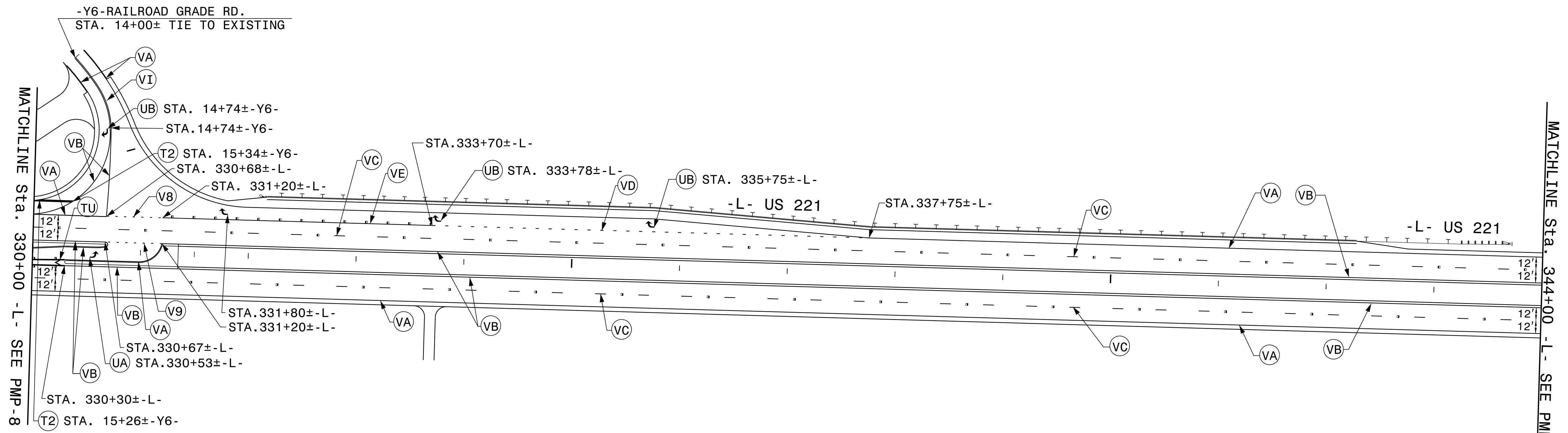

6/29/2016
Pavement Marking PMP-9.dgn
USER: Nejs

PAVEMENT MARKING DETAIL

TIP NO. R-2915C	SHEET NO. PMP-10
APPROVED: <i>Joseph Kopaskie</i> <small>DocuSigned by: SCDEAEF89AS4FA...</small>	
DATE: 6/29/2016	
SEAL 	
DOCUMENT NOT CONSIDERED FINAL UNLESS ALL SIGNATURES COMPLETED	

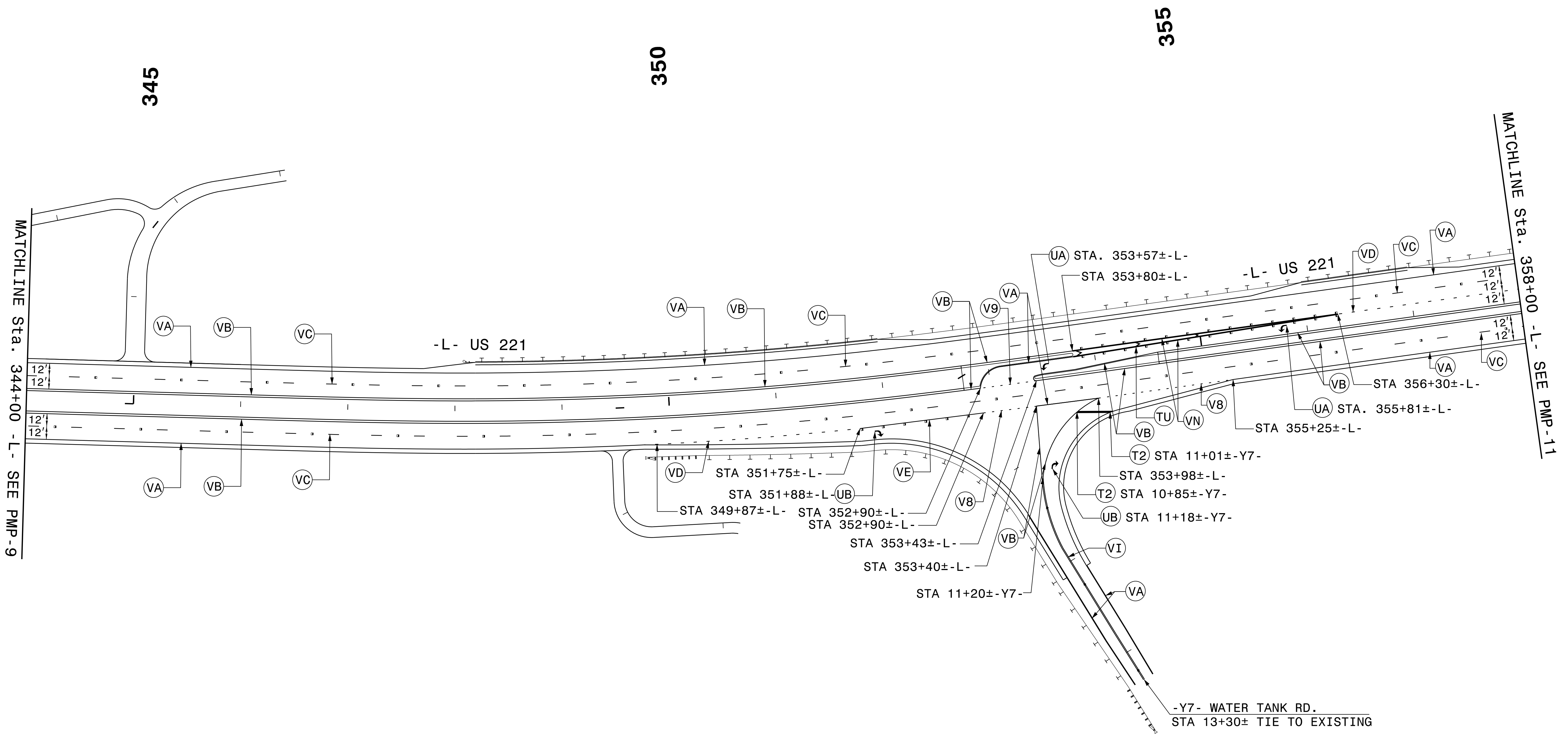
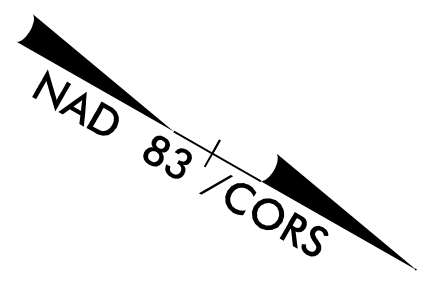

6/29/2016
Pavement Marking PMP-10.dgn
USER: rjg

PAVEMENT MARKING DETAIL

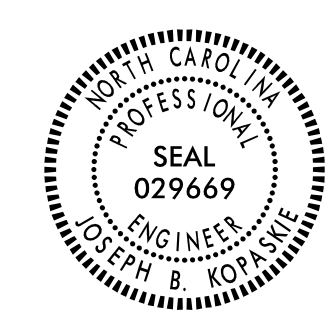
TIP NO. R-2915C	SHEET NO. PMP-11
APPROVED: <i>Joseph Kopaske</i> SCDREAEF89ASFA...	
DATE: 6/29/2016	
SEAL	
	
DOCUMENT NOT CONSIDERED FINAL UNLESS ALL SIGNATURES COMPLETED	

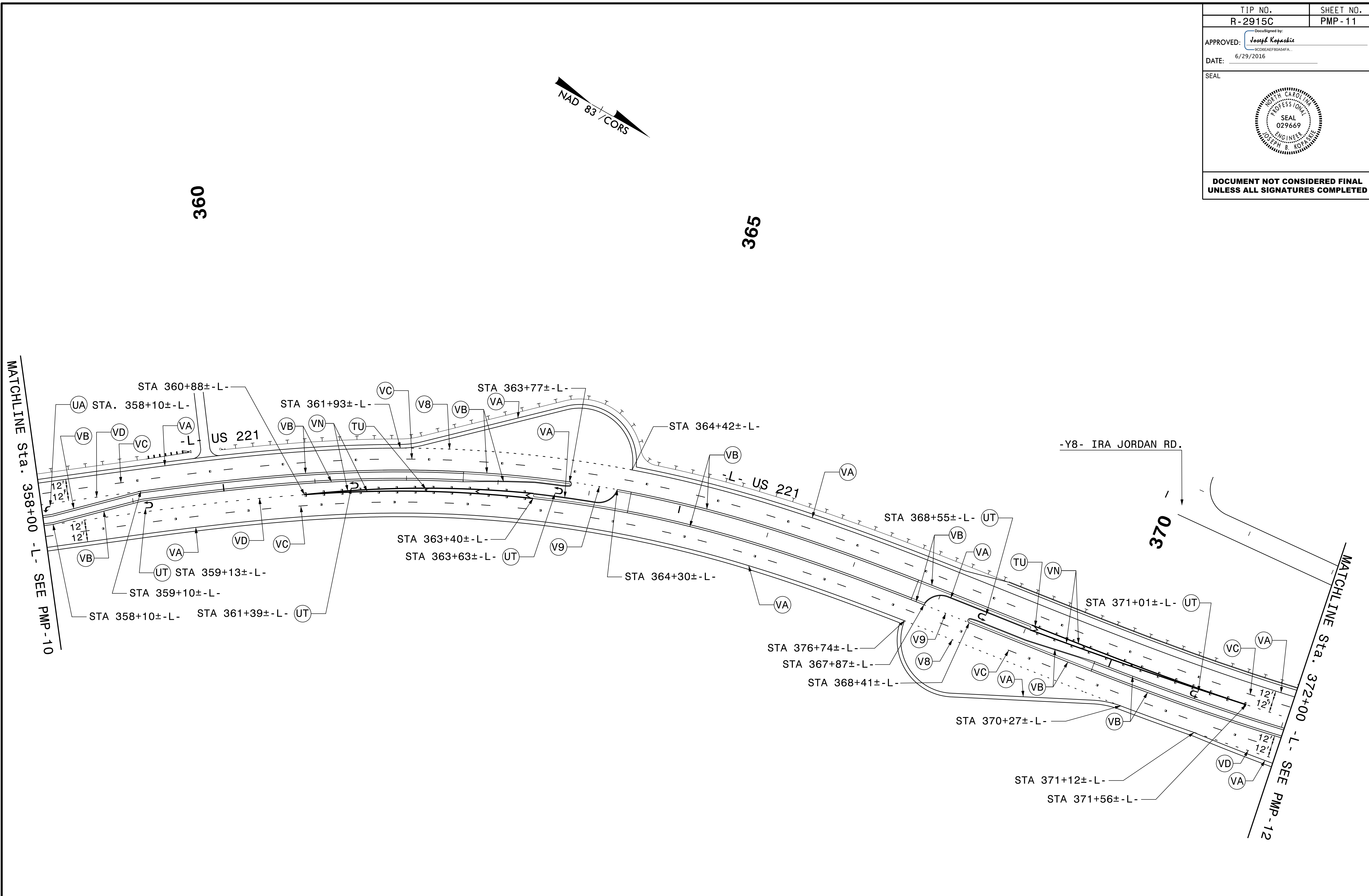
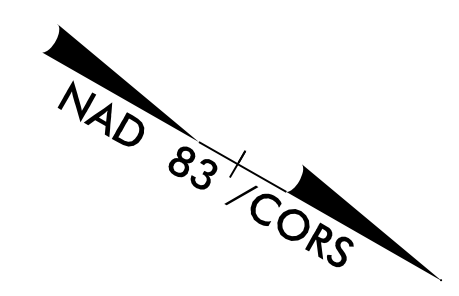

PAVEMENT MARKING DETAIL

TIP NO. R-2915C	SHEET NO. PMP-12
APPROVED: <i>Joseph Koskiewicz</i>	
DATE: 6/29/2016	
	
DOCUMENT NOT CONSIDERED FINAL UNLESS ALL SIGNATURES COMPLETED	

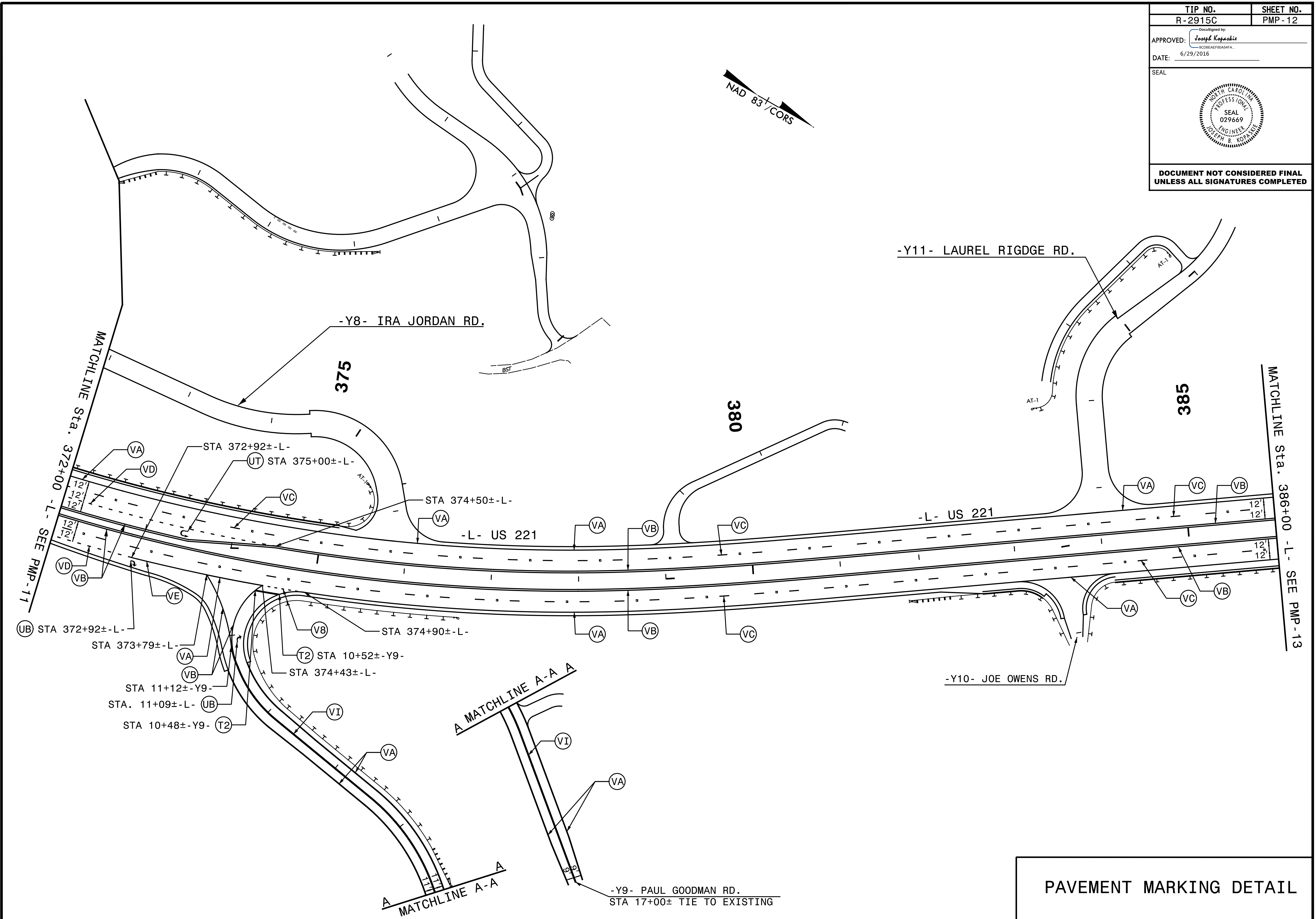
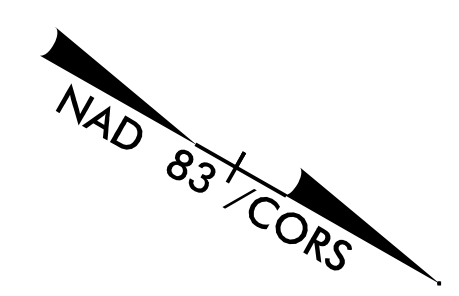

11
10
9
8
7
6
5
4
3
2
1

PAVEMENT MARKING DETAIL

TIP NO. R-2915C	SHEET NO. PMP-13
APPROVED: <i>Joseph Kopaske</i> SCDEAEF89AS4FA...	
DATE: 6/29/2016	
SEAL	
	
DOCUMENT NOT CONSIDERED FINAL UNLESS ALL SIGNATURES COMPLETED	

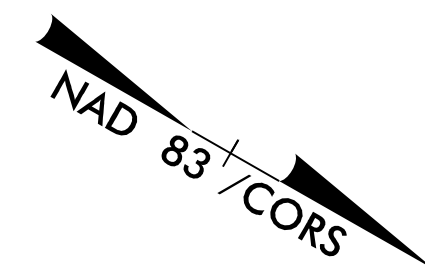

390

395

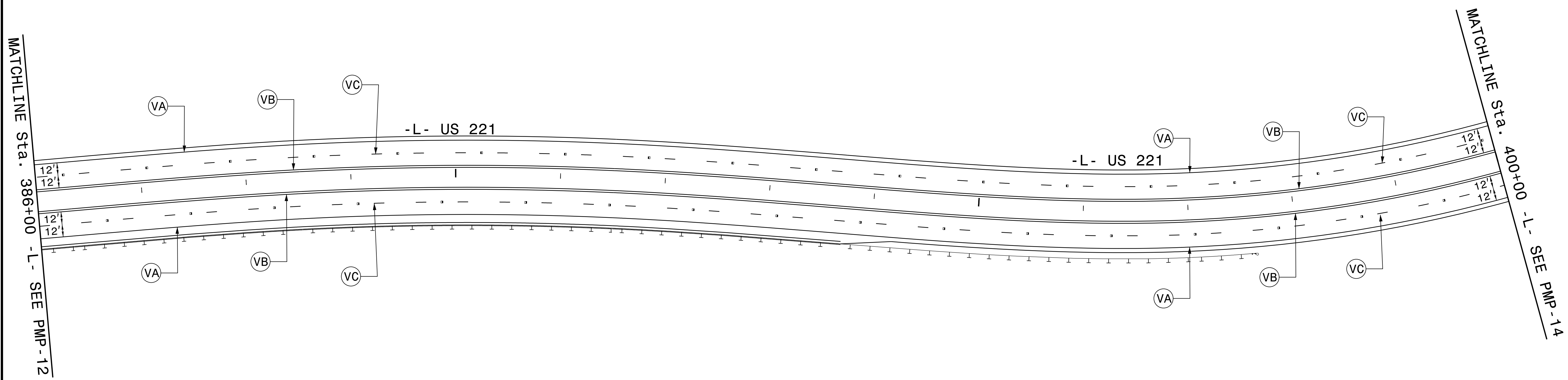

6/29/2016
Pavement Marking\PM-13.dgn
USER: rjg

PAVEMENT MARKING DETAIL

TIP NO. R-2915C	SHEET NO. PMP-14
APPROVED: <i>Joseph Kopaske</i> <small>SCDREAEF89ASFA...</small>	
DATE: 6/29/2016	
SEAL	
	
DOCUMENT NOT CONSIDERED FINAL UNLESS ALL SIGNATURES COMPLETED	

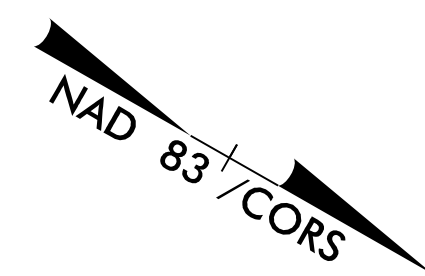

410

504

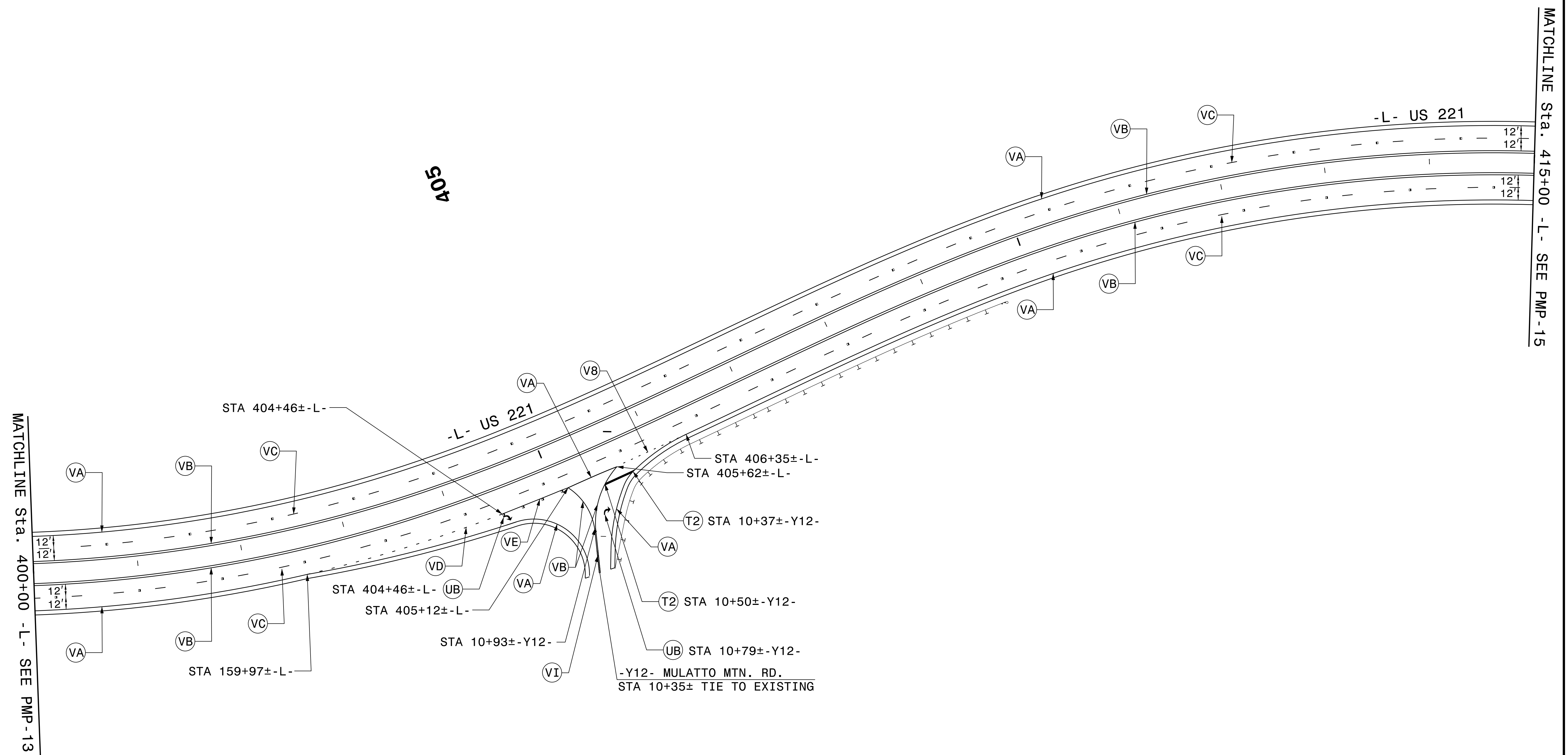

6/29/2016
Pavement Marking PMP-14.dgn
USER: rjg

PAVEMENT MARKING DETAIL

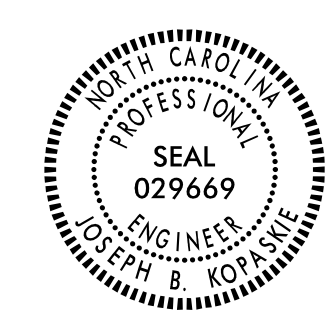
TIP NO. R-2915C	SHEET NO. PMP-15
APPROVED: <i>Joseph Kopaske</i> <small>SCDREAEF89AS4FA...</small>	
DATE: 6/29/2016	
SEAL	
	
DOCUMENT NOT CONSIDERED FINAL UNLESS ALL SIGNATURES COMPLETED	

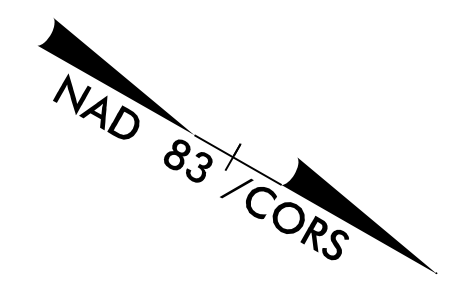

420

425

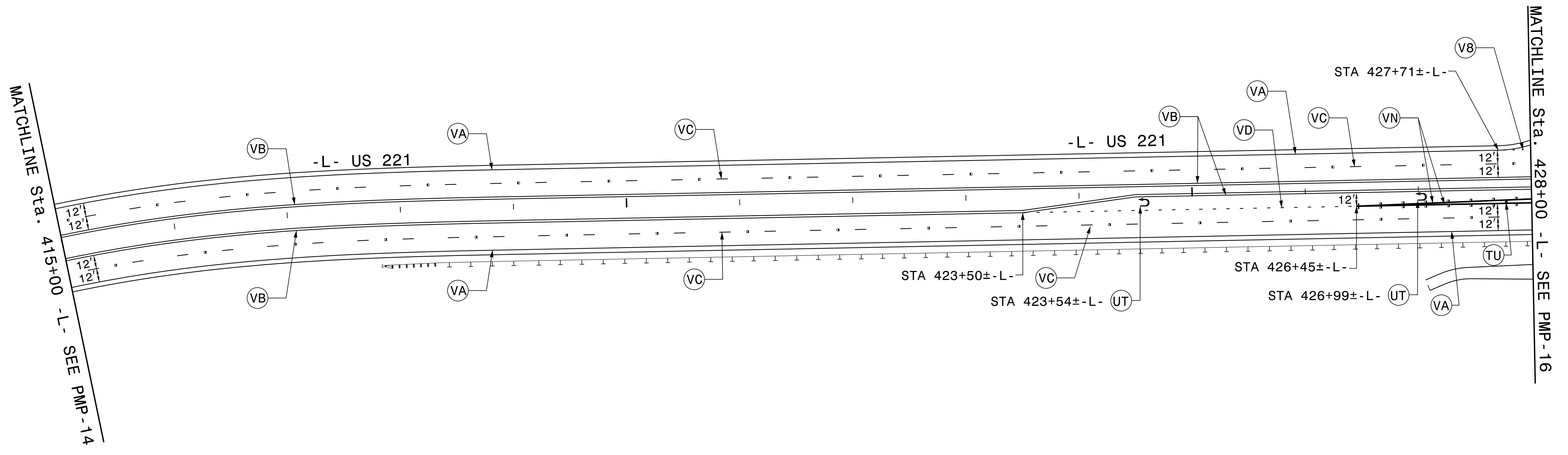

PAVEMENT MARKING DETAIL

TIP NO. R-2915C	SHEET NO. PMP-16
APPROVED: <i>Joseph Kopaska</i> SCDEAEF89ASFA...	
DATE: 6/29/2016	
SEAL	
	
DOCUMENT NOT CONSIDERED FINAL UNLESS ALL SIGNATURES COMPLETED	

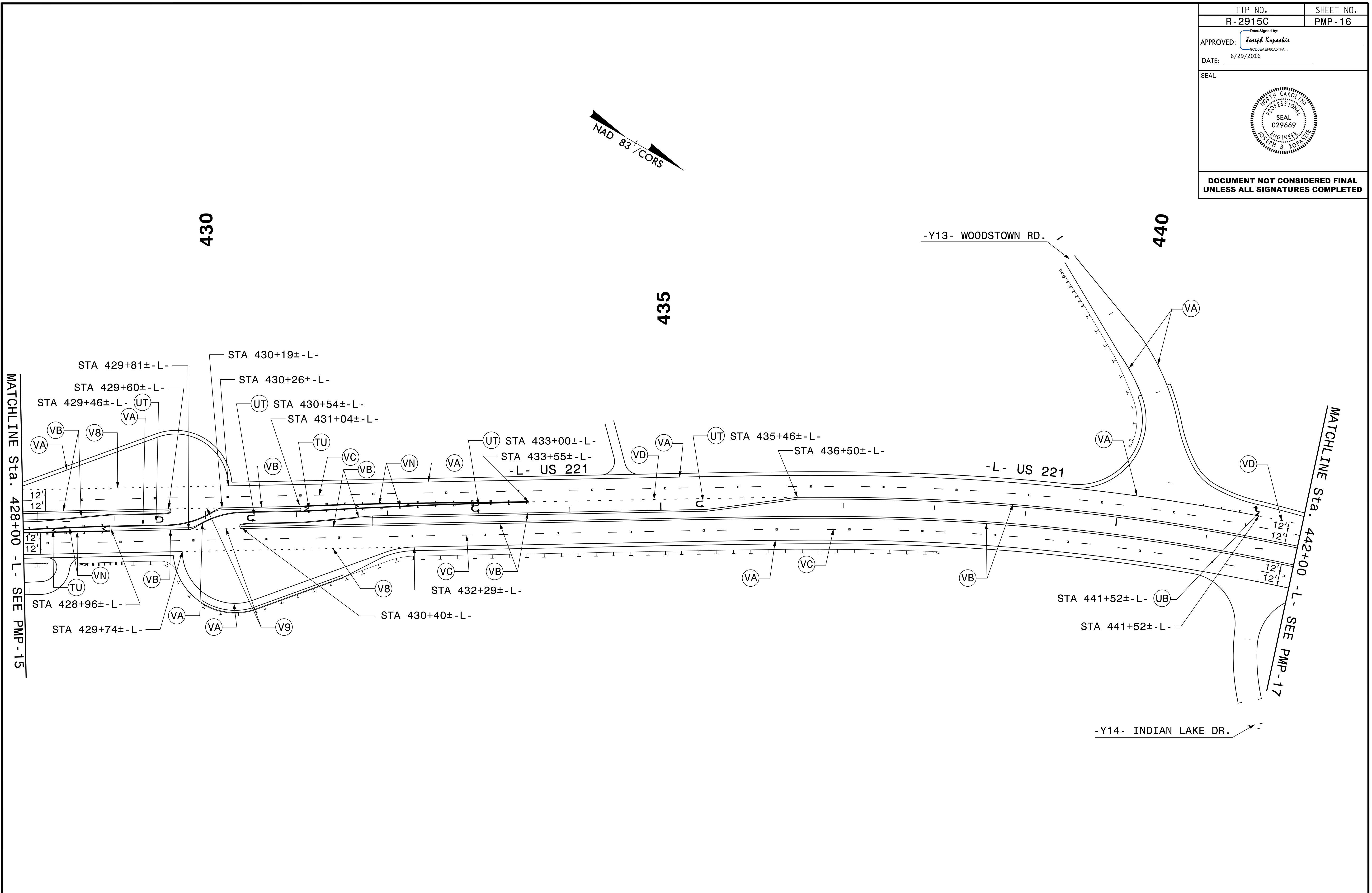
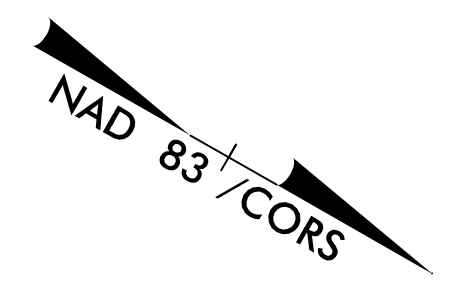

6/29/2016
Pavement Marking\PM-16.dgn
USER: RJS

PAVEMENT MARKING DETAIL

TIP NO. R-2915C	SHEET NO. PMP-18
APPROVED: <i>Joseph Kopaske</i> <small>SCDREAEF89AS4FA...</small>	
DATE: 6/29/2016	
SEAL	
	
DOCUMENT NOT CONSIDERED FINAL UNLESS ALL SIGNATURES COMPLETED	

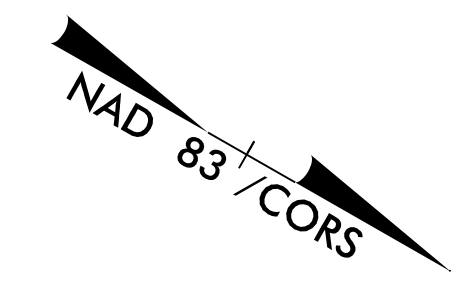

460

465

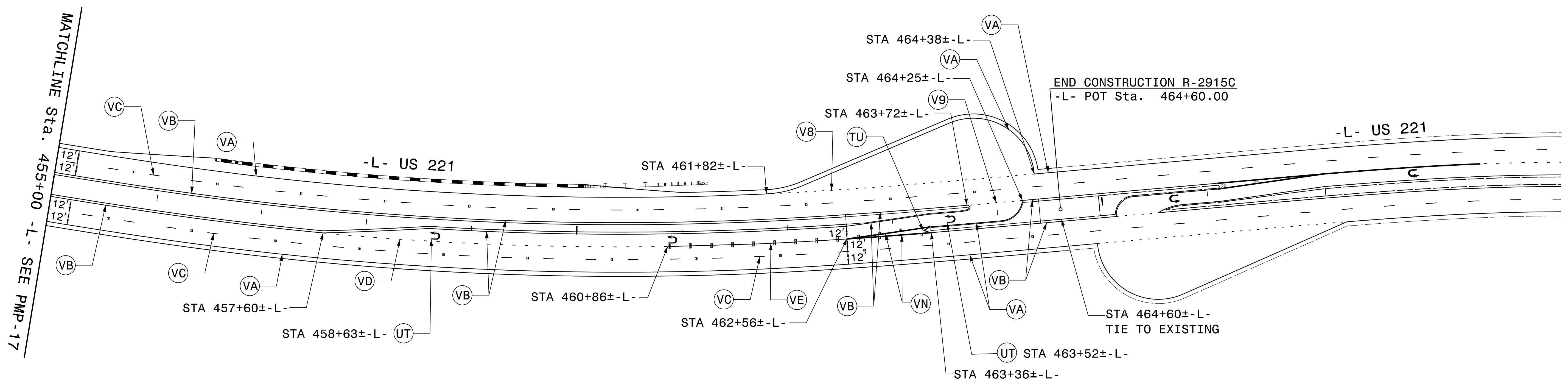

6/29/2016 10:00 AM
C:\Users\jkopaske\Documents\Projects\2016\460\460_PMP-18.dgn
jkopaske

PAVEMENT MARKING DETAIL