

8/17/99

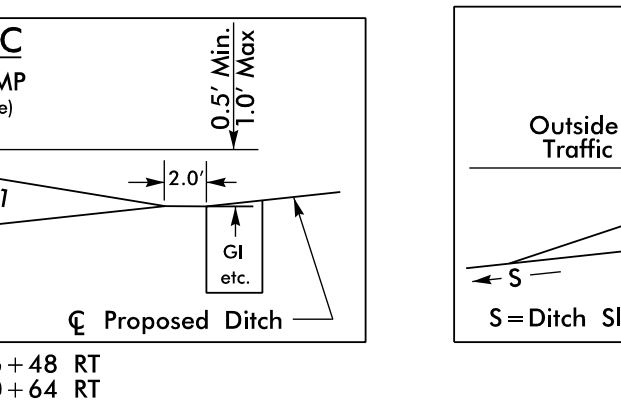
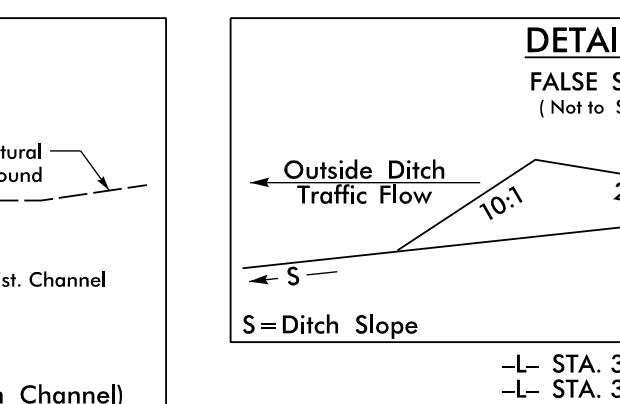
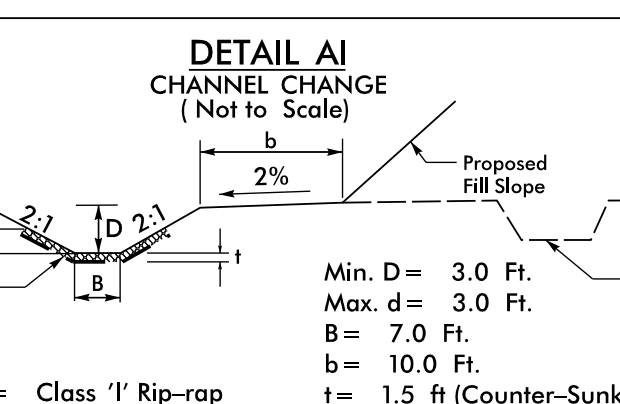
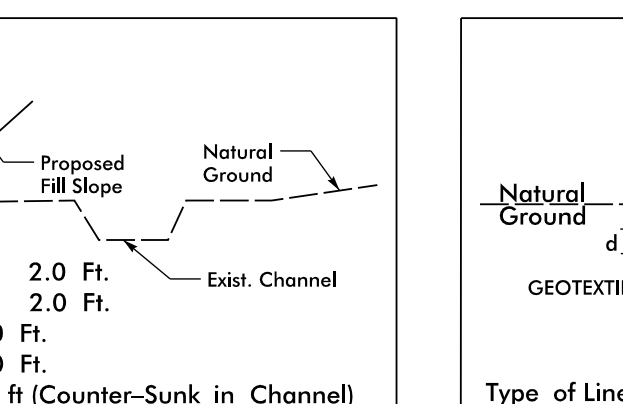
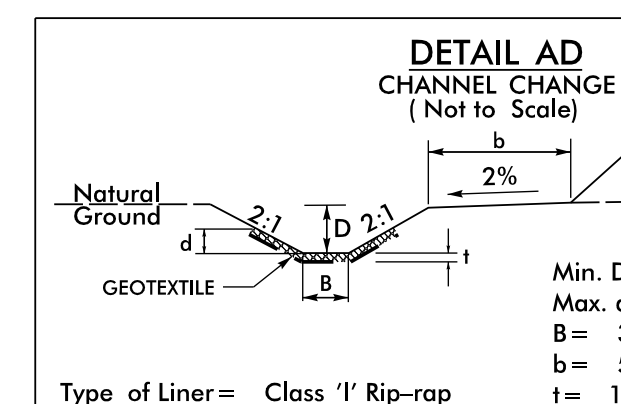
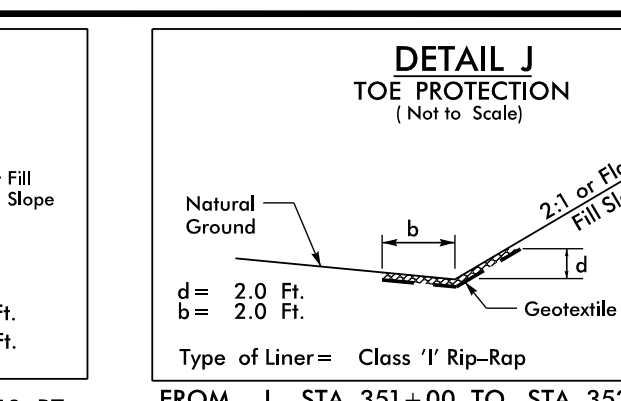
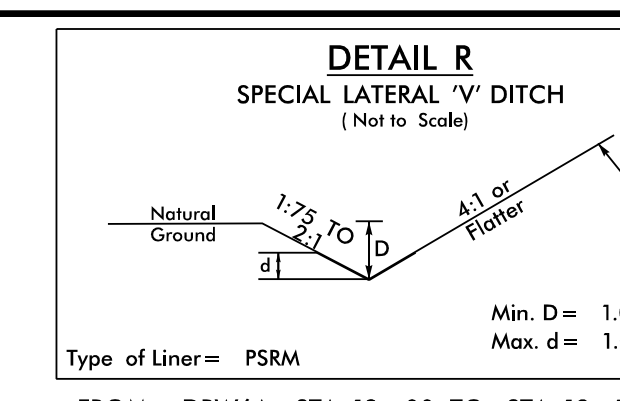
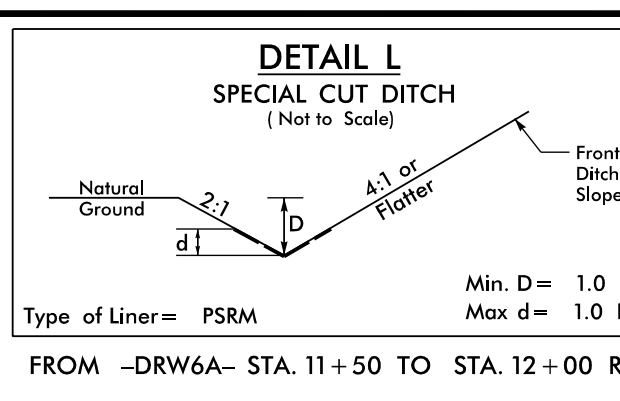
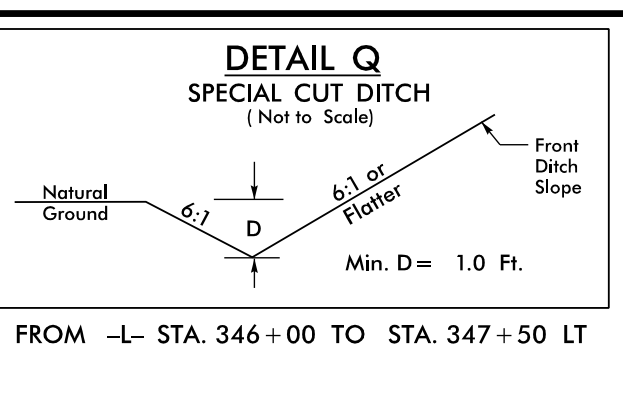
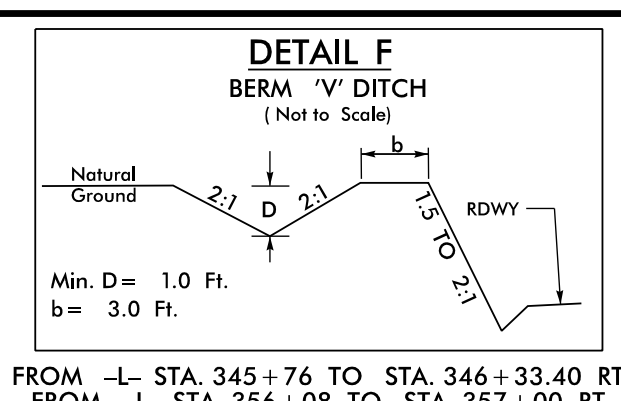

LOCHNER
H. W. LOCHNER, INC.
2840 PLAZA PLACE, SUITE 202
RALEIGH, NC 27612
(919)571-7111
NC License Number F-0159

HNTB
343 E. SIX FORKS ROAD, SUITE 200
RALEIGH, NC 27609
NC License Number C-1554

PROJECT REFERENCE NO. R-2915C SHEET NO. 11

ROADWAY DESIGN ENGINEER HYDRAULICS ENGINEER

9/1/2016

SEAL 25523

SEAL 15649

DOCUMENT NOT CONSIDERED FINAL UNLESS ALL SIGNATURES COMPLETED

REVISIONS

MATCH TO SHEET 10 -L- STA. 344+00.00

MATCH TO SHEET 12 -L- STA. 357+00.00

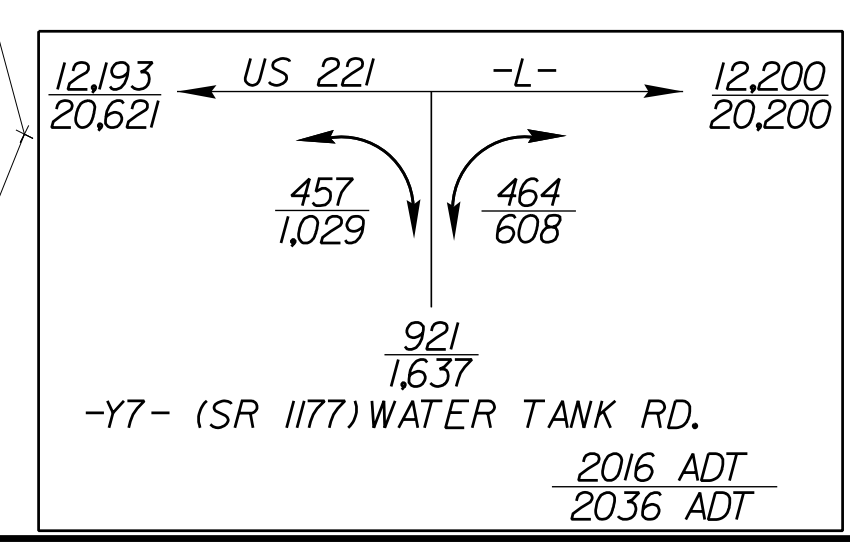
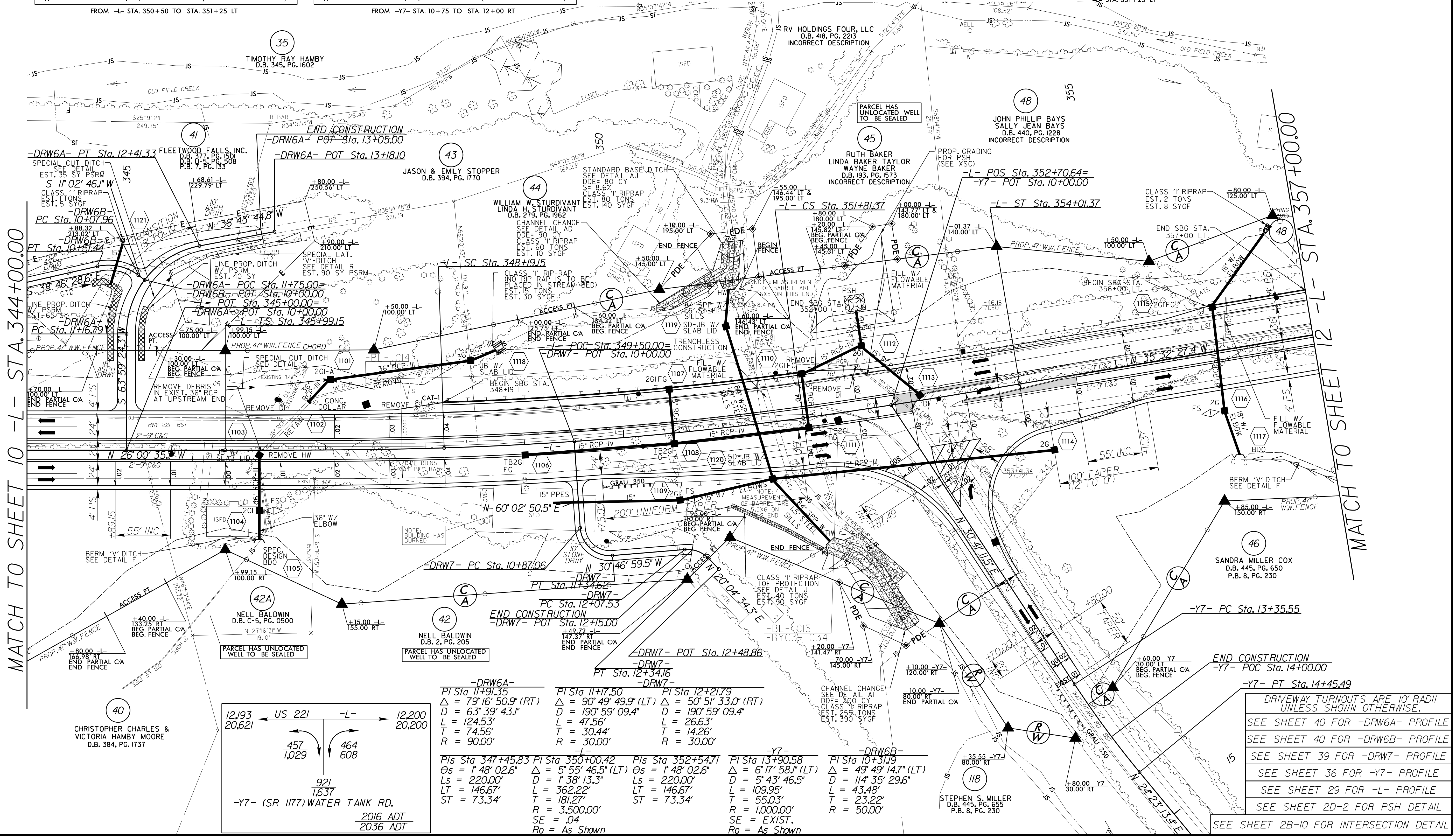

-DRW6A- PI Sta 11+91.35 Δ = 79° 16' 50.9" (RT) D = 63° 39' 43.1" L = 124.53' T = 74.56' R = 90.00'	PI Sta 11+7.50 Δ = 79° 49' 49.9" (LT) D = 190° 59' 09.4" L = 47.56' T = 30.44' R = 30.00'	PI Sta 12+21.79 Δ = 50° 51' 33.0" (RT) D = 190° 59' 09.4" L = 26.63' T = 14.26' R = 30.00'	-Y7- PI Sta 13+90.58 Δ = 6° 17' 58.1" (LT) D = 5° 43' 46.5" L = 109.95' T = 55.03' R = 1,000.00' SE = EXIST. Ro = As Shown	-DRW6B- PI Sta 10+31.19 Δ = 49° 49' 14.7" (LT) D = 114° 35' 29.6" L = 43.48' T = 23.22' R = 50.00'
--	--	---	--	--

DRIVEWAY TURNOUTS ARE 10' RADII UNLESS SHOWN OTHERWISE.

SEE SHEET 40 FOR -DRW6A- PROFILE

SEE SHEET 40 FOR -DRW6B- PROFILE

SEE SHEET 39 FOR -DRW7- PROFILE

SEE SHEET 36 FOR -Y7- PROFILE

SEE SHEET 29 FOR -L- PROFILE

SEE SHEET 2B-2 FOR PSH DETAIL

SEE SHEET 2B-10 FOR INTERSECTION DETAIL

22-AUG-2016 16:50
R:\Roadway\Projects\2915C_rdy_PSH11.dgn
3:33 PM