

**NOTES:**

REPAIR LOCATIONS AND ESTIMATE OF QUANTITIES ARE GIVEN WITH THE BEST INFORMATION AVAILABLE. IF ADDITIONAL REPAIRS NOT SHOWN ON THE DRAWINGS ARE DEEMED NECESSARY BY THE INSPECTOR OR ENGINEER THE CONTRACTOR SHALL NOTE ON THE DRAWINGS THE APPROXIMATE LOCATION AND DESCRIPTION OF THE REPAIRS AND ADJUST THE ACTUAL QUANTITIES ENTERED INTO THE REPAIR QUANTITY TABLE.

FOR CAP REPAIR DETAILS, SEE "TYPICAL CAP REPAIR DETAILS" SHEET.

FOR "SHOTCRETE REPAIRS", SEE SPECIAL PROVISIONS.

FOR "EPOXY RESIN INJECTION", SEE SPECIAL PROVISIONS.

**REPAIR QUANTITY TABLE**

REPAIRS BENT 4	QUANTITIES			
	ESTIMATE		ACTUAL	
SHOTCRETE REPAIRS	AREA SF	VOLUME CF	AREA SF	VOLUME CF
CAP (VERTICAL FACE)	1.2	0.5		
CAP (HORIZONTAL, CORNER)	0.0	0.0		
EPOXY RESIN INJECTION		LN. FT.		LN. FT.
CAP		0.0		

VALUES IN CHART REPRESENT ESTIMATED REPAIR TOTALS AFTER REMOVAL OF UNSOUND CONCRETE, MIN. OF 1" BEHIND REBAR AND MIN. 2" CL TO SAWCUT. SEE REPAIR DETAILS.



PLAN  
TOP OF CAP

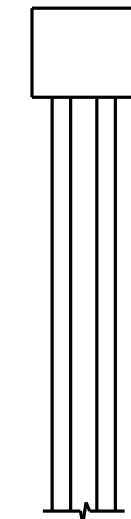

END VIEW  
NORTH SIDE

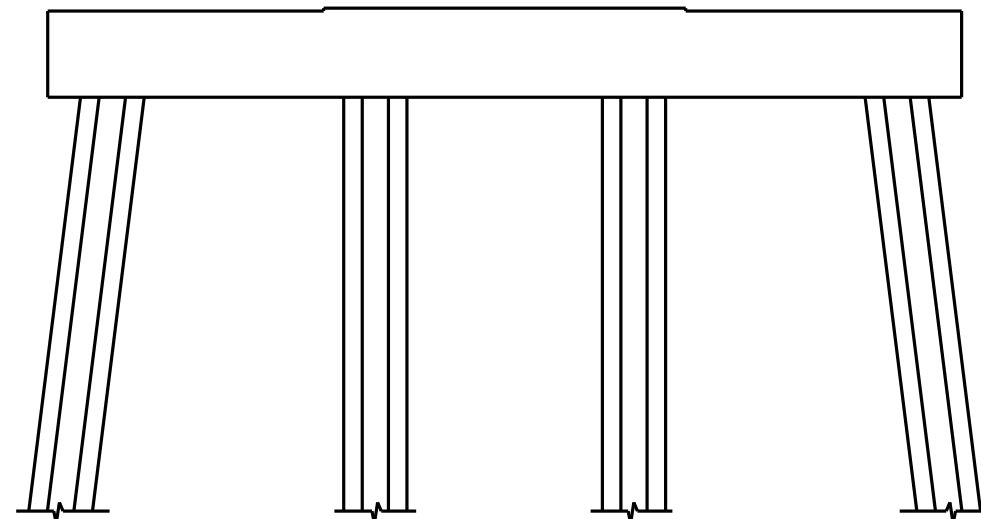

ELEVATION  
WEST SIDE

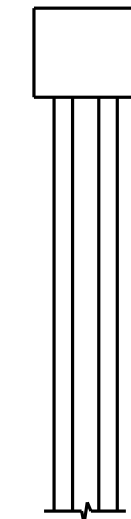

END VIEW  
SOUTH SIDE

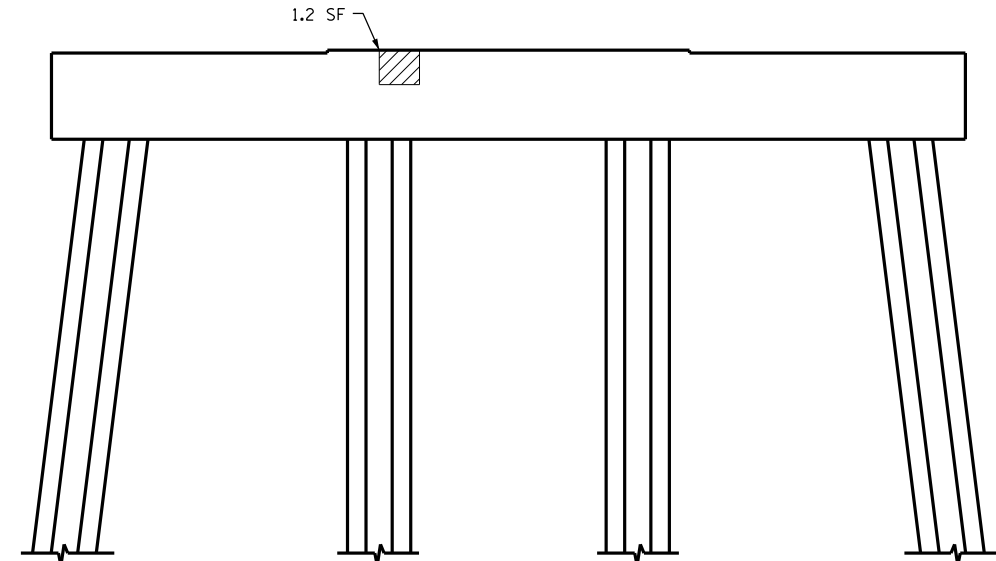

ELEVATION  
EAST SIDE

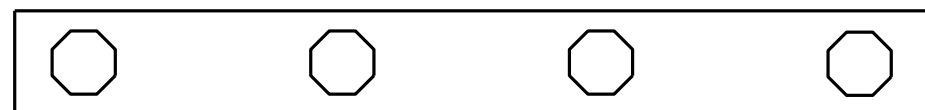

PLAN  
BOTTOM OF CAP

PROJECT NO. B-5936  
TYRRELL COUNTY  
 BRIDGE NO. 7

- SHOTCRETE REPAIR  
 - EPOXY RESIN INJECTION

DocuSigned by:  
*Paul Bryant* 10/2016  
 3653D2AF1B77448...



STATE OF NORTH CAROLINA  
 DEPARTMENT OF TRANSPORTATION  
 RALEIGH

**BENT 4**

DRAWN BY : P. D. BRYANT DATE : 4-2016  
 CHECKED BY : W. M. CLARKE DATE : 4-2016

DOCUMENT NOT CONSIDERED  
 FINAL UNLESS ALL  
 SIGNATURES COMPLETED

REVISIONS						SHEET NO.
NO.	BY:	DATE:	NO.	BY:	DATE:	
1			3			S-41
2			4			TOTAL SHEETS 394