

END ELEVATION
SHOWING PLACEMENT OF DOUBLE STIRRUPS AND LOCATION OF DOWEL HOLES. (STRAND LAYOUT NOT SHOWN.) INTERIOR SLAB UNIT SHOWN-EXTERIOR SLAB UNIT SIMILAR EXCEPT SHEAR KEY LOCATION.

TYPICAL SECTION

* - THE MAXIMUM PARAPET HEIGHTS, BARRIER RAIL HEIGHT AND CONCRETE WEARING SURFACE THICKNESS IS SHOWN. THE HEIGHT OF THE PARAPETS, BARRIER RAIL HEIGHT AND CONCRETE WEARING SURFACE THICKNESS VARIES WHILE THE TOP OF THE PARAPETS AND BARRIER RAIL FOLLOWS THE PROFILE OF THE GUTTERLINE. FOR CONCRETE PARAPET HEIGHT DETAILS AND CONCRETE WEARING SURFACE THICKNESS, SEE SHEET 8 OF 8. LAMP PEDESTALS NOT SHOWN FOR CLARITY. FOR LAMP PEDESTALS, SEE PARAPET SHEETS.

** FOR 4" Ø DUCT BANK, SEE "PROPOSED DUCT BANK" SHEETS.
† FOR ELECTRICAL CONDUIT, SEE "ELECTRICAL CONDUIT SYSTEM FOR LIGHTING" SHEET.

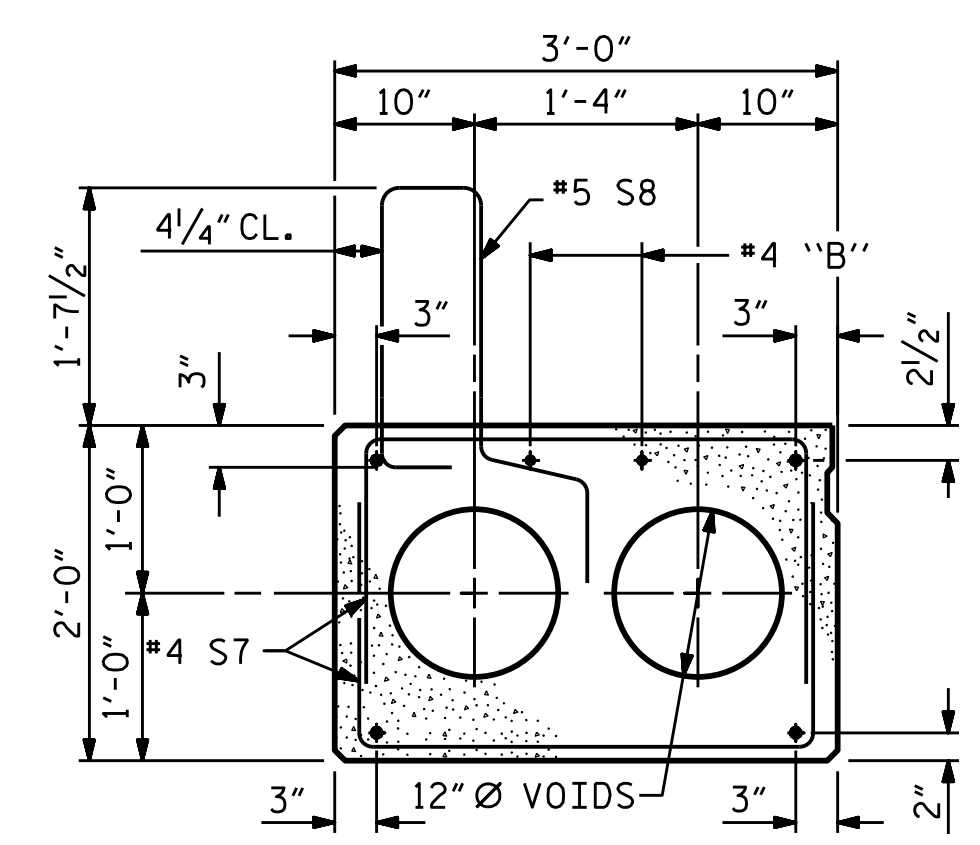

EXT. SLAB SECTION (TYPE I)
(FOR PRESTRESSED STRAND LAYOUT, SEE INTERIOR SLAB SECTION TYPE II)

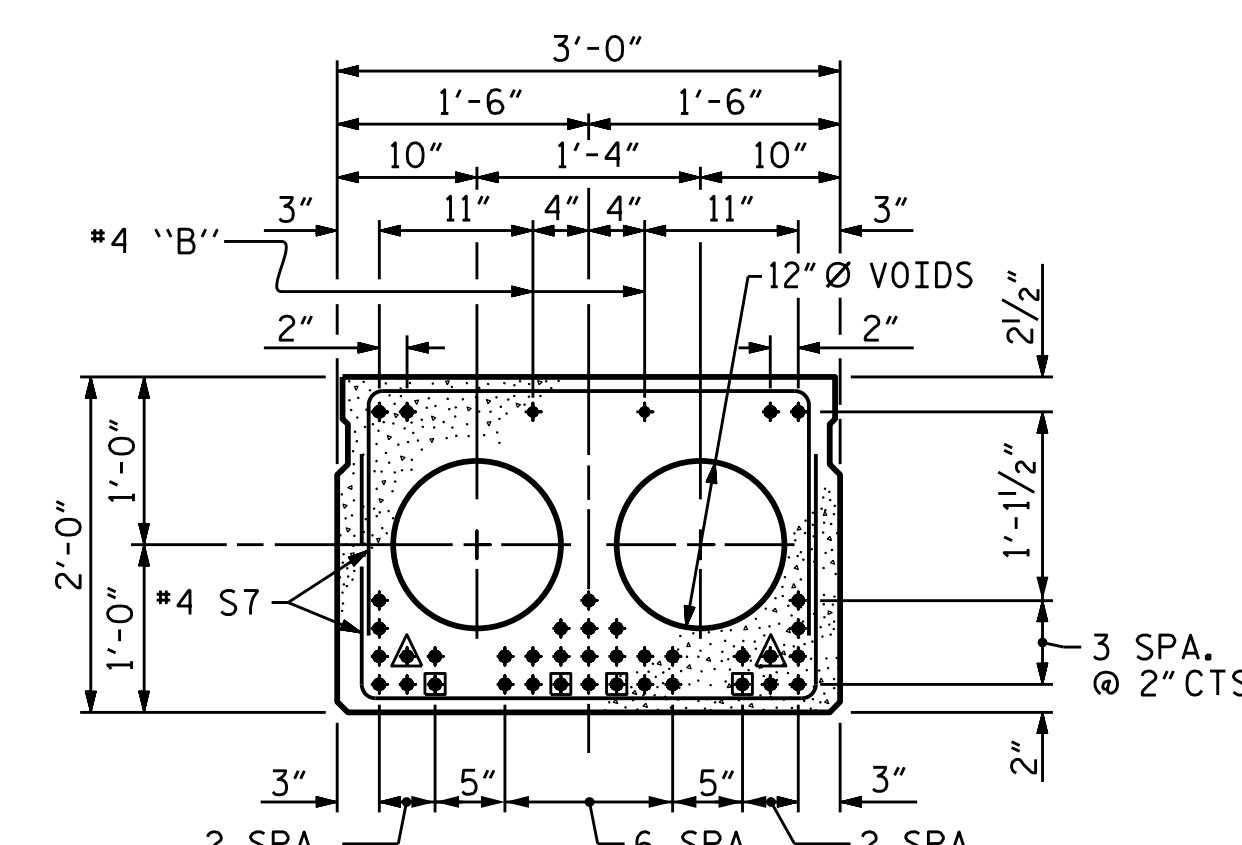

INTERIOR SLAB SECTION (TYPE II) (SPAN B & C)
(38 STRANDS REQUIRED)

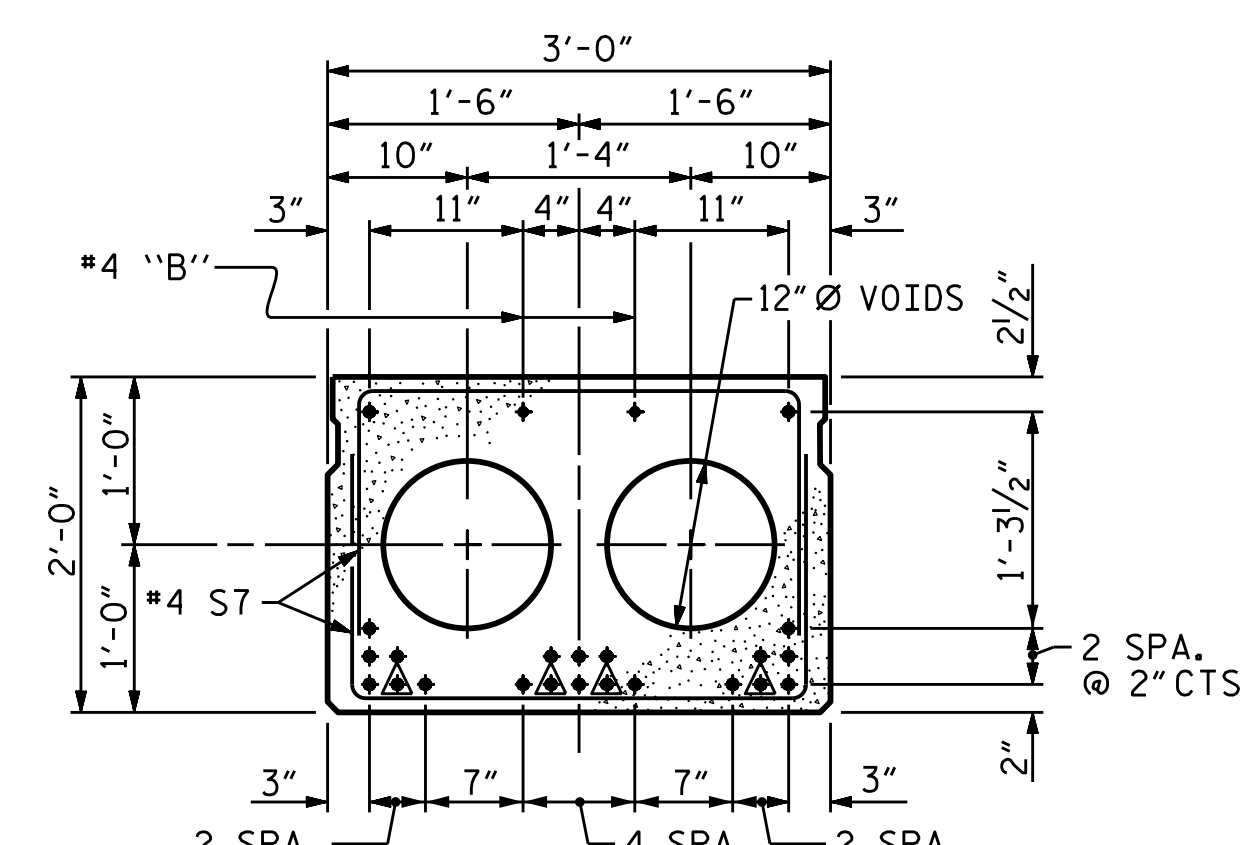

INTERIOR SLAB SECTION (TYPE II) (SPAN D)
(22 STRANDS REQUIRED)

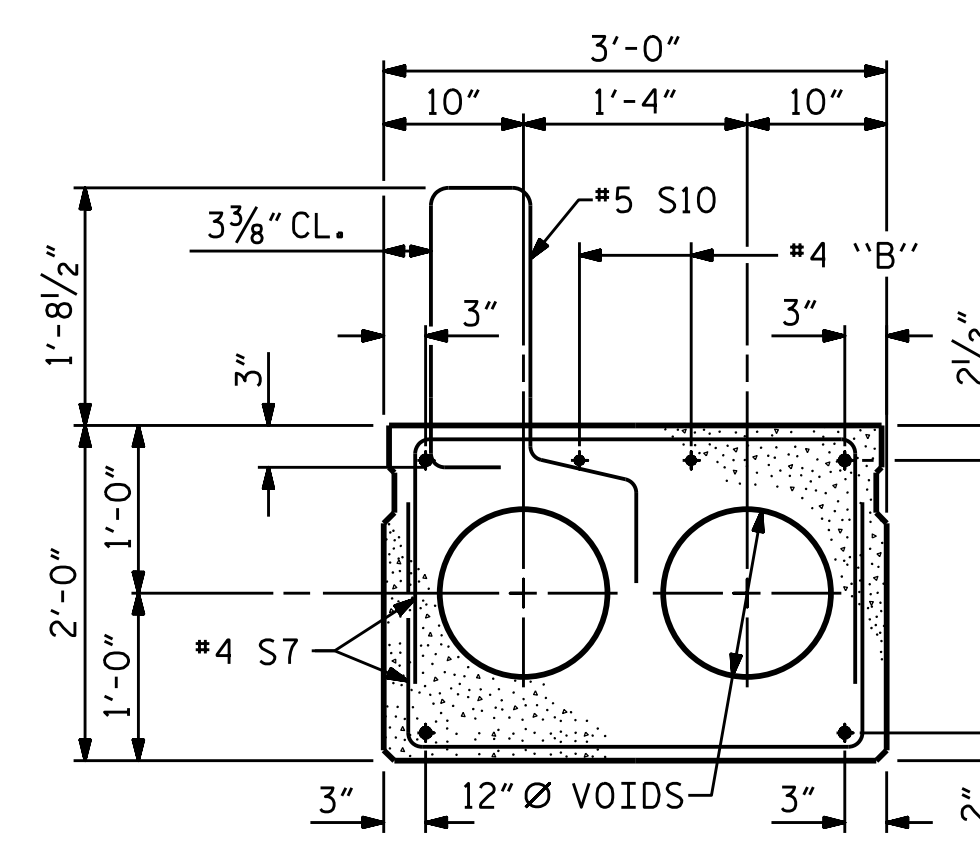

INT. SLAB SECTION (TYPE III)
(FOR PRESTRESSED STRAND LAYOUT, SEE INTERIOR SLAB SECTION TYPE II)

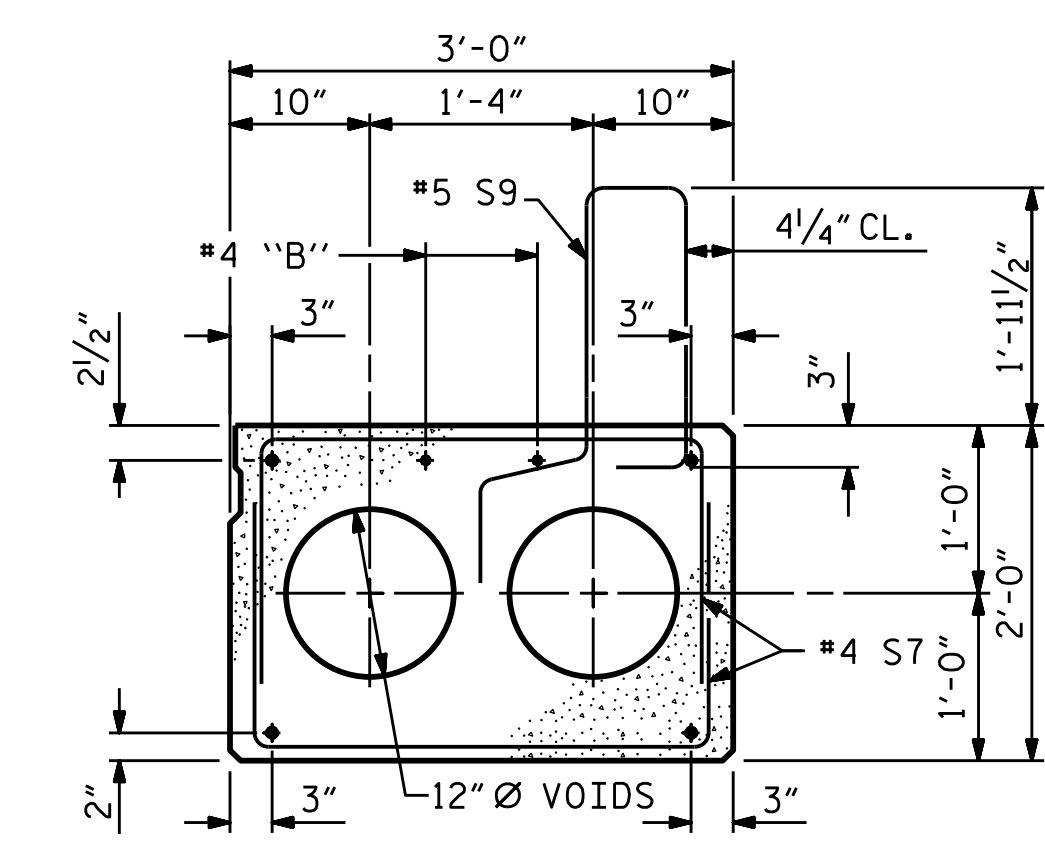

EXT. SLAB SECTION (TYPE IV)
(FOR PRESTRESSED STRAND LAYOUT, SEE INTERIOR SLAB SECTION TYPE II)

0.6" Ø LOW RELAXATION STRAND LAYOUT

- ▲ BOND SHALL BE BROKEN ON THESE STRANDS FOR A DISTANCE OF 10'-0" FROM END OF CORED SLAB UNIT. SEE STANDARD SPECIFICATIONS, ARTICLE 1078-7.
- BOND SHALL BE BROKEN ON THESE STRANDS FOR A DISTANCE OF 12'-0" FROM END OF CORED SLAB UNIT. SEE STANDARD SPECIFICATIONS, ARTICLE 1078-7.

DEBONDING LEGEND

PROJECT NO. B-5125
MACON COUNTY
STATION: 13+25.89 -L-

SHEET 2 OF 8
STATE OF NORTH CAROLINA
DEPARTMENT OF TRANSPORTATION
RALEIGH
3'-0" X 2'-0"
PRESTRESSED CONCRETE
CORED SLAB UNIT
90° SKEW
(SPAN B, C OR D)

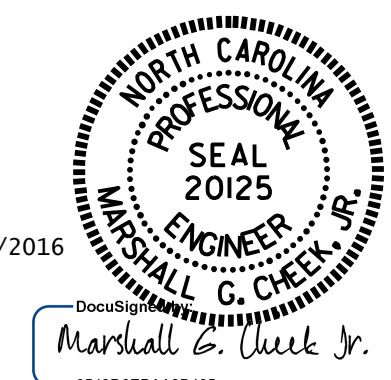

DRAWN BY: W.J. HARRIS DATE: 4/16
CHECKED BY: M.G. CHEEK DATE: 4/29/16
DESIGN ENGINEER OF RECORD: W.J. HARRIS DATE: 5/16

DOCUMENT NOT CONSIDERED FINAL UNLESS ALL SIGNATURES COMPLETED

REVISIONS				SHEET NO.	
NO.	BY:	DATE:	NO.	BY:	DATE:
1			3		
2			4		

TOTAL SHEETS: 43

*****SYTIME*****
*****DGN*****
*****USERNAME*****

STD. NO. 24PCS4_39_90S