

# BILL OF MATERIAL

## PHASE 1B C1-P1B

BAR	NO.	SIZE	TYPE	LENGTH	WEIGHT	BAR	NO.	SIZE	TYPE	LENGTH	WEIGHT
A1	177	#4	1	5'-8"	670	C1	72	#4	STR	26'-4"	1267
A2	177	#4	1	5'-4"	631						
A100	69	#5	STR	9'-0"	648	G1	2	#4	STR	12'-8"	17
A101	2	#5	STR	8'-1"	17	S1	6	#8	STR	12'-8"	203
A102	2	#5	STR	7'-0"	15	REINFORCING STEEL = 5,978 LBS.					
A103	2	#5	STR	5'-11"	12	FOR BAR TYPE DETAILS AND SPLICE LENGTH CHART, SEE SHEET 4 OF 6.					
A104	2	#5	STR	4'-10"	10						
A105	2	#5	STR	3'-9"	8						
A106	2	#5	STR	2'-8"	6						
A107	5	#5	STR	6'-1"	32						
A108	2	#5	STR	7'-9"	16						
A109	1	#5	STR	8'-9"	9						
A200	75	#6	STR	9'-0"	1014						
A201	2	#6	STR	8'-1"	24						
A202	2	#6	STR	7'-1"	21						
A203	2	#6	STR	6'-1"	18						
A204	2	#6	STR	5'-1"	15						
A205	2	#6	STR	4'-1"	12						
A206	2	#6	STR	3'-1"	9						
A207	2	#6	STR	2'-1"	6						
A208	5	#6	STR	5'-7"	42						
A209	2	#6	STR	7'-9"	23						
A210	1	#6	STR	8'-8"	13						
B1	89	#4	STR	7'-11"	471						
B2	177	#4	STR	6'-4"	749						

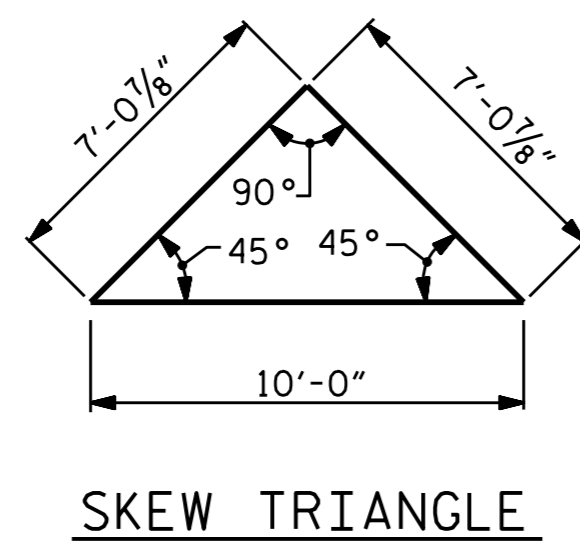

SKEW TRIANGLE

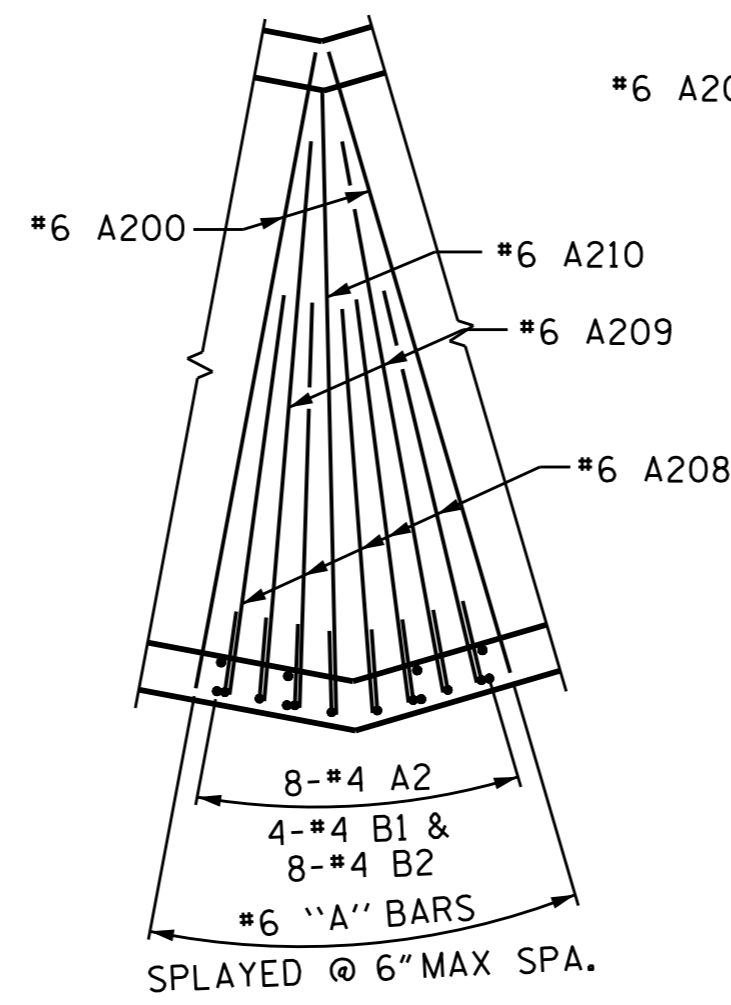

DETAIL A  
FLOOR SLAB

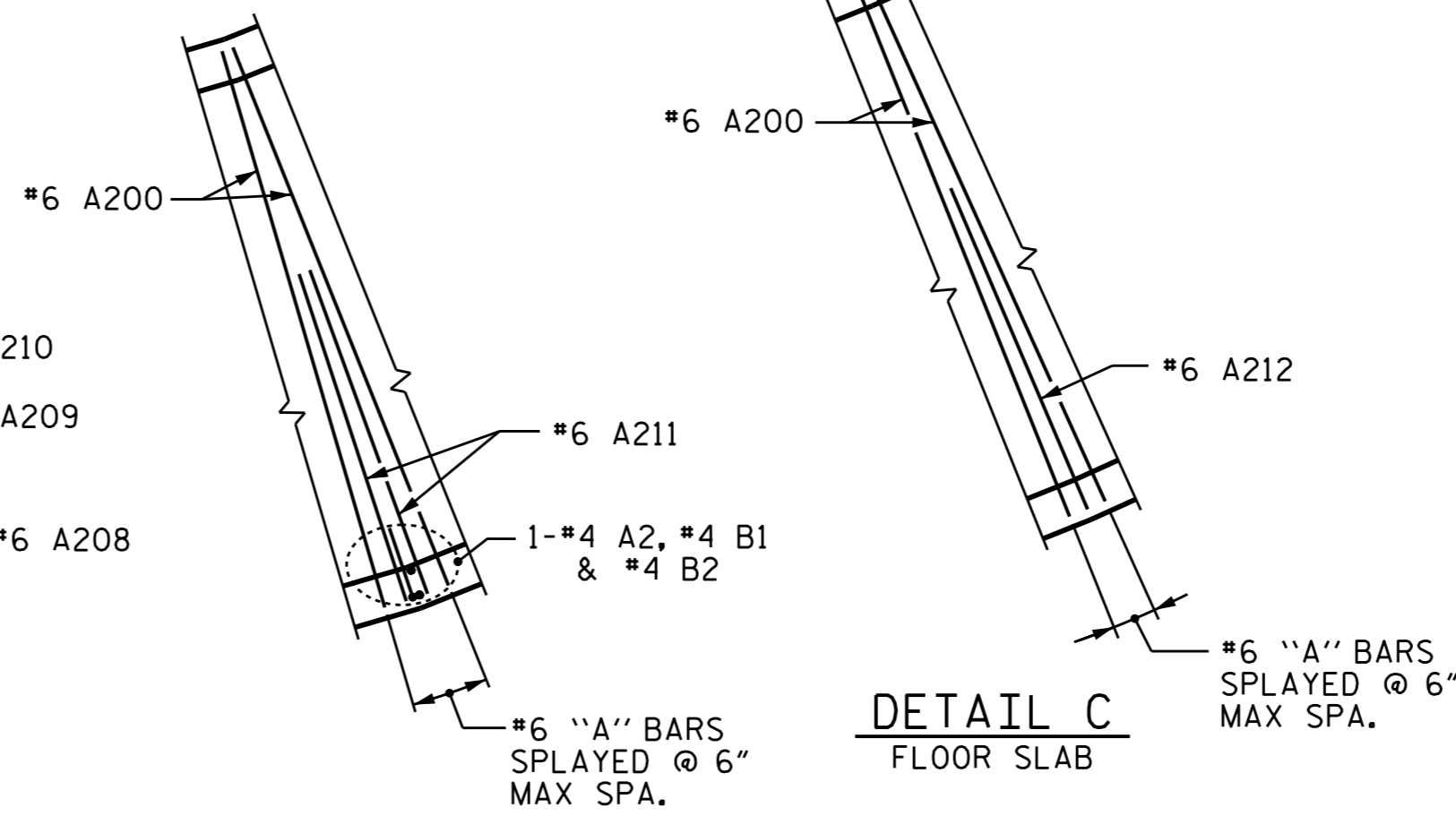

DETAIL B  
FLOOR SLAB

DETAIL C  
FLOOR SLAB

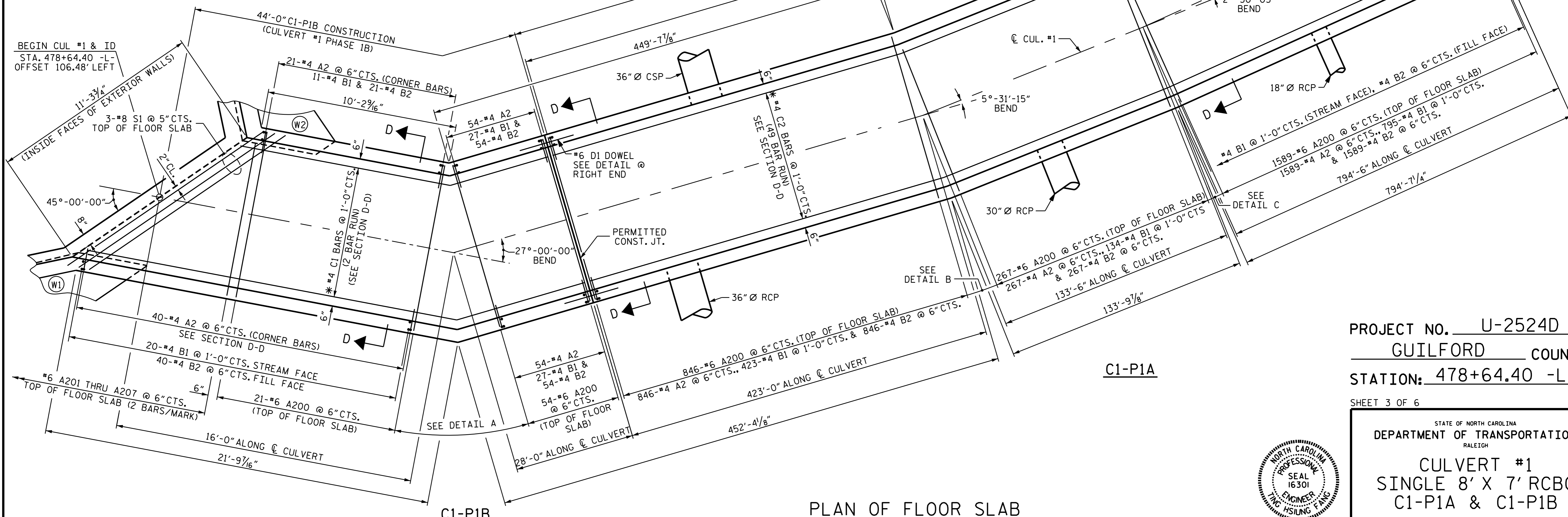

PLAN OF FLOOR SLAB

\* FIELD BEND "C" BARS AS NECESSARY.  
CONTRACTOR HAS AN OPTION TO CONSTRUCT  
C1-P1A AND C1-P1B IN ONE PHASE OR SEPARATELY.

PROJECT NO. U-2524D  
GUILFORD COUNTY  
 STATION: 478+64.40 -L-

SHEET 3 OF 6



STATE OF NORTH CAROLINA  
 DEPARTMENT OF TRANSPORTATION  
 RALEIGH  
**CULVERT #1**  
**SINGLE 8' X 7' RCBC**  
**C1-P1A & C1-P1B**  
 FLOOR SLAB DETAILS

DRAWN BY: A. SORSENGINH DATE: 1/2016  
 CHECKED BY: T. H. FANG DATE: 5/15/16  
 DESIGN ENGINEER OF RECORD: A. SORSENGINH DATE: 5/26/16

DocuSigned by:  
Ting Fang  
 E72088400977435

REVISIONS						SHEET NO. C-3
NO.	BY:	DATE:	NO.	BY:	DATE:	
1			3			TOTAL SHEETS 34
2			4			