

PROJECT REFERENCE NO.	SHEET NO.
U-2524D	EC-18/CONST.4
RW SHEET NO.	
ROADWAY DESIGN ENGINEER	HYDRAULICS ENGINEER

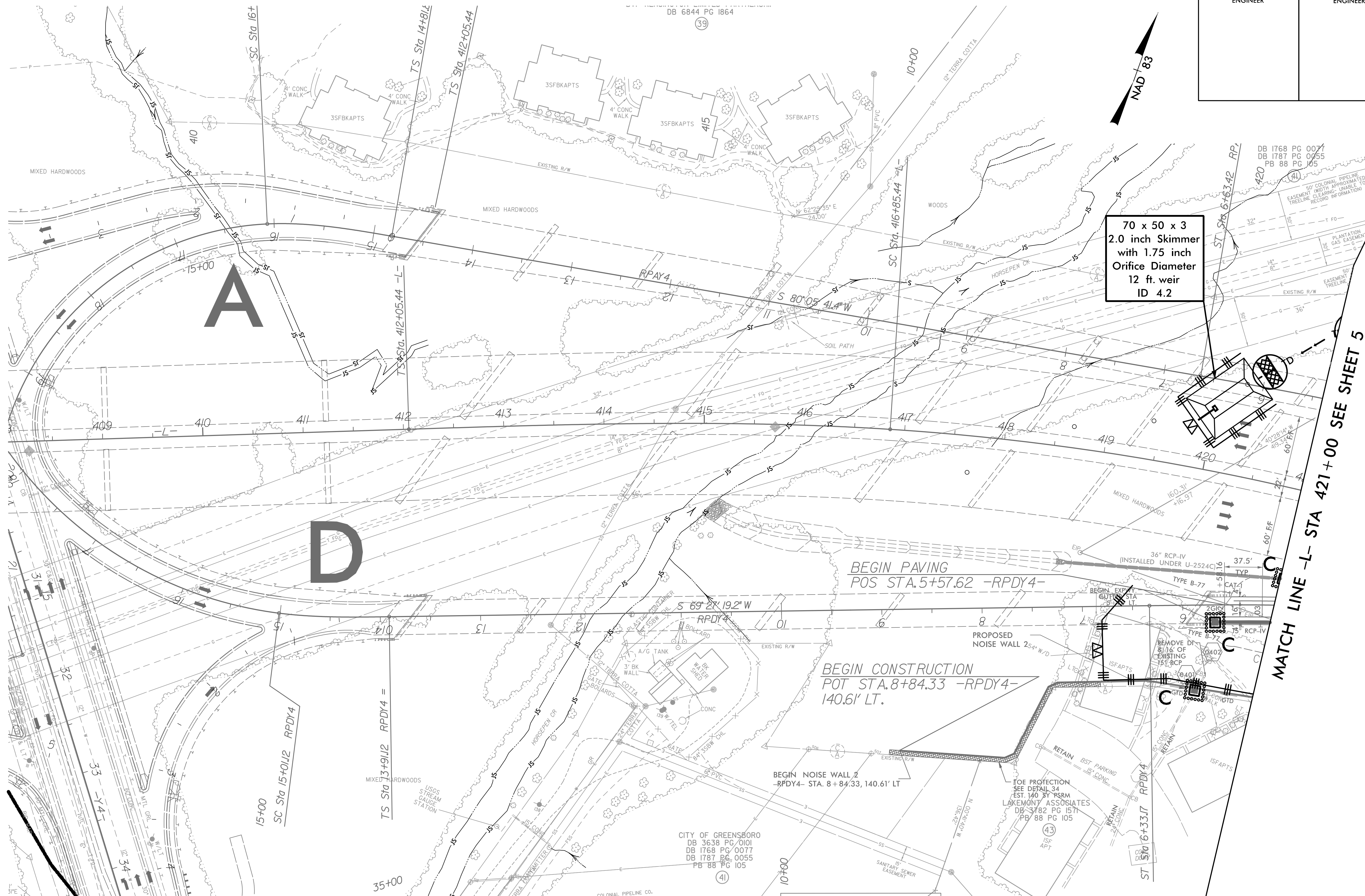

UTILIZE FABRIC INSERT INLET PROTECTION DEVICE IN LIEU OF ROCK INLET SEDIMENT TRAP TYPE 'C' TO AVOID IMPOUNDING RUNOFF ON ROADWAY OPEN TO PUBLIC AND AS DIRECTED.

NOTE:  
SEE SHEET 2B-2 CURVE DATA  
SEE SHEET 15 FOR -L- PROFILE

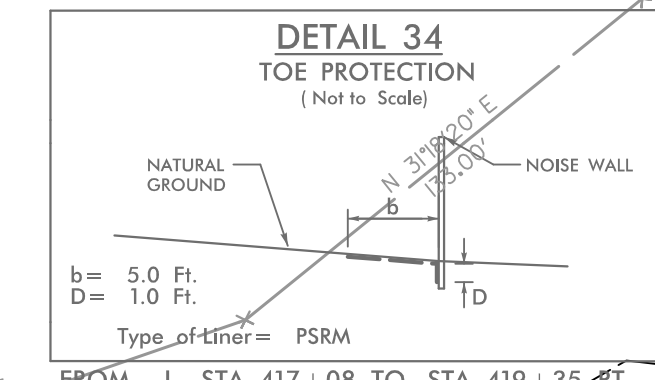

NOTE:  
SEE SHEET 2B-2 CURVE DATA  
SEE SHEET 15 FOR -L- PROFILE  
SEE SHEET 23 FOR RPY4 PROFILE  
SEE SHEET 23 FOR RPDY4 PROFILE