

EDI MODEL 2010ECL-NC CONFLICT MONITOR PROGRAMMING DETAIL

(remove jumpers and set switches as shown)

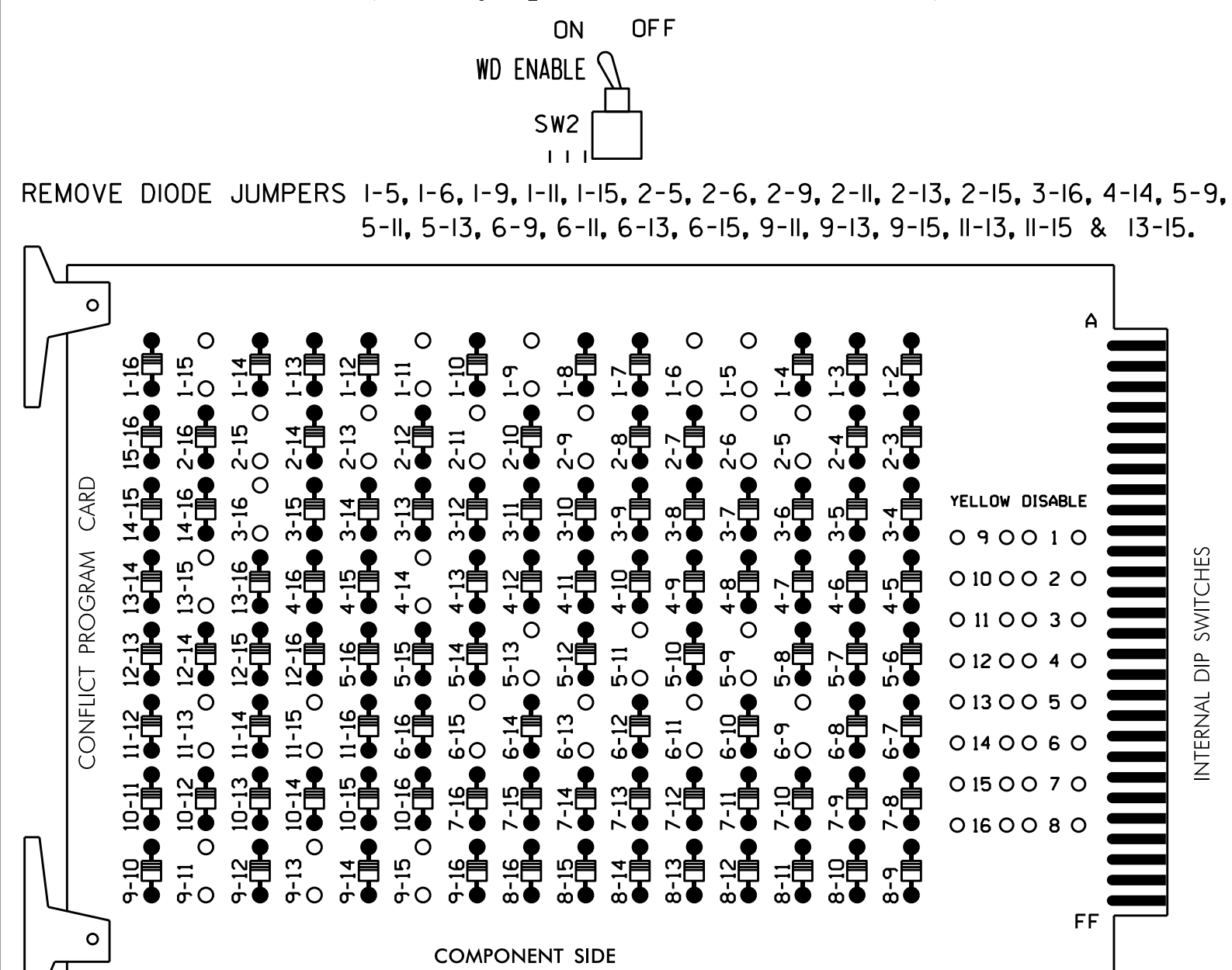

REMOVE JUMPERS AS SHOWN

NOTES:

- Card is provided with all diode jumpers in place. Removal of any jumper allows its channels to run concurrently.
- Make sure jumpers SEL2-SEL5 are present on the monitor board.

■ = DENOTES POSITION OF SWITCH

NOTES

- To prevent "flash-conflict" problems, insert red flash program blocks for all unused vehicle load switches in the output file. The installer shall verify that signal heads flash in accordance with the Signal Plans.
- Ensure that Red Enable is active at all times during normal operation. To prevent Red Failures on unused monitor channels, tie unused red monitor inputs 5,7,8 10,12,13,14,15 & 16 to load switch AC+ per the cabinet manufacturer's instructions.
- Enable Simultaneous Gap-Out for all phases.
- Program phases 2 and 6 for Start Up In Green.
- Program phases 2, 3, 4 and 6 for 'STARTUP PED CALL'.
- Program phases 2 and 6 for Yellow Flash and overlap 1 as Wag Overlaps.
- The cabinet and controller are part of the Fayetteville City System.

EQUIPMENT INFORMATION

CONTROLLER.....2070L
 CABINET.....332 /W/ AUX
 SOFTWARE.....ECONOLITE OASIS
 CABINET MOUNT.....BASE
 OUTPUT FILE POSITIONS...18 WITH AUX. OUTPUT FILE
 LOAD SWITCHES USED.....S1,S2,S2P,S3,S4,S4P,S5,S6,S6P,S8P,S9,S12.
 PHASES USED.....1,2,3,4,5,6,2PED,3PED,4PED,6PED.
 OVERLAP "A".....1+2
 OVERLAP "B".....NOT USED
 OVERLAP "C".....5+6
 OVERLAP "D".....NOT USED

SIGNAL HEAD HOOK-UP CHART

LOAD SWITCH NO.	S1	S2	S2P	S3	S4	S4P	S5	S6	S6P	S7	S8	S8P	S9	S10	S11	S12	S13	S14					
PHASE	1	2	2 PED	3	4	4 PED	5	6	6 PED	7	8	3 PED	OLA	OLB	SPARE	OLC	OLD	SPARE					
SIGNAL HEAD NO.	11	33	21,22	P21, P22	31	32	33	41	42	P41, P42	51	61,62	P61, P62	NU	NU	P31, P32	11	NU	NU	51	NU	NU	
RED	*	128		116	116	101	101				134												
YELLOW		129		117	117	102	102	*	135														
GREEN		130		118	118	103	103				136												
RED ARROW				116																			
YELLOW ARROW	126			117																			
FLASHING YELLOW ARROW																							
GREEN ARROW	127	127		118	118	103			133														
Hand icon				113					104				119										
Person icon				115					106				121										

NU = Not Used

* Denotes install load resistor. See load resistor installation detail this sheet.

★ See pictorial of head wiring in detail below.

INPUT FILE POSITION LAYOUT

(front view)

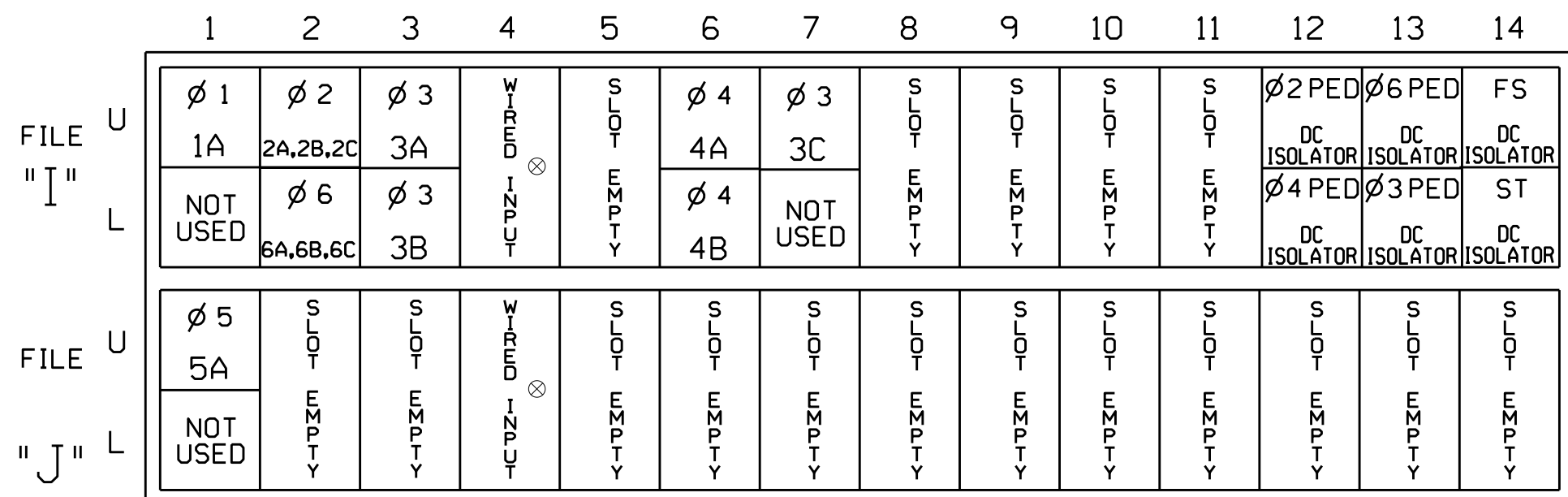

EX.: 1A, 2A, ETC. = LOOP NO.'S

FS = FLASH SENSE
 ST = STOP TIME

⊗ Wired Input - Do not populate slot with detector card

INPUT FILE CONNECTION & PROGRAMMING CHART

LOOP NO.	LOOP TERMINAL	INPUT FILE POS.	PIN NO.	INPUT ASSIGNMENT NO.	DETECTOR NO.	NEMA PHASE	CALL	EXTEND	FULL TIME DELAY	STRETCH TIME	DELAY TIME
1A ¹	TB2-1,2	I1U	56	18	1	1	Y	Y			15
	-	J4U	48	10	26	6	Y	Y			
2A,2B,2C	TB2-5,6	I2U	39	1	2	2	Y	Y			
3A	TB2-9,10	I3U	63	25	32	3	Y	Y			3
3B	TB2-11,12	I3L	76	38	42	3	Y	Y			
3C	TB6-1,2	I7U	65	27	34	3	Y	Y			15
4A	TB4-9,10	I6U	41	3	4	4	Y	Y			3
4B	TB4-11,12	I6L	45	7	14	4	Y	Y			10
5A ²	TB3-1,2	J1U	55	17	5	5	Y	Y			15
	-	I4U	47	9	22	2	Y	Y			
6A,6B,6C	TB2-7,8	I2L	43	5	12	6	Y	Y			
PED PUSH BUTTONS											
P21,P22	TB8-4,6	I12U	67	29	PED 2	2	PED				
P41,P42	TB8-5,6	I12L	69	31	PED 4	4	PED				
P61,P62	TB8-7,9	I13U	68	30	PED 6	6	PED				
P31,P32	TB8-8,9	I13L	70	32	PED 8	3	PED				

NOTE:
 INSTALL DC ISOLATORS IN INPUT FILE SLOTS 112 AND 113.

- Add jumper from I1-W to J4-W, on rear of input file.
- Add jumper from J1-W to I4-W, on rear of input file.

INPUT FILE POSITION LEGEND: J2L

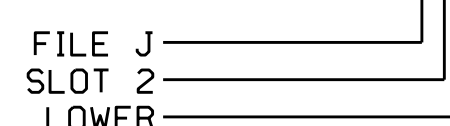

PED 3 PROGRAMMING DETAIL

(program controller as shown below)

CHANGING OUTPUT ASSIGNMENTS

- FROM MAIN MENU SELECT '6' (OUTPUTS), THEN '1' (OUTPUT ASSIGNMENTS)
- ENTER 17 (PHASE 8 DW) FOR OUTPUT ASSIGNMENT #.
- SCROLL DOWN TO 'PEDESTRIAN PHASE' AND ENTER 'Y' REGARDLESS OF DEFAULT PROGRAMMING
- ENTER '3' FOR 'SELECT PEDESTRIAN PHASE'. NO CHANGE NEEDED FOR 'SELECT COLOR'
- BACKUP TO 'OUTPUT ASSIGNMENTS AND SETTINGS MENU:' BY PRESSING THE 'ESC' BUTTON ON KEYBOARD.
- SELECT '1' (OUTPUT ASSIGNMENTS)
- ENTER 18 (PHASE 8 W) FOR OUTPUT ASSIGNMENT #.
- REPEAT STEPS # 3 AND # 4.

CHANGING INPUT ASSIGNMENTS

- FROM MAIN MENU SELECT '7' (DETECTORS), THEN '2' (PEDESTRIAN DETECTOR ASSIGNMENTS)
- CYCLE TO PED DETECTOR #8 BY REPEATEDLY DEPRESSING '+' KEY
- MODIFY PHASE ASSIGNED TO PED DETECTOR # 8 FROM PHASE 8 TO PHASE 3

PROGRAMMING COMPLETE

THIS ELECTRICAL DETAIL IS FOR THE SIGNAL DESIGN: 06-0039
 DESIGNED: July 2015
 SEALED: 8/26/15
 REVISED: N/A

FYA SIGNAL WIRING DETAIL

(wire signal heads as shown)

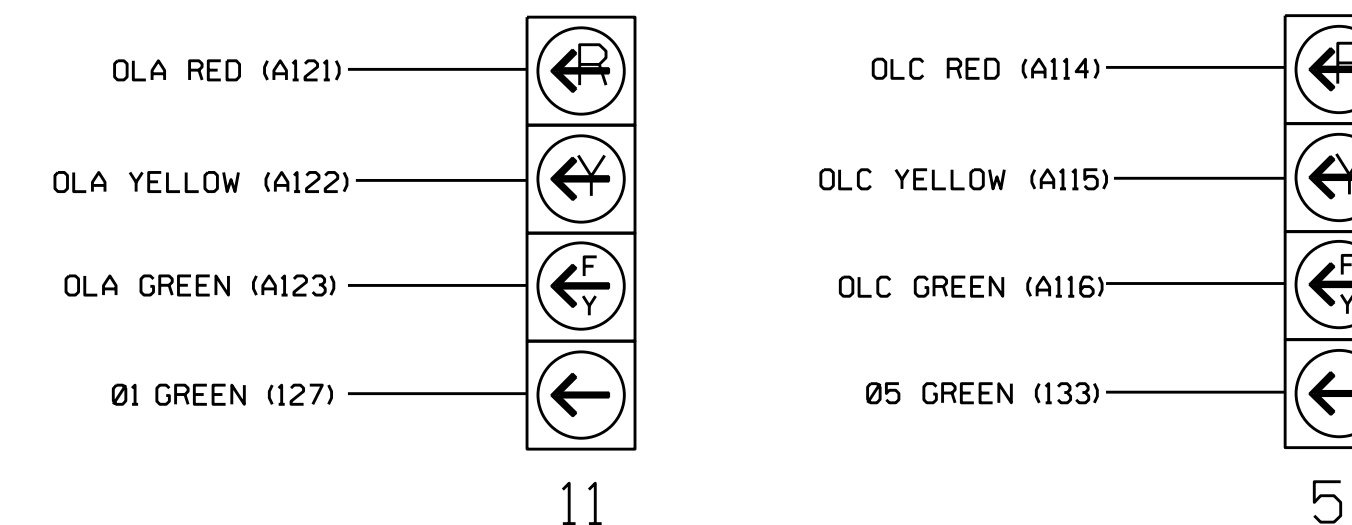

NOTE

The sequence display for these signal heads require special logic programming. See sheet 2 for programming instructions.

LOAD RESISTOR INSTALLATION DETAIL

(install resistors as shown below)

VALUE (ohms)	WATTAGE
1.5K - 1.9K	25W (min)
2.0K - 3.0K	10W (min)

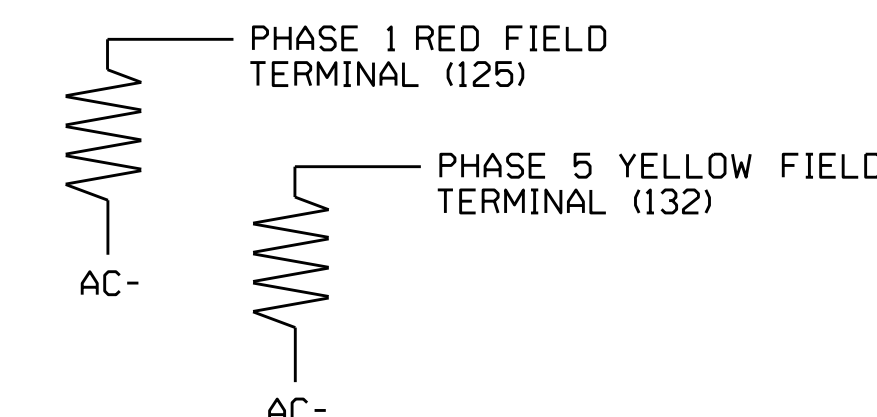

Electrical Detail - Sheet 1 of 2 - Final

ELECTRICAL AND PROGRAMMING DETAILS FOR: Prepared in the Offices of: 750 N. Greenfield Pkwy, Garner, NC 27529	NC 24-210 (Rowan Street) at Ray Avenue		SEAL GEORGE C. BROWN ENGINEER
	Division 6 PLAN DATE: July 2015 PREPARED BY: B. Simmons	Cumberland County REVIEWED BY: REVIEWED BY:	