

SECTION A-A

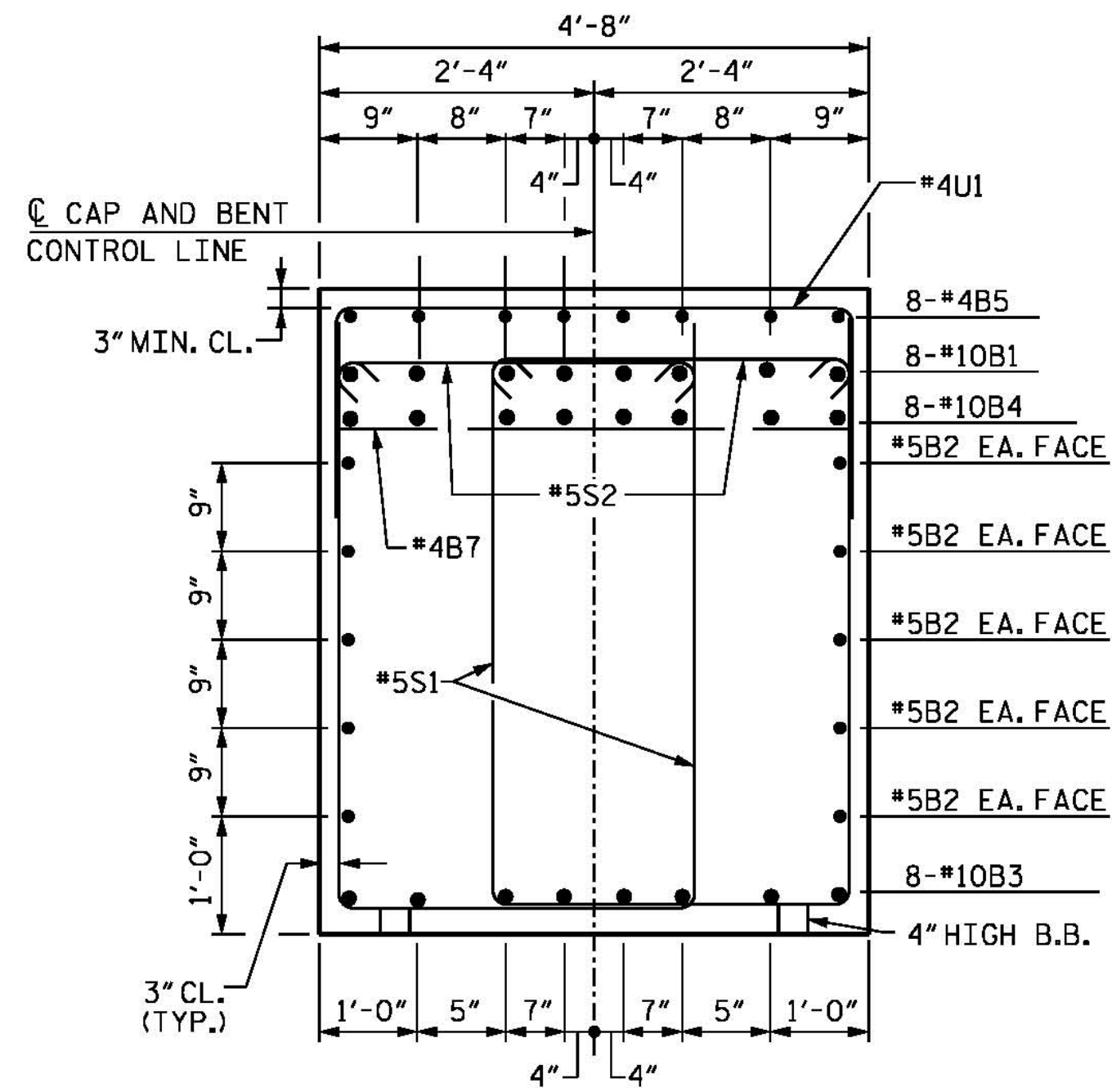

SECTION B-B

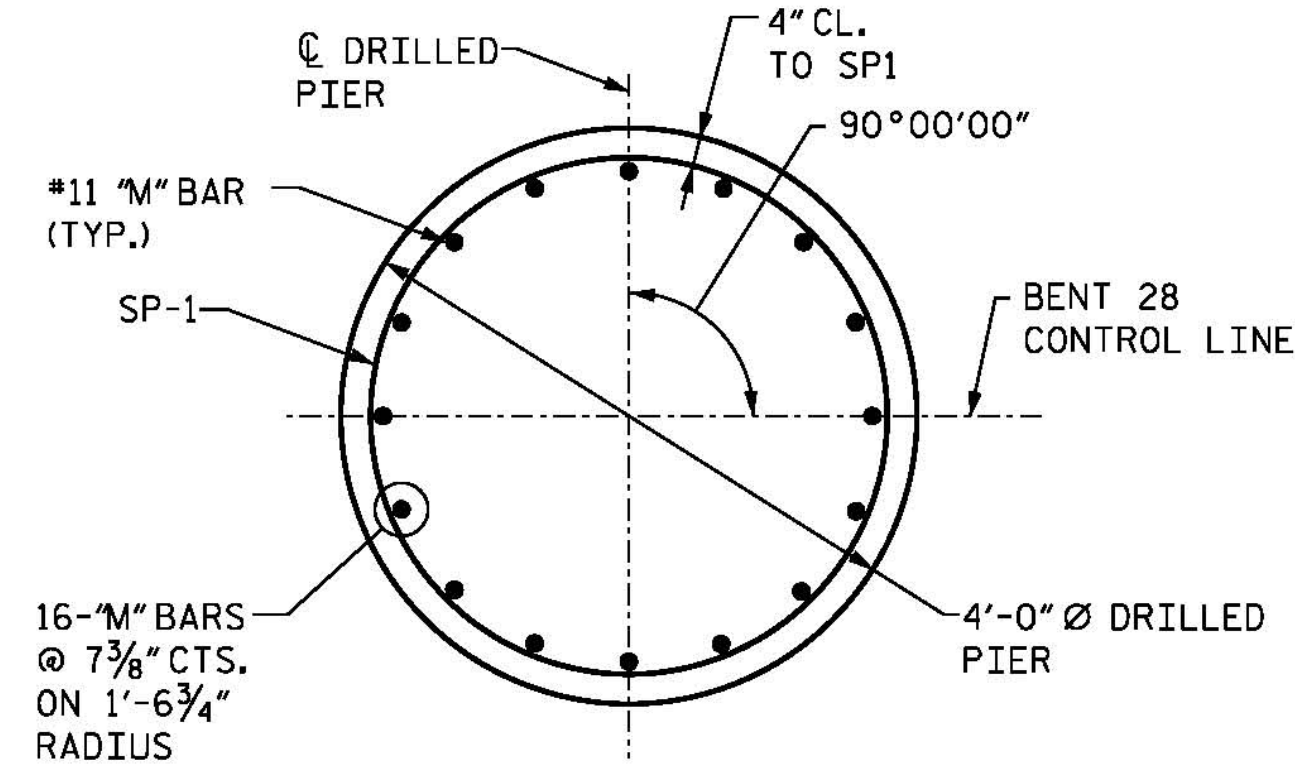

DRILLED PIER DETAIL

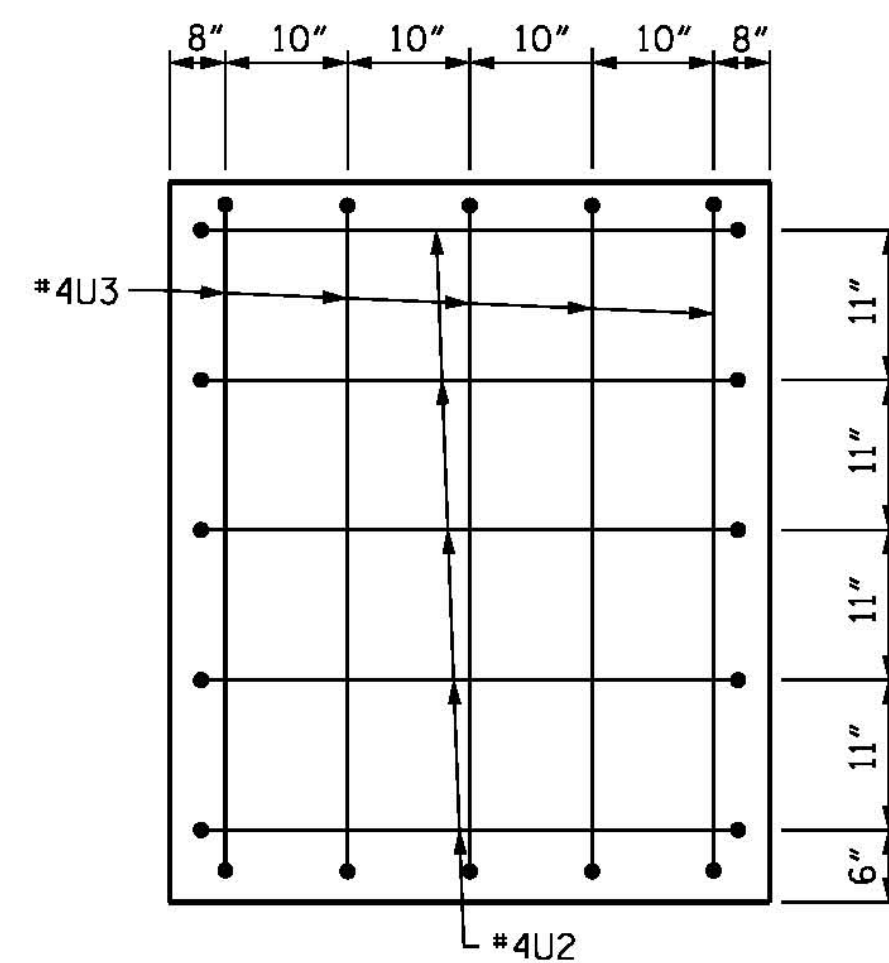

VIEW X-X

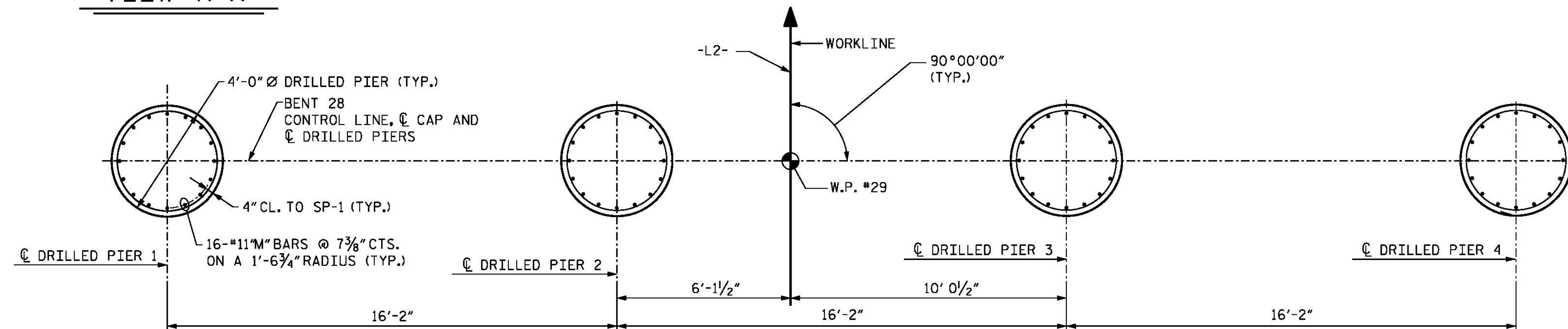

PLAN OF DRILLED PIERS

(REINFORCING STEEL ARE TYPICAL FOR EACH DRILLED PIER)

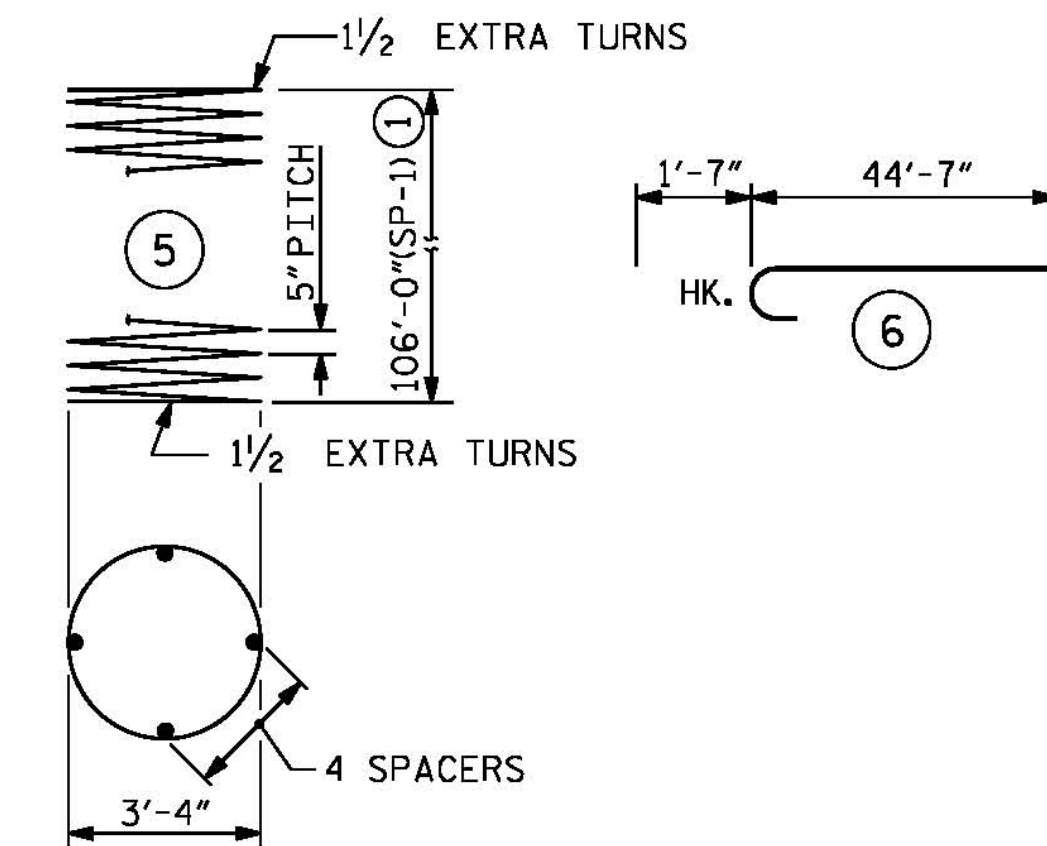
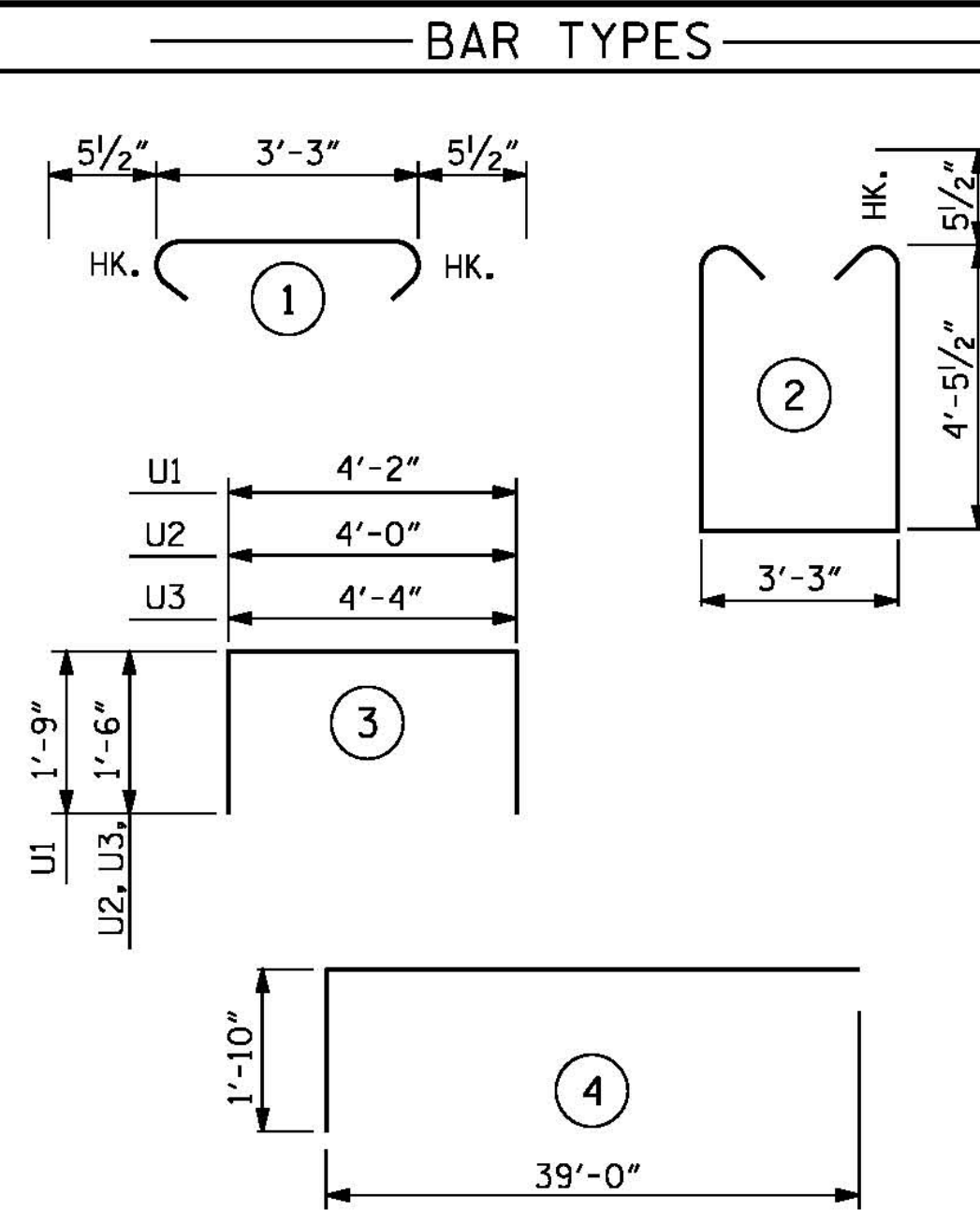

ALL BAR DIMENSIONS ARE OUT TO OUT.

* THE SP-1 EPOXY COATED SPIRAL REINFORCING STEEL SHALL BE W31 OR D-31 COLD DRAWN WIRE OR #5 PLAIN OR DEFORMED BAR,

① CONTRACTOR MAY PROVIDE 3'-0" MIN. SPLICE AT MID HEIGHT OF EPOXY COATED SPIRAL REINFORCING STEEL. NO ADDITIONAL PAYMENT WILL BE PROVIDED FOR SPLICES.

BILL OF MATERIAL

BENT 28

BAR	NUMBER	SIZE	TYPE	LENGTH	WEIGHT
B1	16	#10	4	40'-10"	2811
B2	20	#5	STR	33'-11"	708
B3	16	#10	STR	38'-1"	2622
B4	16	#10	STR	39'-0"	2685
B5	16	#4	STR	23'-2"	248
B6	16	#4	STR	3'-6"	37
B7	16	#4	STR	4'-2"	45
M1	64	#11	6	46'-2"	15,698
M2	128	#11	STR	44'-7"	30,320
S1	246	#5	3	13'-1"	3357
S2	246	#5	1	4'-2"	1069
U1	65	#4	4	7'-8"	333
U2	10	#4	4	7'-0"	47
U3	10	#4	4	7'-4"	49

EPOXY COATED REINFORCING STEEL LBS. 60,027

EPOXY COATED SPIRAL COLUMN REINFORCING STEEL LBS. 11,062

CLASS "AA" CONCRETE BREAKDOWN
POUR #2 - CAP 59.2 C.Y.
CLASS "AA" CONCRETE 59.2 C.Y.

DRILLED PIER QUANTITIES

POUR #1 - DRILLED PIER CONCRETE	198.2 C.Y.
4'-0" DRILLED PIERS	425.8 L.F.
PERMANENT STEEL CASING FOR 4'-0" DRILLED PIERS	69.8 L.F.
SPT TESTING	4 EA.
SID INSPECTIONS	1 EA.
CSL TUBES	1728 L.F.

PROJECT NO. B-4929

PENDER COUNTY

STATION: 38+13.81 -L2-

SHEET 2 OF 2

STATE OF NORTH CAROLINA
DEPARTMENT OF TRANSPORTATION
RALEIGH

SUBSTRUCTURE

BENT 28

SECTIONS AND DETAILS

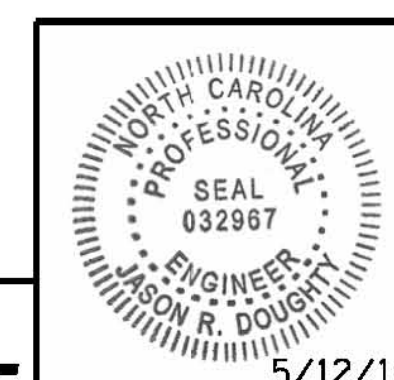

PARSONS BRINCKERHOFF
434 FAYETTEVILLE STREET
SUITE 1500
RALEIGH, NC 27601
LICENSE NO. F-0165

DocuSigned by:
Jason R. Doughty
00F1C86448274F7...

REVISIONS

NO.	BY:	DATE:	NO.	BY:	DATE:
1			3		
2			4		

SHEET NO.
S-201
TOTAL SHEETS
278

DOCUMENT NOT CONSIDERED FINAL
UNLESS ALL SIGNATURES COMPLETED

5/11/2016
400_395_B4929_SMU_IB282.dgn

DESIGNED BY: MJW/AMD DATE: JAN. 2016
DRAWN BY: B. CALDWELL DATE: FEB. 2016
CHECKED BY: J. SHERMAN DATE: MAR. 2016
DESIGN ENGINEER OF RECORD: J. DOUGHTY DATE: MAY 2016