

**This electronic collection of documents is provided  
for the convenience of the user  
and is Not a Certified Document –**

**The documents contained herein were originally issued  
and sealed by the individuals whose names and license  
numbers appear on each page, on the dates appearing  
with their signature on that page.**

**This file or an individual page  
shall not be considered a certified document.**

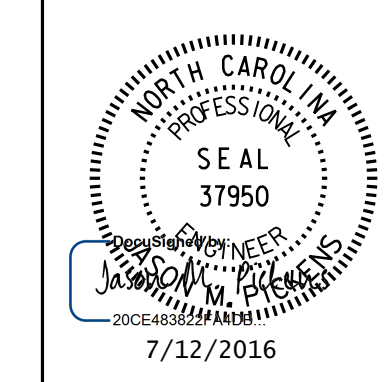

**DOCUMENT NOT CONSIDERED FINAL  
UNLESS ALL SIGNATURES COMPLETED**

**STATE OF NORTH CAROLINA  
DEPARTMENT OF TRANSPORTATION**

**PAVEMENT MARKING PLAN**

**NEW HANOVER COUNTY**

**LOCATION: WILMINGTON - NC 132 (COLLEGE ROAD) AT HOGGARD  
DRIVE /HURST DRIVE**

**INDEX**

<u>SHEET NO.</u>	<u>DESCRIPTION</u>
PMP-1	PAVEMENT MARKING PLAN TITLE SHEET
PMP-1A	FINAL PAVEMENT MARKING SCHEDULE & LEGEND
PMP-1B	CROSSWALK PAVEMENT MARKING GUIDANCE DETAIL
PMP-1C	REVISED PAVEMENT MARKING ROADWAY STANDARD DETAIL
PMP-2 THRU PMP-3	FINAL PAVEMENT MARKING PLANS

**ROADWAY STANDARD DRAWING**

THE FOLLOWING ROADWAY STANDARDS AS APPEAR IN "ROADWAY STANDARD DRAWINGS" - PROJECT SERVICES UNIT - N.C. DEPARTMENT OF TRANSPORTATION - RALEIGH, N.C., DATED JANUARY 2012 ARE APPLICABLE TO THIS PROJECT AND BY REFERENCE HEREBY ARE CONSIDERED A PART OF THESE PLANS:

<u>STD. NO.</u>	<u>TITLE</u>
1205.01	PAVEMENT MARKINGS - LINE TYPES AND OFFSETS
1205.02	PAVEMENT MARKINGS - 2 LANE AND MULTILANE ROADWAYS
1205.04	PAVEMENT MARKINGS - INTERSECTIONS
1205.05	PAVEMENT MARKINGS - TURN LANES
1205.06	PAVEMENT MARKINGS - LANE DROPS
1205.08	PAVEMENT MARKINGS - SYMBOL AND WORD MESSAGES
1205.09	PAVEMENT MARKINGS - PAINTED ISLANDS
1250.01	RAISED PAVEMENT MARKERS - INSTALLATION SPACING
1251.01	RAISED PAVEMENT MARKERS - TEMPORARY AND PERMANENT
1253.01	RAISED PAVEMENT MARKERS - SNOWPLOWABLE

**GENERAL NOTES**

THE FOLLOWING GENERAL NOTES APPLY AT ALL TIMES FOR THE DURATION OF THE CONSTRUCTION PROJECT, EXCEPT WHEN OTHERWISE NOTED IN THE PLAN, OR DIRECTED BY THE ENGINEER.

- A) INSTALL PAVEMENT MARKINGS AND PAVEMENT MARKERS ON THE FINAL SURFACE AS FOLLOWS:

<u>ROAD NAME</u>	<u>MARKING</u>	<u>MARKER</u>
-L- (NC 132)	THERMOPLASTIC	SNOWPLOWABLE
-Y- LINES	THERMOPLASTIC	RAISED

- B) TIE PROPOSED PAVEMENT MARKING LINES TO EXISTING PAVEMENT MARKING LINES.  
 C) REMOVE/REPLACE ANY CONFLICTING/DAMAGED PAVEMENT MARKINGS AND MARKERS.  
 D) STOP BAR LOCATION AT NON-SIGNALIZED INTERSECTIONS MAY BE ADJUSTED AS DIRECTED BY THE ENGINEER.  
 E) UNLESS OTHERWISE SPECIFIED, HEATED-IN-PLACE THERMOPLASTIC MAY BE USED IN LIEU OF EXTRUDED THERMOPLASTIC FOR STOP BARS, SYMBOLS, CHARACTERS AND DIAGONALS. IF HEATED-IN-PLACE IS USED, IT SHALL BE PAID FOR USING THE EXTRUDED THERMOPLASTIC PAY ITEM.  
 F) ALL PAVEMENT MARKING PAY ITEMS ARE PAID FOR UNDER 2017CPT.03.01.10651 (SEE PART III).

**PLANS PREPARED BY:**

**DAVID L. WILVER, P.E.** PROJECT ENGINEER  
**J. MATTHEW PICKENS, P.E.** PROJECT DESIGN ENGINEER

**PLANS PREPARED BY :**

**PARSONS**  
 NC LICENSE NO. F-0246  
 FOR  
 DIVISION OF HIGHWAYS

**T.I.P.: W-5203AA**



**CONTRACT: C203888**

### FINAL PAVEMENT MARKING SCHEDULE

SYMBOL	DESCRIPTION	PAVEMENT MARKINGS
THERMOPLASTIC (24", 120 MILS)		
T2	WHITE STOPBAR	
T3	WHITE CROSSWALK LINE	
THERMOPLASTIC (12", 90 MILS)		
TU	WHITE DIAGONAL	
THERMOPLASTIC (12", 120 MILS)		
TT	WHITE SOLID LANE LINE	
THERMOPLASTIC (8", 90 MILS)		
TN	WHITE GORELINE	
THERMOPLASTIC (8", 120 MILS)		
T13	3'-9"/SP WHITE MINISKIP	
TR	WHITE SOLID LANE LINE	
THERMOPLASTIC (4", 90 MILS)		
TA	WHITE EDGELINE	
TB	YELLOW EDGELINE	
THERMOPLASTIC (4", 120 MILS)		
TC	10' WHITE SKIP	
TD	3'-9"/SP WHITE MINISKIP	
TE	WHITE SOLID LANE LINE	
TI	YELLOW DOUBLE CENTER LINE	
THERMOPLASTIC SYMBOL (90 MILS)		
UA	LEFT ARROW	
UB	RIGHT ARROW	
UC	STRAIGHT ARROW	
UE	COMBO. RIGHT/STRAIGHT ARROW	
THERMOPLASTIC CHARACTERS (120 MILS)		
UI	ALPHA-NUMERIC CHARACTERS	

### LEGEND

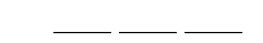
#### GENERAL

-  EXIST. PVMT.
-  NORTH ARROW
-  PROPOSED PVMT.

#### PAVEMENT MARKING SYMBOLS

-  PAVEMENT MARKING SYMBOLS

DOCUMENT NOT CONSIDERED FINAL  
UNLESS ALL SIGNATURES COMPLETED

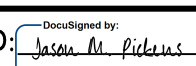
APPROVED:  DATE: 6/9/2016

SEAL

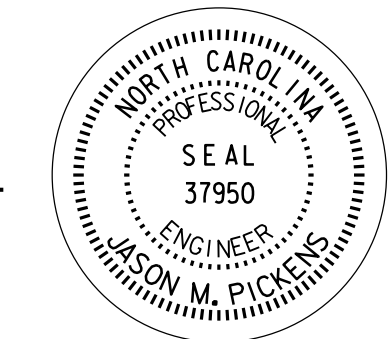
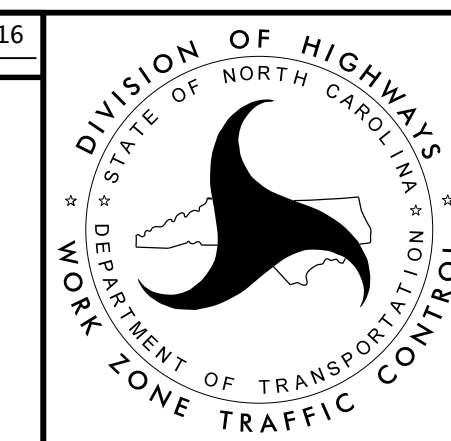



FINAL PAVEMENT  
MARKING SCHEDULE  
& LEGEND

PLANS PREPARED BY:  
**PARSONS**  
5400 CENTERVIEW DR., SUITE 301  
RALEIGH, NORTH CAROLINA 27606  
NC LICENSE NO. F-10246  
FOR NORTH CAROLINA DEPT. OF TRANSPORTATION

7/2/19

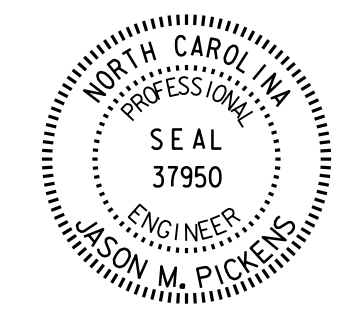
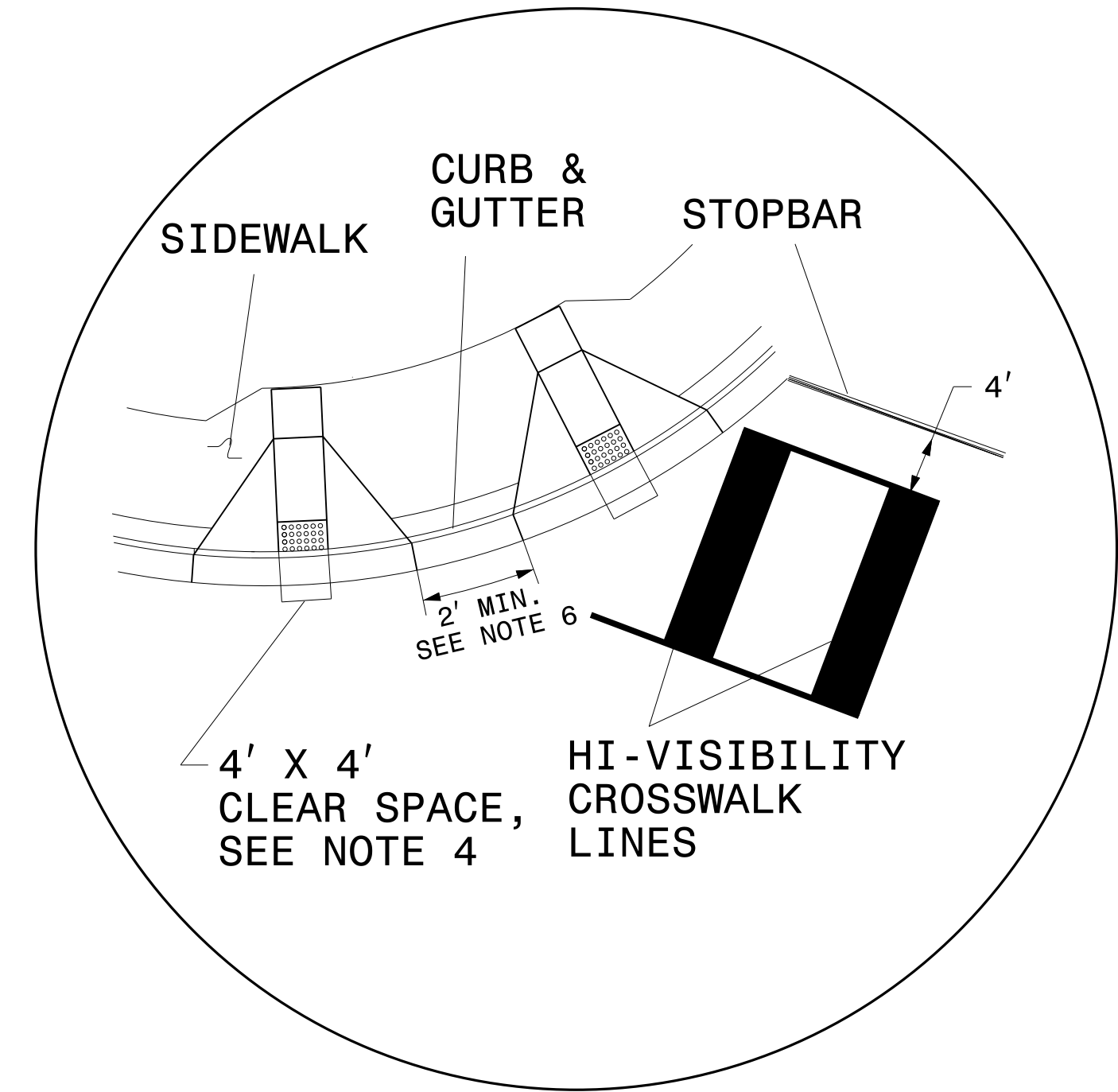
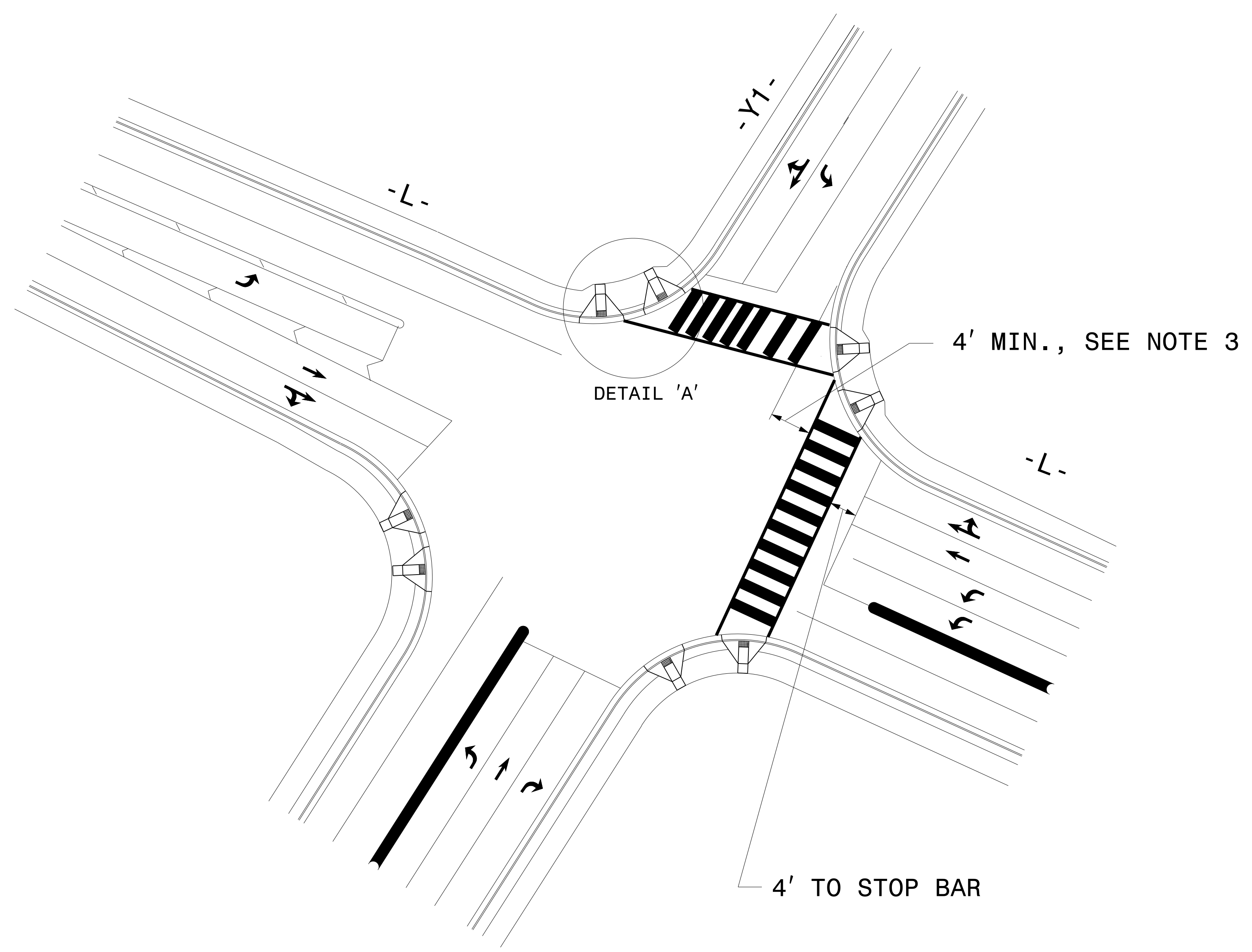
TIP NO. W-5203AA	SHEET NO. PMP-1B
APPROVED: <i>Jason M. Picketts</i> 300648022F4AD6	
DATE: 6/9/2016	
SEAL	





DETAIL 'A'- DUAL CURB RAMPS

### GUIDANCE DETAIL FOR CROSSWALK MARKINGS

NOTES:

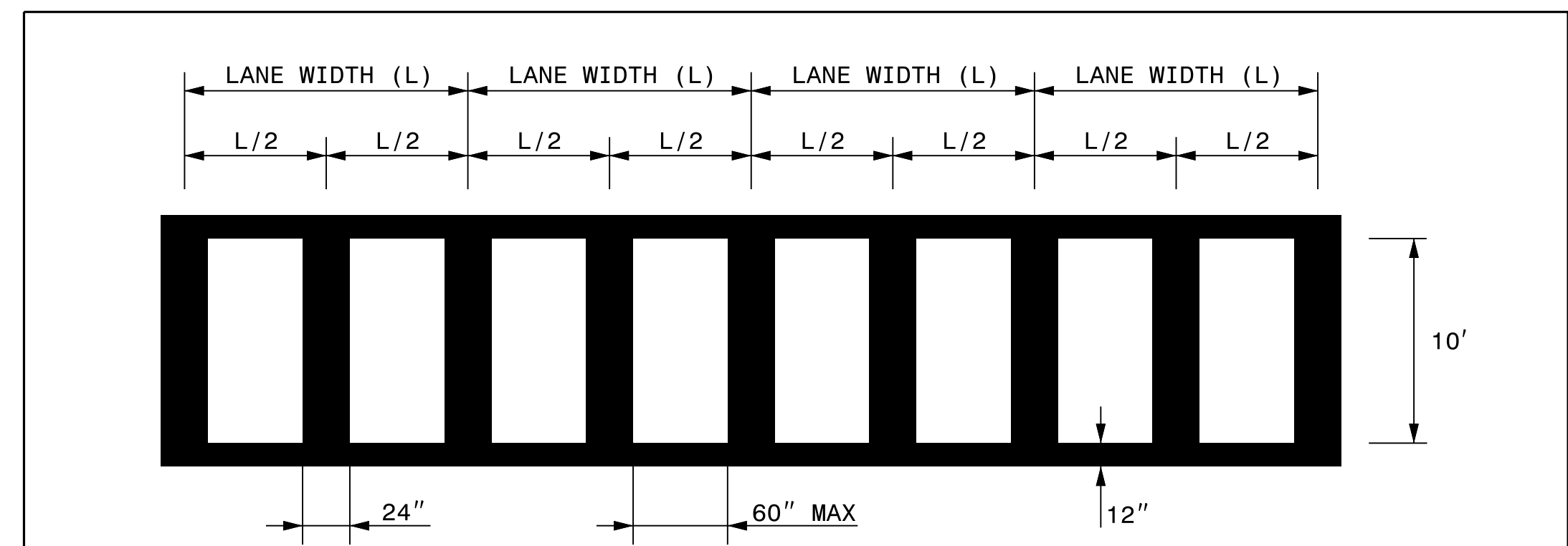
- USE THE DETAILS ABOVE AND THE FOLLOWING NOTES FOR GUIDANCE IN PLACING CROSSWALK MARKINGS NOT STATIONED ON THE DETAIL SHEETS OR WHEN FIELD ADJUSTMENTS REQUIRED MOVING STATIONED MARKINGS AS DIRECTED BY THE ENGINEER. REFER TO NCDOT ROADWAY STANDARD DRAWINGS, MUTCD AND ADA STANDARDS FOR ADDITIONAL GUIDANCE.
- THE CROSSWALK MARKINGS SHOWN ON THE ABOVE DETAILS ARE FOR REFERENCE ONLY. ONLY INSTALL CROSSWALK MARKINGS WHERE SHOWN ON THE DETAIL SHEETS OR AS DIRECTED BY THE ENGINEER. THE CROSSWALK MARKING TYPE, STANDARD OR HI-VISIBILITY, SHALL BE INSTALL AS SPECIFIED ON THE DETAIL SHEETS OR AS DIRECTED BY THE ENGINEER.
- SET BACK DISTANCE FROM INSIDE CROSSWALK MARKING TO NEAREST EDGE OF TRAVEL IS 4' MIN.
- BEYOND THE BOTTOM GRADE BRAKE, A CLEAR SPACE OF 4' X 4' MINIMUM SHALL BE PROVIDED WITHIN THE MARKINGS.
- SINGLE DIAGONAL CURB RAMPS WITH FLARED SIDES SHALL HAVE A SEGMENT OF CURB 2 FEET LONG MINIMUM LOCATED ON EACH SIDE OF THE CURB RAMP AND WITHIN THE MARKED CROSSING, SEE DETAIL 'B'.
- CURB RAMPS SHALL BE CONSTRUCTED IN ACCORDANCE TO THE LATEST NCDOT ROADWAY STANDARD DRAWINGS.



NOTES:

- PER MUTCD STANDARDS, WHEN CROSSWALK LINES ARE USED THEY SHALL CONSIST OF SOLID WHITE LINES THAT MARK THE CROSSWALKS. THEY SHALL NOT BE LESS THAN 6" NOR GREATER THAN 24" IN WIDTH.
- THE MARKING DESIGN SHOULD AVOID THE WHEEL PATHS AND THE SPACING SHOULD NOT EXCEED 60" IN WIDTH.



### SPECIAL EMPHASIS CROSSWALK MARKING DETAIL

DOCUMENT NOT CONSIDERED FINAL  
UNLESS ALL SIGNATURES COMPLETED

PLANS PREPARED BY:  
**PARSONS**  
5540 CENTERVIEW DRIVE, SUITE 201  
RALEIGH, NORTH CAROLINA 27606  
N.C. LICENSE NO. P-1046  
FOR NORTH CAROLINA DEPT. OF TRANSPORTATION

## CROSSWALK PAVEMENT MARKING GUIDANCE DETAIL

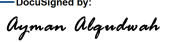
25-MAY-2016 13:26  
S:\M\2016\1326\PROJECTS\NMP\W-5203AA\_PMP\_01B.dgn  
\$\$\$\$\$SERNAME\$\$\$\$\$

TIP NO. W-5203AA	SHEET NO. PMP-1C
APPROVED: 	
DATE: 6/9/2016	
SEAL 	

STATE OF NORTH CAROLINA  
DEPT. OF TRANSPORTATION  
DIVISION OF HIGHWAYS  
RALEIGH, N.C.

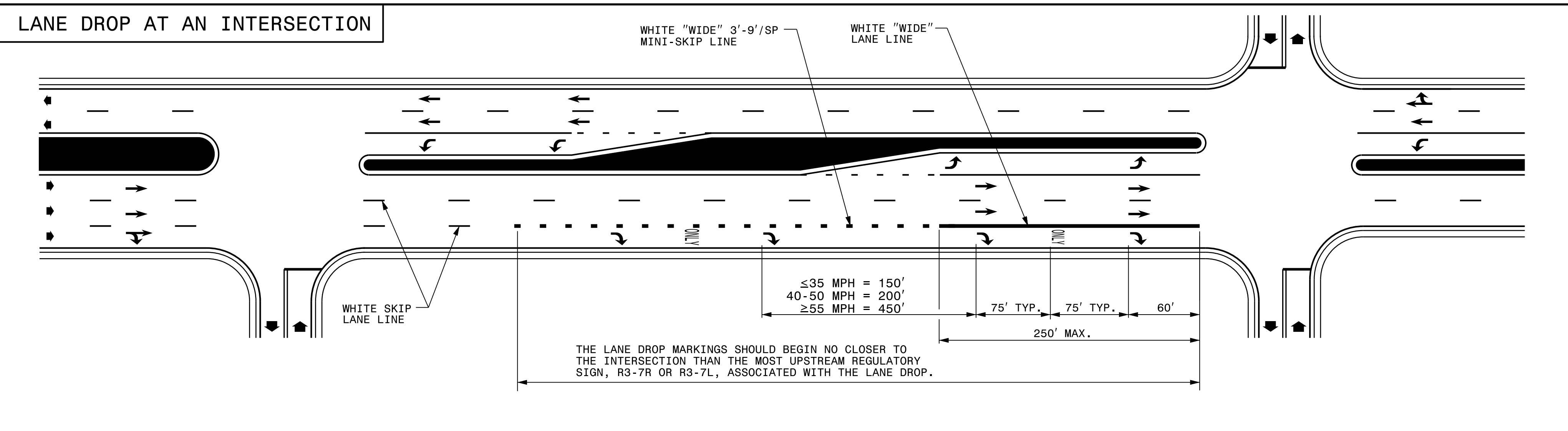

STATE OF NORTH CAROLINA  
DEPT. OF TRANSPORTATION  
DIVISION OF HIGHWAYS  
RALEIGH, N.C.

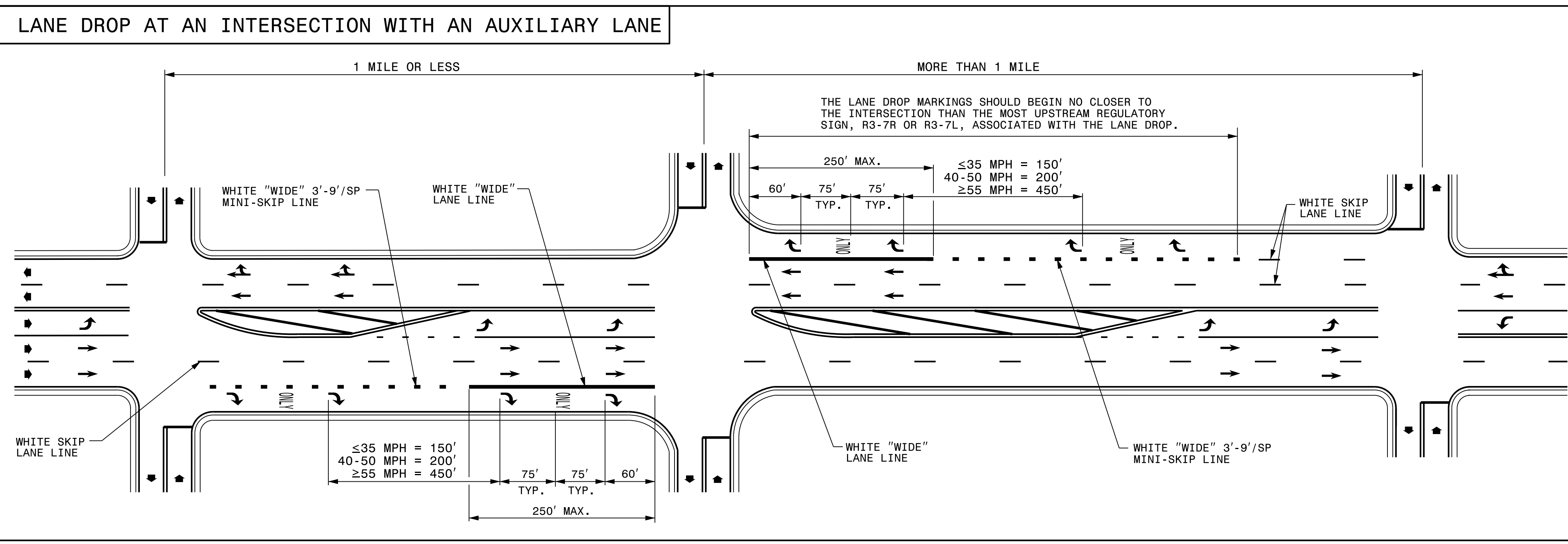

ENGLISH DETAIL DRAWING FOR  
PAVEMENT MARKINGS  
LANE DROPS



ENGLISH DETAIL DRAWING FOR  
PAVEMENT MARKINGS  
LANE DROPS

GENERAL NOTES:

- USE THE GUIDANCE SHOWN ON THE ABOVE DETAILS IN CONJUNCTION WITH INTERSECTION GUIDANCE SHOWN ON ROADWAY STANDARD DRAWING 1205.04.
- LANE LINES INDICATED AS "WIDE" SHALL BE AT LEAST TWICE THE WIDTH OF THE NORMAL LINE.

LEGEND	
W = WIDTH OF TRAVEL LANE	 PAVEMENT MARKING SYMBOLS & CHARACTERS
 DIRECTION OF TRAFFIC FLOW	

SHEET 1 OF 3  
**1205D06**

SHEET 1 OF 3  
**1205D06**

DOCUMENT NOT CONSIDERED FINAL  
UNLESS ALL SIGNATURES COMPLETED

**REVISED PAVEMENT MARKING  
ROADWAY STANDARD DRAWING**

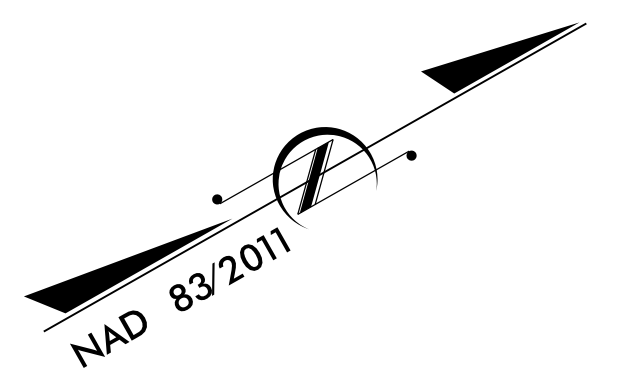

- CURB RAMP LOCATIONS:**
- ① -L- 416+66 +/- 76' LT
  - ② -L- 416+69 +/- 83' LT
  - ③ -L- 416+77 +/- 77' RT
  - ④ -L- 416+88 +/- 90' RT
  - ⑤ -L- 417+21 +/- 87' LT
  - ⑥ -L- 417+34 +/- 77' LT
  - ⑦ -L- 417+29 +/- 90' RT
  - ⑧ -L- 417+40 +/- 77' RT
  - ⑨ -L- 422+77 +/- 78' RT
  - ⑩ -L- 426+64 +/- 71' LT
  - ⑪ -L- 426+77 +/- 82' LT
  - ⑫ -L- 426+56 +/- 72' RT
  - ⑬ -L- 426+68 +/- 82' RT
  - ⑭ -L- 427+27 +/- 87' LT
  - ⑮ -L- 427+38 +/- 75' LT
  - ⑯ -L- 427+33 +/- 88' RT
  - ⑰ -L- 427+39 +/- 72' RT

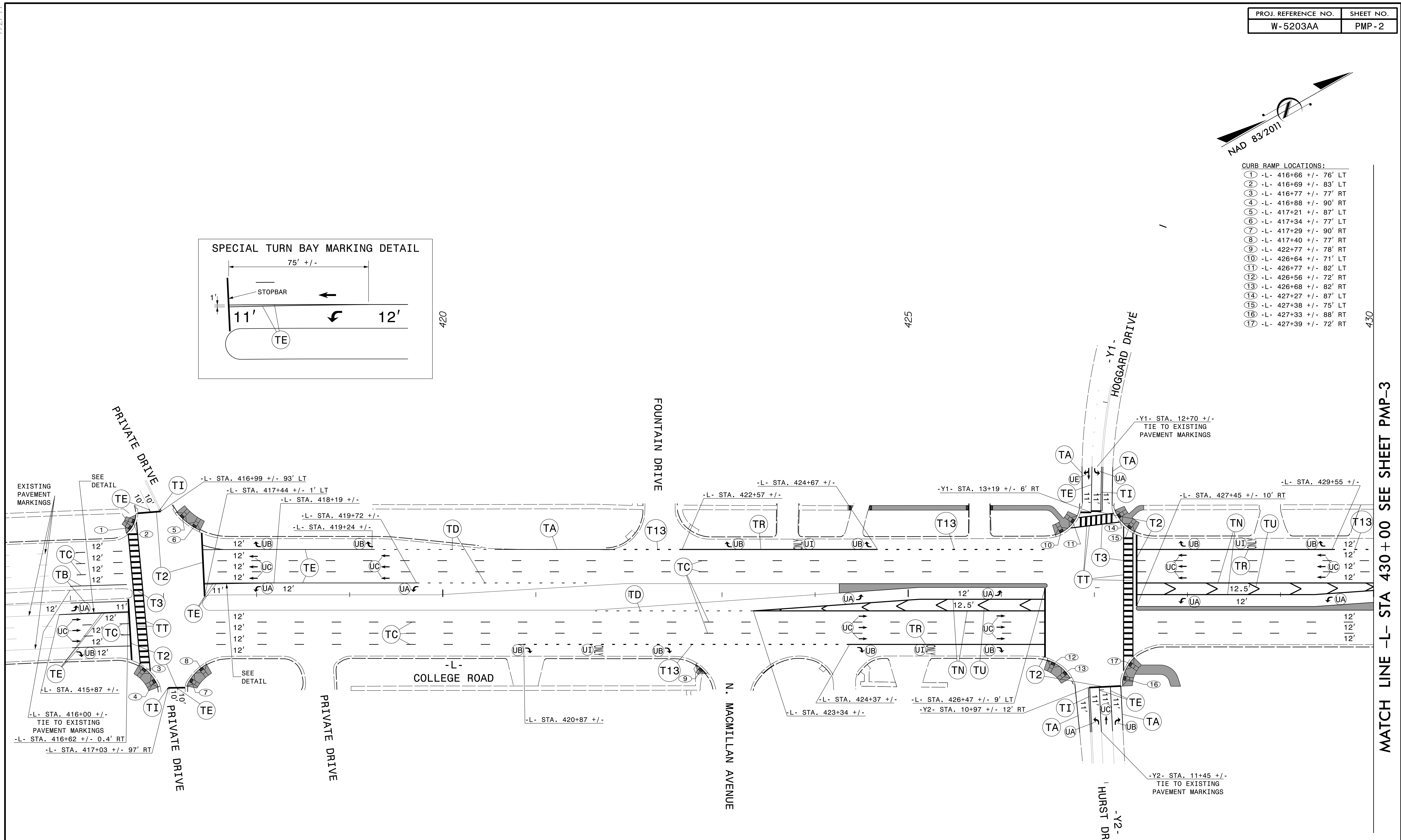
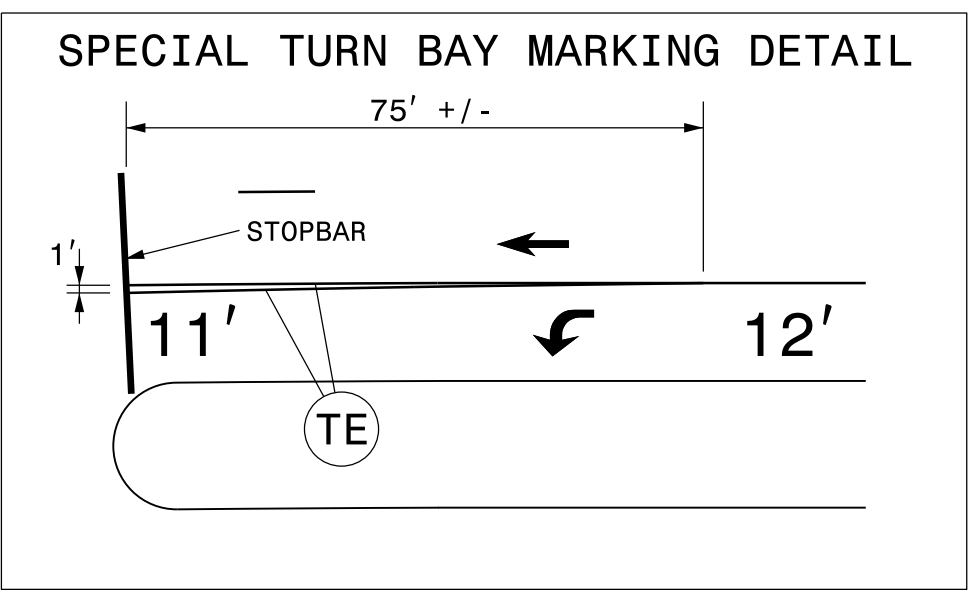

7/22/99  
 25-MAY-2016 13:26  
 J:\W-5203AA\T\Office\VPMP\W-5203AA\_PMP\_02.dgn  
 \$\$\$USERNAME\$\$\$

MATCH LINE -L- STA 430 + 00 SEE SHEET PMP-3

**DOCUMENT NOT CONSIDERED FINAL UNLESS ALL SIGNATURES COMPLETED**

APPROVED: *Jason M. Pickens* DATE: 6/9/2016

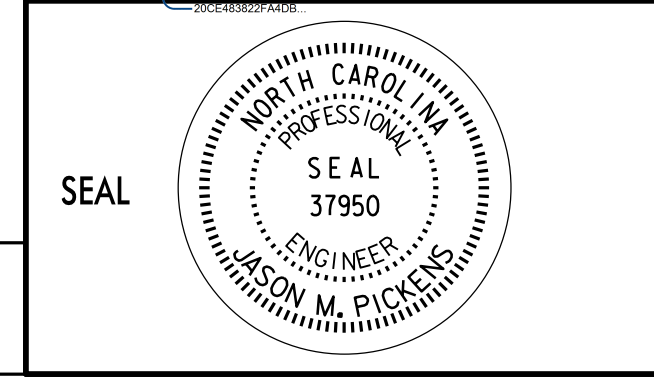

PLANS PREPARED BY  
**PARSONS**  
 5540 CENTERVIEW DR., SUITE 207  
 RALEIGH, NORTH CAROLINA 27606  
 NC LICENSE NO. F 0248  
 FOR NORTH CAROLINA DEPT. OF TRANSPORTATION

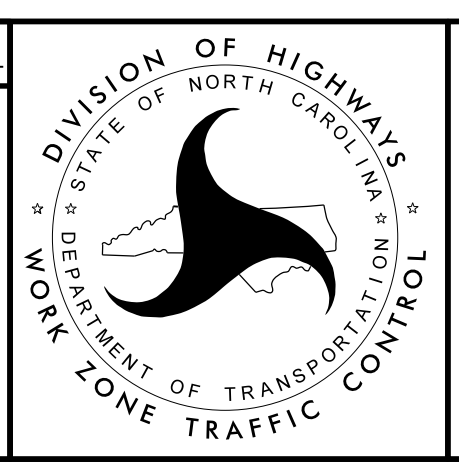

**FINAL PAVEMENT MARKING PLANS**

7/2/99

- CURB RAMP LOCATIONS:**
- ⑱ -L- 435+62 +/- 71' LT
  - ⑲ -L- 435+70 +/- 76' RT
  - ⑳ -L- 435+76 +/- 81' RT
  - ㉑ -L- 436+16 +/- 79' LT
  - ㉒ -L- 436+28 +/- 69' LT
  - ㉓ -L- 436+33 +/- 82' RT
  - ㉔ -L- 436+43 +/- 69' RT

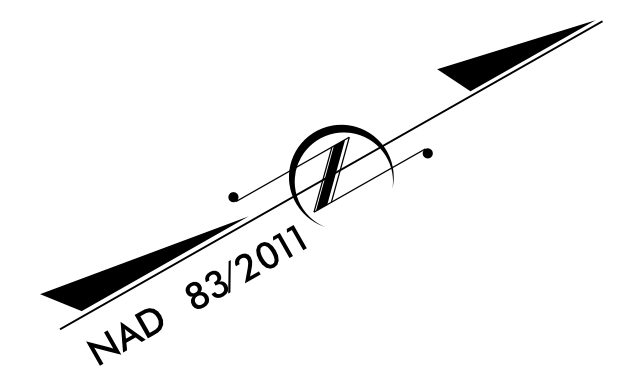

MATCH LINE -L- STA 430+00 SEE SHEET PMP-2

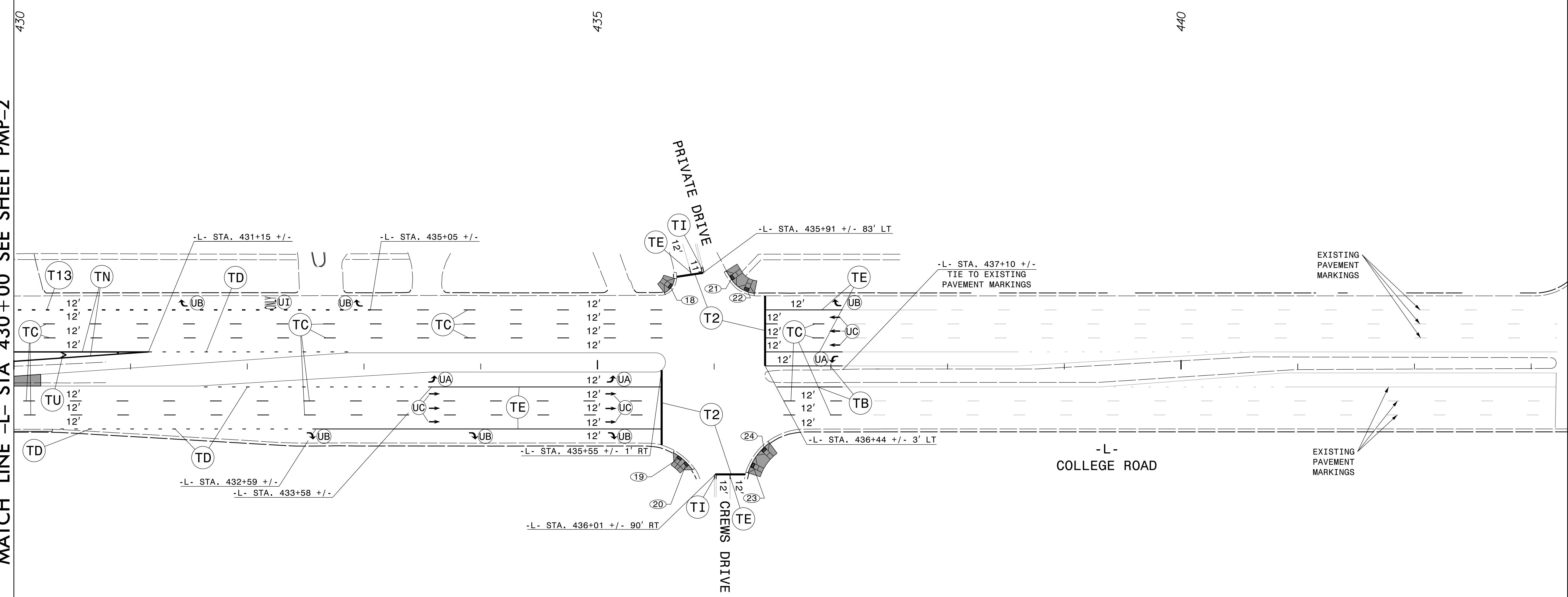

25-MAY-2016 13:26  
 J:\W-5203AA\T\Office\PMP\W-5203AA\_PMP\_03.dgn  
 \$\$\$USERNAME\$\$\$

DOCUMENT NOT CONSIDERED FINAL UNLESS ALL SIGNATURES COMPLETED

APPROVED: *Jason M. Picken* DATE: 6/9/2016

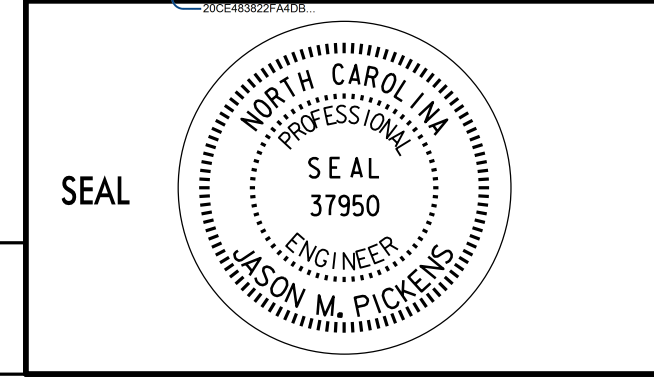

PLANS PREPARED BY  
**PARSONS**  
 5540 CENTERVIEW DR., SUITE 207  
 RALEIGH, NORTH CAROLINA 27606  
 NC LICENSE NO. F 0246  
 FOR NORTH CAROLINA DEPT. OF TRANSPORTATION

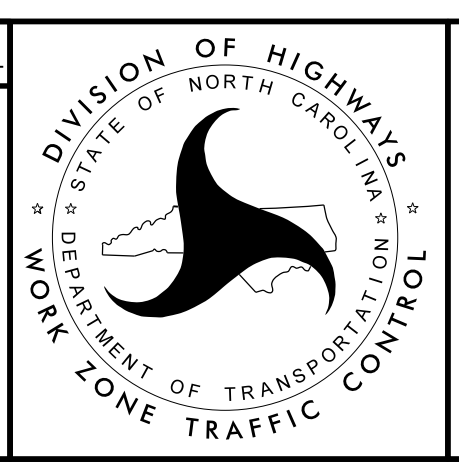

**FINAL PAVEMENT MARKING PLANS**