

**This electronic collection of documents is provided
for the convenience of the user
and is Not a Certified Document –**

**The documents contained herein were originally issued
and sealed by the individuals whose names and license
numbers appear on each page, on the dates appearing
with their signature on that page.**

**This file or an individual page
shall not be considered a certified document.**

STATE OF NORTH CAROLINA
DIVISION OF HIGHWAYS

TRANSPORTATION MANAGEMENT PLAN

IREDELL COUNTY

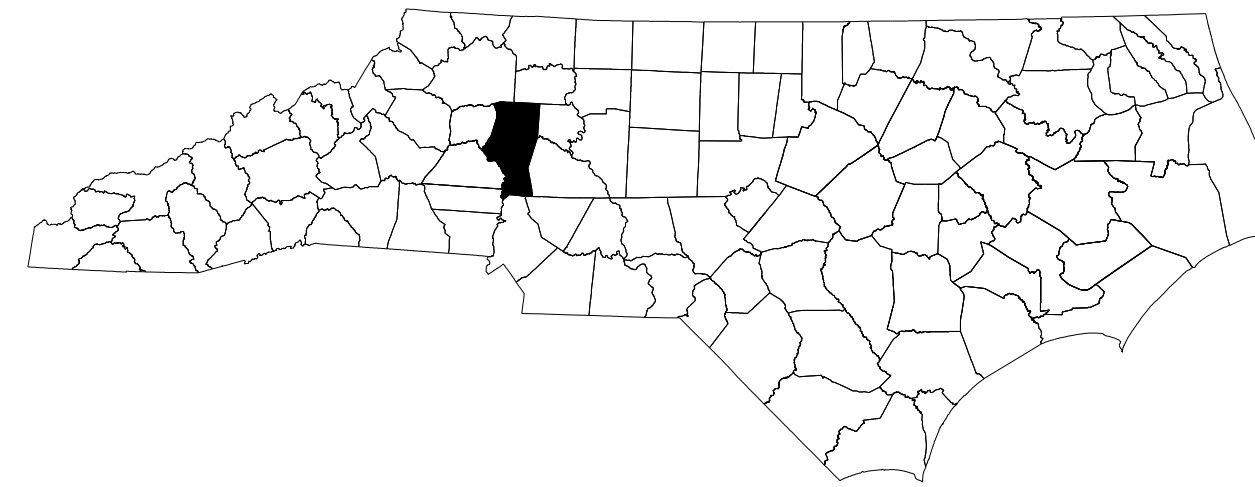

See Sheet 1-B For Conventional Symbols

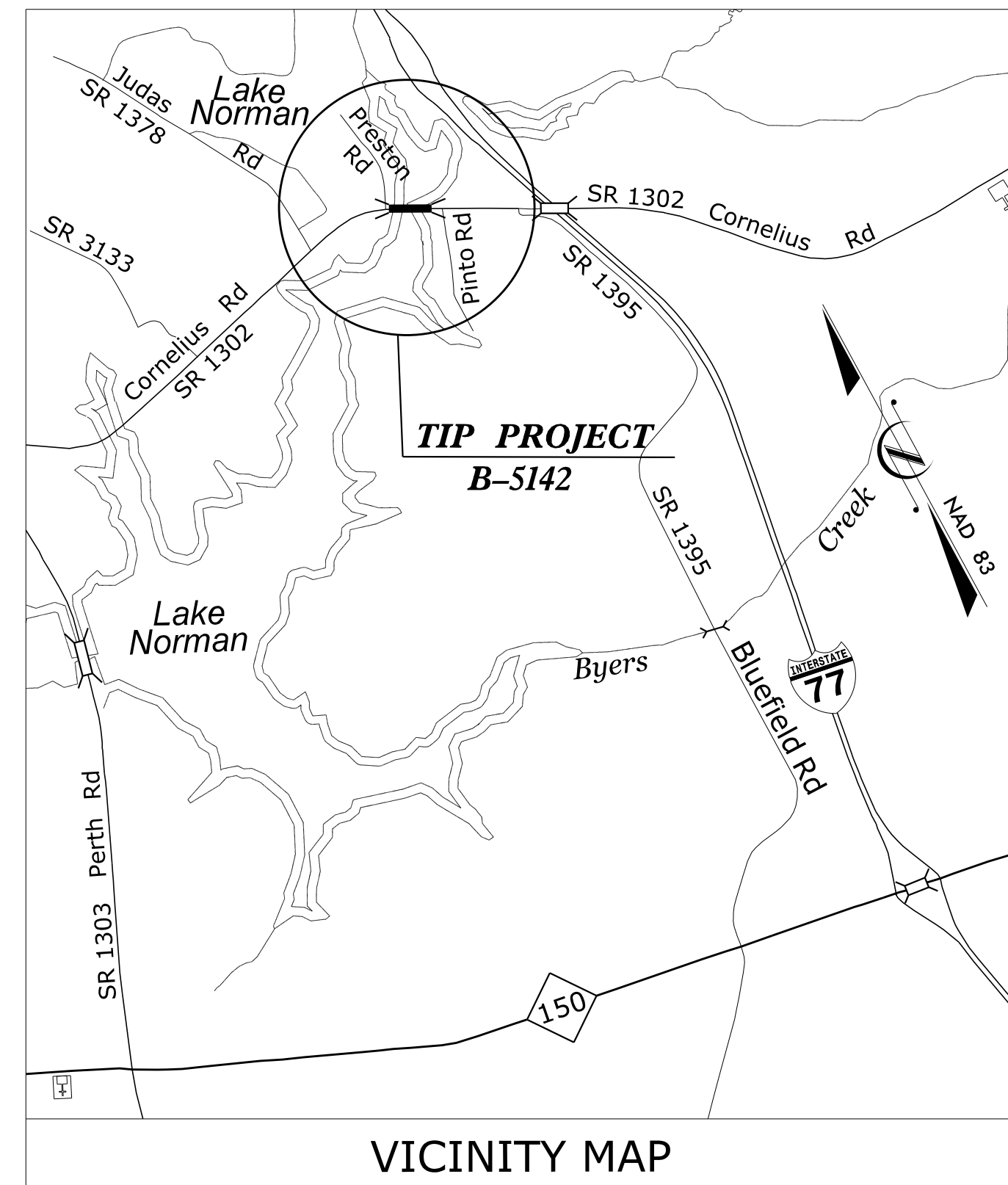

VICINITY MAP

SHEET NO.	TITLE
TMP-1	TITLE SHEET, VICINITY MAP AND INDEX OF SHEETS
TMP-1A	LIST OF APPLICABLE ROADWAY STANDARD DRAWINGS, AND LEGEND
TMP-1B-1C	TRANSPORTATION OPERATIONS PLAN: (MANAGEMENT STRATEGIES, GENERAL NOTES AND LOCAL NOTES)
TMP-1D	PORTABLE CONCRETE BARRIER AT TEMPORARY SHORING LOCATIONS
TMP-1E	TEMPORARY SHORING NOTES
TMP-2	PHASING
TMP-3	PHASE I STEP 2 DETAIL
TMP-3A	PHASE I SHORING DETAIL
TMP-4	PHASE I STEP 2 DETAIL
TMP-5-6	PHASE I STEP 3 DETAIL
TMP-7-8	PHASE I STEP 4 DETAIL
TMP-9-10	PHASE II DETAIL
TMP-11-12	PHASE III DETAIL

SHEET NO.
TMP-1

B-5142

TIP PROJECT:

10/5/2015
P:\TIP\Projects-B\B5142\TrafficControl\TCP\B-5142_TC_TMP_.ldgn
User:shassan

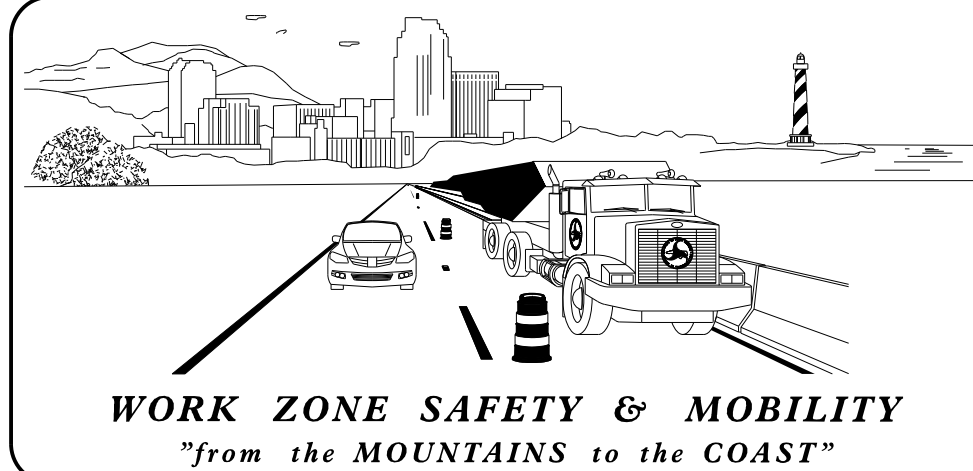

N.C.D.O.T. WORK ZONE TRAFFIC CONTROL
1561 MAIL SERVICE CENTER (MSC) RALEIGH, NC 27699-1561
750 N. GREENFIELD PARKWAY, GARNER, NC 27529 (DELIVERY)
PHONE: (919) 773-2800 FAX: (919) 771-2745

J. S. BOURNE, P.E. STATE TRAFFIC MANAGEMENT ENGINEER
J. W. WOOLARD, P.E. TRAFFIC CONTROL PROJECT ENGINEER
R. M. GARRETT TRAFFIC CONTROL PROJECT DESIGN ENGINEER
S. HASSAN, P.E. TRAFFIC CONTROL DESIGN ENGINEER

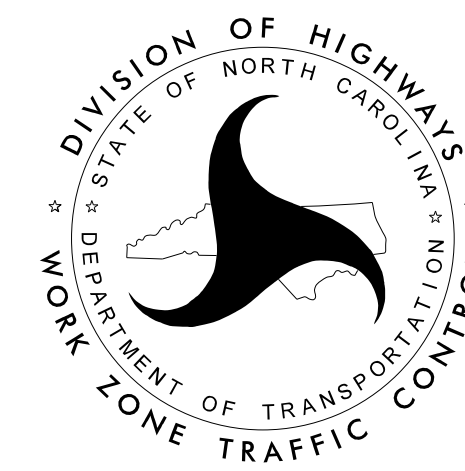

APPROVED: *J. W. Woolard, Jr.*
DATE: 10/6/2015

SEAL

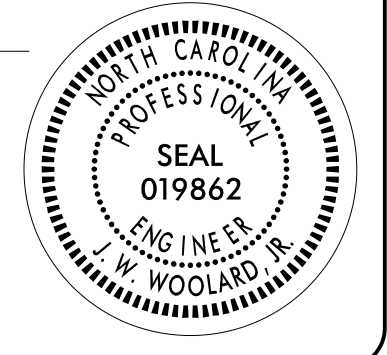

ROADWAY STANDARD DRAWINGS

THE FOLLOWING ROADWAY STANDARDS AS SHOWN IN "ROADWAY STANDARD DRAWINGS" - PROJECT SERVICES UNIT - N.C. DEPARTMENT OF TRANSPORTATION - RALEIGH, N.C., DATED JANUARY 2012 ARE APPLICABLE TO THIS PROJECT AND BY REFERENCE HEREBY ARE CONSIDERED A PART OF THESE PLANS:

STD. NO.	TITLE
1101.01	WORK ZONE ADVANCE WARNING SIGNS
1101.02	TEMPORARY LANE CLOSURES
1101.03	TEMPORARY ROAD CLOSURES
1101.04	TEMPORARY SHOULDER CLOSURES
1101.11	TRAFFIC CONTROL DESIGN TABLES
1110.01	STATIONARY WORK ZONE SIGNS
1110.02	PORTABLE WORK ZONE SIGNS
1130.01	DRUMS
1135.01	CONES
1145.01	BARRICADES
1150.01	FLAGGING DEVICES
1160.01	TEMPORARY CRASH CUSHION
1165.01	WORK VEHICLE LIGHTING SYSTEMS AND TMA DELINEATION
1170.01	POSITIVE PROTECTION
1180.01	SKINNY - DRUM
1205.01	PAVEMENT MARKINGS - LINE TYPES AND OFFSETS
1205.02	PAVEMENT MARKINGS - TWO LANE AND MULTILANE ROADWAYS
1205.04	PAVEMENT MARKINGS - INTERSECTIONS
1205.12	BRIDGES
1250.01	RAISED PAVEMENT MARKERS - INSTALLATION SPACING
1251.01	RAISED PAVEMENT MARKERS - (PERMANENT AND TEMPORARY)

LEGEND

GENERAL

- DIRECTION OF TRAFFIC FLOW
- DIRECTION OF PEDESTRIAN TRAFFIC FLOW
- EXIST. PVMT.
- NORTH ARROW
- PROPOSED PVMT.
- TEMP. SHORING (LOCATION PURPOSES ONLY)



SIGNALS

- EXISTING
- PROPOSED
- PORTABLE
- DRIVEWAY

PAVEMENT MARKINGS

- EXISTING LINES
- TEMPORARY LINES

TRAFFIC CONTROL DEVICES

- BARRICADE (TYPE III)
- CONE
- DRUM
- SKINNY DRUM
- TUBULAR MARKER
- TEMPORARY CRASH CUSHION
- FLASHING ARROW BOARD
- FLAGGER
- LAW ENFORCEMENT
- TRUCK MOUNTED ATTENUATOR (TMA)
- CHANGEABLE MESSAGE SIGN

TEMPORARY SIGNING

- PORTABLE SIGN
- STATIONARY SIGN
- STATIONARY OR PORTABLE SIGN

PAVEMENT MARKERS

- CRYSTAL/CRYSTAL
- CRYSTAL/RED
- YELLOW/YELLOW

PAVEMENT MARKING SYMBOLS

- PAVEMENT MARKING SYMBOLS

TEMPORARY PAVEMENT MARKING

PAINT (4")

- PA WHITE EDGE LINE
- PI YELLOW DOUBLE CENTER LINE
- P8 WHITE 2'-6'/SP MINI-SKIP LINE

COLD-APPLIED PLASTIC (4")

- CA WHITE EDGE LINE

COLD-APPLIED PLASTIC (24")

- C2 WHITE STOP BAR

APPROVED: DATE: 10/6/2015 SEAL			ROADWAY STANDARD DRAWINGS & LEGEND
--------------------------------------	--	--	---------------------------------------

MANAGEMENT STRATEGIES

- DURING CONSTRUCTION, TRAFFIC SR 1302 (CORNELIUS RD) WILL BE PLACED IN A ONE-LANE, TWO-WAY PATTERN UTILIZING BOTH EXISTING AND PROPOSED ROADWAYS AND STRUCTURES.
- DURING CONSTRUCTION FOR INTERSECTING DRIVEWAYS, TRAFFIC WILL USE DETOURS ON EXISTING ROADWAYS.
- WEDGING AND LEVELING, PLACEMENT OF FINAL SURFACE COURSE, AND PAVEMENT MARKINGS WILL BE PERFORMED BY USING FLAGGER OPERATIONS.
- TIE-IN CONSTRUCTION AND TRAFFIC SHIFTS WILL BE PERFORMED USING FLAGGER OPERATIONS AND PORTABLE SIGNAL SYSTEMS.

GENERAL NOTES / LOCAL NOTES

CHANGES MAY BE REQUIRED WHEN PHYSICAL DIMENSIONS IN THE DETAIL DRAWINGS, STANDARD DETAILS, AND ROADWAY DETAILS ARE NOT ATTAINABLE TO MEET FIELD CONDITIONS OR RESULT IN DUPLICATE OR UNDESIRED OVERLAPPING OF DEVICES. MODIFICATION MAY INCLUDE: MOVING, SUPPLEMENTING, COVERING, OR REMOVAL OF DEVICES AS DIRECTED BY THE ENGINEER.

THE FOLLOWING GENERAL NOTES APPLY AT ALL TIMES FOR THE DURATION OF THE CONSTRUCTION PROJECT EXCEPT WHEN OTHERWISE NOTED IN THE PLAN OR DIRECTED BY THE ENGINEER.

TIME RESTRICTIONS

A) DO NOT CLOSE OR NARROW TRAVEL LANES AS FOLLOWS:

ROAD NAME	DAY AND TIME RESTRICTIONS
CORNELIUS RD (SR 1302)	MONDAY - FRIDAY 7:00 AM - 9:00 AM 3:00 PM - 7:00 PM
	SATURDAY AND SUNDAY 6:00 AM - 7:00 PM

B) DO NOT CLOSE OR NARROW TRAVEL LANES DURING HOLIDAYS AND SPECIAL EVENTS AS FOLLOWS:

ROAD NAME	HOLIDAY
CORNELIUS RD (SR 1302)	1. FOR ANY UNEXPECTED OCCURRENCE THAT CREATES UNUSUALLY HIGH TRAFFIC VOLUMES, AS DIRECTED BY THE ENGINEER.
	2. FOR NEW YEAR'S, BETWEEN THE HOURS OF 7:00 A.M. DECEMBER 31st TO 7:00 P.M. JANUARY 2ND. IF NEW YEAR'S DAY IS ON A FRIDAY, SATURDAY, SUNDAY, OR MONDAY THEN UNTIL 7:00 P.M. THE FOLLOWING TUESDAY.
	3. FOR EASTER, BETWEEN THE HOURS OF 7:00 A.M. THURSDAY AND 7:00 P.M. MONDAY.
	4. FOR MEMORIAL DAY, BETWEEN THE HOURS OF 7:00 A.M. FRIDAY TO 7:00 P.M. TUESDAY.
	5. FOR INDEPENDENCE DAY, BETWEEN THE HOURS OF 7:00 A.M. THE DAY BEFORE INDEPENDENCE DAY AND 7:00 P.M. THE DAY AFTER INDEPENDENCE DAY. IF INDEPENDENCE DAY IS ON A FRIDAY, SATURDAY, SUNDAY OR MONDAY THEN BETWEEN THE HOURS OF 7:00 A.M. THE THURSDAY BEFORE INDEPENDENCE DAY AND 7:00 P.M. THE TUESDAY AFTER INDEPENDENCE DAY.
	6. FOR LABOR DAY, BETWEEN THE HOURS OF 7:00 A.M. FRIDAY AND 7:00 P.M. TUESDAY.
	7. FOR THANKSGIVING DAY, BETWEEN THE HOURS OF 7:00 A.M. TUESDAY TO 7:00 P.M. MONDAY.
	8. FOR CHRISTMAS, BETWEEN THE HOURS OF 7:00 A.M. THE FRIDAY BEFORE THE WEEK OF CHRISTMAS DAY AND 7:00 P.M. THE FOLLOWING TUESDAY AFTER THE WEEK OF CHRISTMAS.

C) DO NOT CONDUCT ANY HAULING OPERATIONS AGAINST THE FLOW OF TRAFFIC OF AN OPEN TRAVELWAY UNLESS THE HAULING OPERATION IS PROTECTED BY BARRIER OR GUARDRAIL OR AS DIRECTED BY THE ENGINEER.

LANE AND SHOULDER CLOSURE REQUIREMENTS

- D) REMOVE LANE CLOSURE DEVICES FROM THE LANE WHEN WORK IS NOT BEING PERFORMED BEHIND THE LANE CLOSURE OR WHEN A LANE CLOSURE IS NO LONGER NEEDED OR AS DIRECTED BY THE ENGINEER.
- E) WHEN PERSONNEL AND/OR EQUIPMENT ARE WORKING WITHIN 15 FT OF AN OPEN TRAVEL LANE, CLOSE THE NEAREST OPEN SHOULDER USING ROADWAY STANDARD DRAWING NO. 1101.04 UNLESS THE WORK AREA IS PROTECTED BY BARRIER OR GUARDRAIL OR A LANE CLOSURE IS INSTALLED.
- F) WHEN PERSONNEL AND/OR EQUIPMENT ARE WORKING ON THE SHOULDER ADJACENT TO AN UNDIVIDED FACILITY AND WITHIN 5 FT OF AN OPEN TRAVEL LANE, CLOSE THE NEAREST OPEN TRAVEL LANE USING ROADWAY STANDARD DRAWING NO. 1101.02 UNLESS THE WORK AREA IS PROTECTED BY BARRIER OR GUARDRAIL.

WHEN PERSONNEL AND/OR EQUIPMENT ARE WORKING ON THE SHOULDER ADJACENT TO A DIVIDED FACILITY AND WITHIN 10 FT OF AN OPEN TRAVEL LANE, CLOSE THE NEAREST OPEN TRAVEL LANE USING ROADWAY STANDARD DRAWING NO. 1101.02 UNLESS THE WORK AREA IS PROTECTED BY BARRIER OR GUARDRAIL.
- G) WHEN PERSONNEL AND/OR EQUIPMENT ARE WORKING WITHIN A LANE OF TRAVEL OF AN UNDIVIDED OR DIVIDED FACILITY, CLOSE THE LANE ACCORDING TO THE TRAFFIC CONTROL PLANS, ROADWAY STANDARD DRAWINGS, OR AS DIRECTED BY THE ENGINEER. CONDUCT THE WORK SO THAT ALL PERSONNEL AND/OR EQUIPMENT REMAIN WITHIN THE CLOSED TRAVEL LANE.
- H) DO NOT WORK SIMULTANEOUSLY WITHIN 15 FT ON BOTH SIDES OF AN OPEN TRAVELWAY, RAMP, OR LOOP WITHIN THE SAME LOCATION UNLESS PROTECTED WITH GUARDRAIL OR BARRIER.
- I) DO NOT INSTALL MORE THAN ONE LANE CLOSURE IN ANY ONE DIRECTION ON ANY ROAD.
- J) PROVIDE TRAFFIC CONTROL FOR APPROPRIATE LANE CLOSURES FOR SURVEYING DONE BY THE DEPARTMENT.

PAVEMENT EDGE DROP OFF REQUIREMENTS

- K) BACKFILL AT A 6:1 SLOPE UP TO THE EDGE AND ELEVATION OF EXISTING PAVEMENT IN AREAS ADJACENT TO AN OPENED TRAVEL LANE THAT HAS AN EDGE OF PAVEMENT DROP-OFF AS FOLLOWS:

BACKFILL DROP-OFFS THAT EXCEED 2 INCHES ON ROADWAYS WITH POSTED SPEED LIMITS OF 45 MPH OR GREATER.

BACKFILL DROP-OFFS THAT EXCEED 3 INCHES ON ROADWAYS WITH POSTED SPEED LIMITS LESS THAN 45 MPH.

BACKFILL WITH SUITABLE COMPACTED MATERIAL, AS APPROVED BY THE ENGINEER, AT NO EXPENSE TO THE DEPARTMENT.
- L) DO NOT EXCEED A DIFFERENCE OF 2 INCHES IN ELEVATION BETWEEN OPEN LANES OF TRAFFIC FOR NOMINAL LIFTS OF 1.5 INCHES. INSTALL ADVANCE WARNING "UNEVEN LANES" SIGNS (W8-11) 500 FT IN ADVANCE AND A MINIMUM OF EVERY HALF MILE THROUGHOUT THE UNEVEN AREA.

TRAFFIC PATTERN ALTERATIONS

- M) NOTIFY THE ENGINEER TWENTY ONE (21) CALENDAR DAYS PRIOR TO ANY TRAFFIC PATTERN ALTERATION.

APPROVED: <i>J. W. Woodard Jr.</i> <small>079C1REBADR427</small> DATE: 11/30/2015			<h2 style="text-align: center;">TRANSPORTATION OPERATIONS PLAN</h2>
---	--	--	---

GENERAL NOTES / LOCAL NOTES (CONTINUED)

SIGNING

- N) INSTALL ADVANCE WORK ZONE WARNING SIGNS WHEN WORK IS WITHIN 40 FT FROM THE EDGE OF TRAVEL LANE AND NO MORE THAN THREE (3) DAYS PRIOR TO THE BEGINNING OF CONSTRUCTION.
- O) ENSURE ALL NECESSARY SIGNING IS IN PLACE PRIOR TO ALTERING ANY TRAFFIC PATTERN.
- P) INSTALL BLACK ON ORANGE "DIP" SIGNS (W8-2) AND/OR "BUMP" SIGNS (W8-1) 500 FT IN ADVANCE OF THE UNEVEN AREA, OR AS DIRECTED BY THE ENGINEER.

TRAFFIC BARRIER

- Q) INSTALL TEMPORARY BARRIER ACCORDING TO THE TRAFFIC CONTROL PLANS A MAXIMUM OF TWO (2) WEEKS PRIOR TO BEGINNING WORK IN ANY LOCATION. ONCE TEMPORARY BARRIER IS INSTALLED AT ANY LOCATION PROCEED IN A CONTINUOUS MANNER TO COMPLETE THE PROPOSED WORK IN THAT LOCATION UNLESS OTHERWISE STATED IN THE TRAFFIC CONTROL PLANS OR AS DIRECTED BY THE ENGINEER.

DO NOT PLACE BARRIER DIRECTLY ON ANY SURFACE OTHER THAN ASPHALT OR CONCRETE.

ONCE TEMPORARY BARRIER IS INSTALLED AT ANY LOCATION AND NO WORK IS PERFORMED BEHIND THE TEMPORARY BARRIER FOR A PERIOD LONGER THAN TWO (2) MONTHS, REMOVE/RESET TEMPORARY BARRIER AT NO COST TO THE DEPARTMENT UNLESS OTHERWISE STATED IN THE TRAFFIC CONTROL PLANS, TEMPORARY BARRIER IS PROTECTING A HAZARD, OR AS DIRECTED BY THE ENGINEER.

INSTALL TEMPORARY BARRIER WITH THE TRAFFIC FLOW BEGINNING WITH THE UPSTREAM SIDE OF TRAFFIC. REMOVE TEMPORARY BARRIER AGAINST THE TRAFFIC FLOW BEGINNING WITH THE DOWNSTREAM SIDE OF TRAFFIC.

INSTALL AND SPACE DRUMS NO GREATER THAN TWICE THE POSTED SPEED LIMIT (MPH) TO CLOSE OR KEEP THE SECTION OF THE ROADWAY CLOSED UNTIL THE TEMPORARY BARRIER CAN BE PLACED OR AFTER THE TEMPORARY BARRIER IS REMOVED.

- R) PROTECT THE APPROACH END OF MOVABLE/PORTABLE CONCRETE BARRIER AT ALL TIMES DURING THE INSTALLATION AND REMOVAL OF THE BARRIER BY EITHER A TRUCK MOUNTED IMPACT ATTENUATOR (MAXIMUM 72 HOURS) OR A TEMPORARY CRASH CUSHION.

PROTECT THE APPROACH END OF MOVABLE/PORTABLE CONCRETE BARRIER FROM ONCOMING TRAFFIC AT ALL TIMES BY A TEMPORARY CRASH CUSHION UNLESS THE APPROACH END OF MOVABLE/PORTABLE CONCRETE BARRIER IS OFFSET FROM ONCOMING TRAFFIC AS FOLLOWS OR AS SHOWN IN THE PLANS:

POSTED SPEED LIMIT	MINIMUM OFFSET
40 OR LESS	15 FT
45 - 50	20 FT
55	25 FT
60 MPH or HIGHER	30 FT

TRAFFIC CONTROL DEVICES

- S) WHEN LANE CLOSURES ARE NOT IN EFFECT SPACE CHANNELIZING DEVICES IN WORK AREAS NO GREATER IN FEET THAN TWICE THE POSTED SPEED LIMIT (MPH) EXCEPT, 10 FT ON-CENTER IN RADII, AND 3 FT OFF THE EDGE OF AN OPEN TRAVELWAY. REFER TO STANDARD SPECIFICATIONS FOR ROADS AND STRUCTURES SECTIONS 1130 (DRUMS), 1135 (CONES), AND 1180 (SKINNY DRUMS) FOR ADDITIONAL REQUIREMENTS.
- T) PLACE TYPE III BARRICADES, WITH "ROAD CLOSED" SIGN R11-2 ATTACHED, OF SUFFICIENT LENGTH TO CLOSE ENTIRE ROADWAY.
- U) PLACE ADDITIONAL SETS OF THREE CHANNELIZING DEVICES (SKINNY DRUMS) PERPENDICULAR TO THE EDGE OF TRAVELWAY ON 500 FT CENTERS WHEN UNOPENED LANES ARE CLOSED TO TRAFFIC.
- V) INSTALL TEMPORARY PAVEMENT MARKINGS AND TEMPORARY PAVEMENT MARKERS ON INTERIM LAYERS OF PAVEMENT AS FOLLOWS:

ROAD NAME	MARKING	MARKER
ALL ROADS	PAINT	

- W) PLACE ONE APPLICATION OF PAINT FOR TEMPORARY TRAFFIC PATTERNS. PLACE A SECOND APPLICATION OF PAINT SIX (6) MONTHS AFTER THE INITIAL APPLICATION AND EVERY SIX MONTHS AS DIRECTED BY THE ENGINEER.
- X) TIE PROPOSED PAVEMENT MARKING LINES TO EXISTING PAVEMENT MARKING LINES.
- Y) REMOVE/REPLACE ANY CONFLICTING/DAMAGED PAVEMENT MARKINGS AND MARKERS BY THE END OF EACH DAY'S OPERATION.

MISCELLANEOUS

- Z) IN THE EVENT A TIE-IN CANNOT BE MADE IN ONE DAY'S TIME, BRING THE TIE-IN AREA TO AN APPROPRIATE ROADWAY ELEVATION AS DETERMINED BY THE ENGINEER. PLACE BLACK ON ORANGE "LOOSE GRAVEL" SIGNS (W8-7) AND BLACK ON ORANGE "PAVEMENT ENDS" SIGNS (W8-3) 500 FT AND 2000 FT RESPECTIVELY IN ADVANCE OF THE UNEVEN AREAS. USE DRUMS TO DELINEATE THE EDGE OF ROADWAY ALONG UNPAVED AREAS.

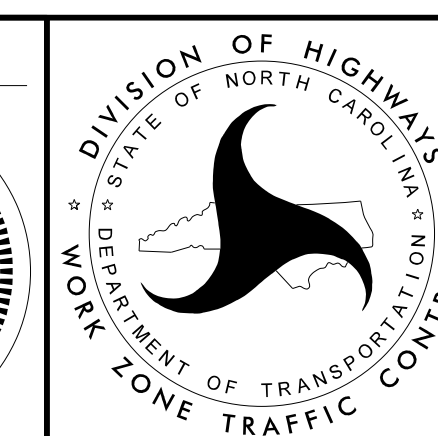
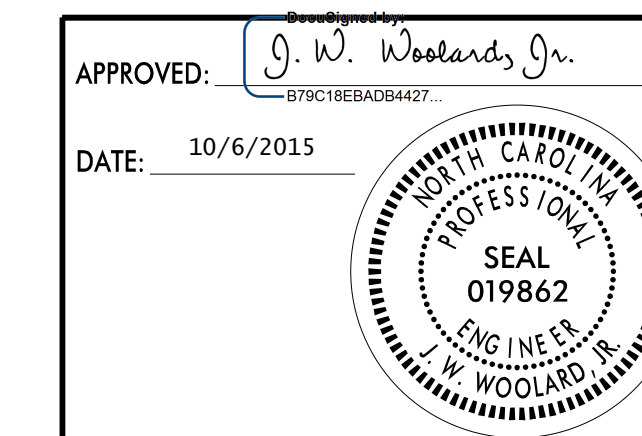

**TRANSPORTATION
OPERATIONS
PLAN**

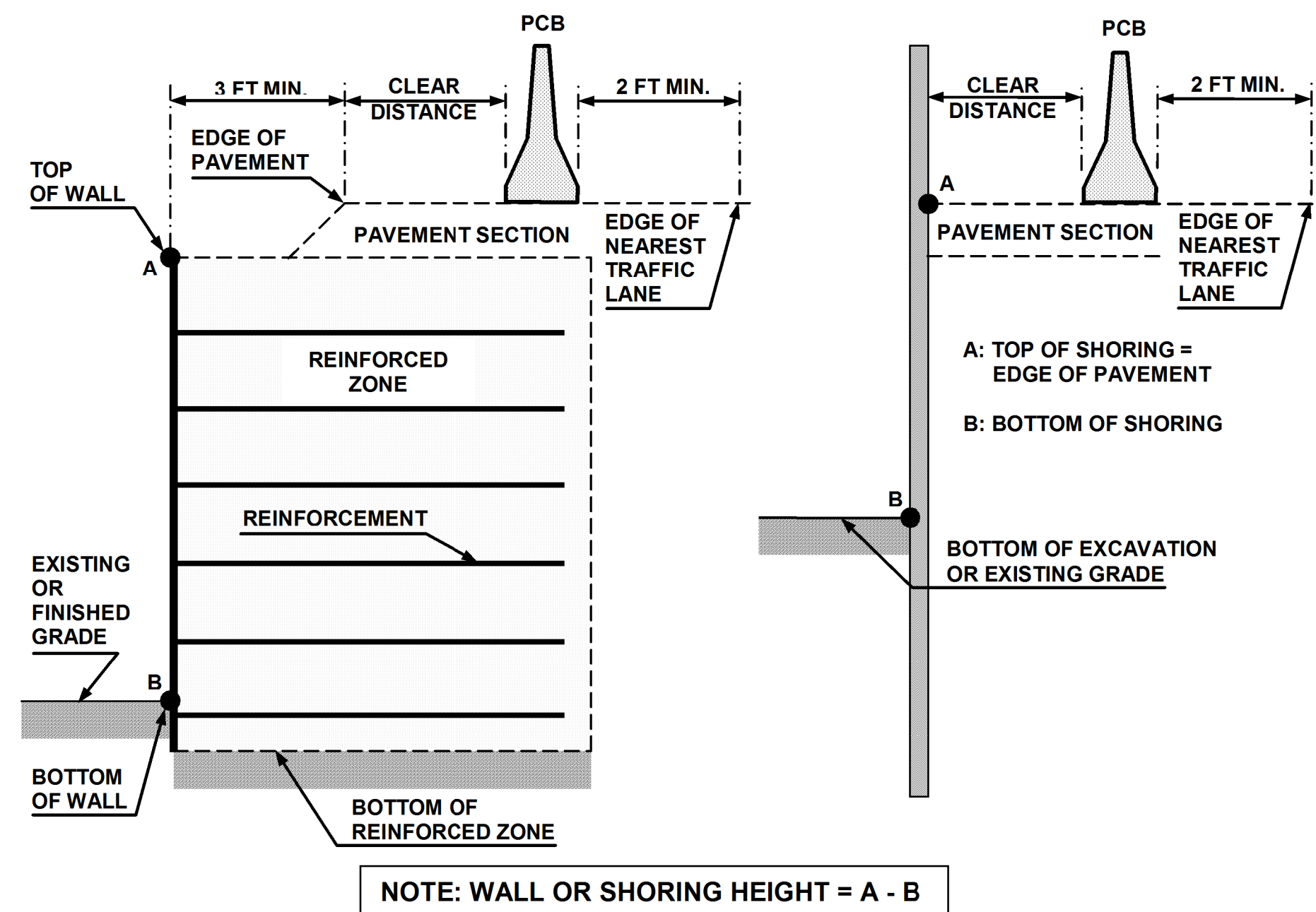

FIGURE A

NOTES

- REFER TO THE TRAFFIC CONTROL PLANS FOR TEMPORARY SHORING LOCATIONS AND NOTES.
- REFER TO THE "TEMPORARY SHORING" PROJECT SPECIAL PROVISION FOR INFORMATION ABOUT TEMPORARY SHORING AND PORTABLE CONCRETE BARRIER (PCB).
- PCB IS REQUIRED IF TEMPORARY SHORING IS LOCATED WITHIN THE CLEAR ZONE IN ACCORDANCE WITH THE AASHTO ROADSIDE DESIGN GUIDE. DO NOT PLACE BARRIER DIRECTLY ON ANY SURFACE OTHER THAN ASPHALT OR CONCRETE. (CONTACT NCDOT PAVEMENT MANAGEMENT UNIT FOR APPLICABLE PAVEMENT DESIGN).
- BASED ON THE CLEAR DISTANCE, OFFSET, DESIGN SPEED AND PAVEMENT TYPE, CHOOSE AN UNANCHORED OR ANCHORED PCB FROM THE TABLE SHOWN IN FIGURE B. CLEAR DISTANCE IS DEFINED AS SHOWN IN FIGURE A AND OFFSET IS DEFINED AS SHOWN IN FIGURE B.
- AT THE CONTRACTOR'S OPTION OR IF THE MINIMUM REQUIRED CLEAR DISTANCE IS NOT AVAILABLE, SET PCB NEXT TO AND UP AGAINST THE TRAFFIC SIDE OF THE TEMPORARY SHORING EXCEPT FOR BARRIER ABOVE TEMPORARY WALLS. PCB WITH THE MINIMUM REQUIRED CLEAR DISTANCE IS REQUIRED ABOVE TEMPORARY WALLS.
- USE NCDOT PORTABLE CONCRETE BARRIER (PCB) IN ACCORDANCE WITH ROADWAY STANDARD DRAWING NO. 1170.01 AND SECTION 1170 OF THE STANDARD SPECIFICATIONS.
- PCB REQUIREMENTS FOR TEMPORARY WALLS APPLY TO TEMPORARY MECHANICALLY STABILIZED EARTH (MSE) WALLS AND TEMPORARY SOIL NAIL WALLS.
- SET PCB WITH A MINIMUM HORIZONTAL DISTANCE OF 2 FT BETWEEN THE FRONT FACE OF THE BARRIER AND THE EDGE OF THE NEAREST TRAFFIC LANE AS SHOWN IN FIGURE A UNLESS OTHERWISE SHOWN IN THE PLANS AND OR AS APPROVED BY THE ENGINEER.
- FOR PCB ABOVE AND BEHIND TEMPORARY WALLS, PROVIDE A MINIMUM DISTANCE OF 3 FT BETWEEN THE EDGE OF PAVEMENT AND THE WALL FACE AS SHOWN IN FIGURE A. IF THESE MINIMUM REQUIRED DISTANCES ARE NOT AVAILABLE, CONTACT THE ENGINEER.
- TABLE SHOWN IN FIGURE B IS BASED ON NCDOT RESEARCH PROJECT NO. 2005-010 WITH VEHICLE TYPE USED FOR NCHRP 350 CRASH TESTS. BARRIER DEFLECTIONS AND RESULTING MINIMUM REQUIRED CLEAR DISTANCES MIGHT VARY SIGNIFICANTLY FOR LARGER HEAVIER VEHICLES, RUNS OF BARRIER LESS THAN 200 FT IN LENGTH AND WET OR DRY PAVEMENT.

MINIMUM REQUIRED CLEAR DISTANCE, inches

Barrier Type	Pavement Type	Offset * ft	Design Speed, mph					
			<30	31-40	41-50	51-60	61-70	71-80
Unanchored PCB	Asphalt	<8	24	26	29	32	36	40
		8-14	26	28	31	35	38	42
		14-20	27	29	34	36	39	43
		20-26	28	31	35	38	40	44
		26-32	29	32	36	39	42	45
		32-38	30	34	38	41	43	46
		38-44	31	34	41	43	45	48
		44-50	31	35	41	43	46	49
		50-56	32	36	42	44	47	50
	>56	32	36	42	45	47	51	
	Concrete	<8	17	18	21	22	25	26
		8-14	19	20	23	25	26	29
		14-20	22	22	24	26	28	31
		20-26	23	24	26	27	30	34
		26-32	24	25	27	28	32	35
		32-38	24	26	27	30	33	36
		38-44	25	26	28	30	34	37
		44-50	26	26	28	32	35	37
50-56		26	26	28	32	35	38	
>56	26	27	29	32	36	38		
Anchored PCB	Asphalt	All Offsets	24 for All Design Speeds					
Anchored PCB	Concrete (including bridge approach slabs)	All Offsets	12 for All Design Speeds					

* See Figure Below

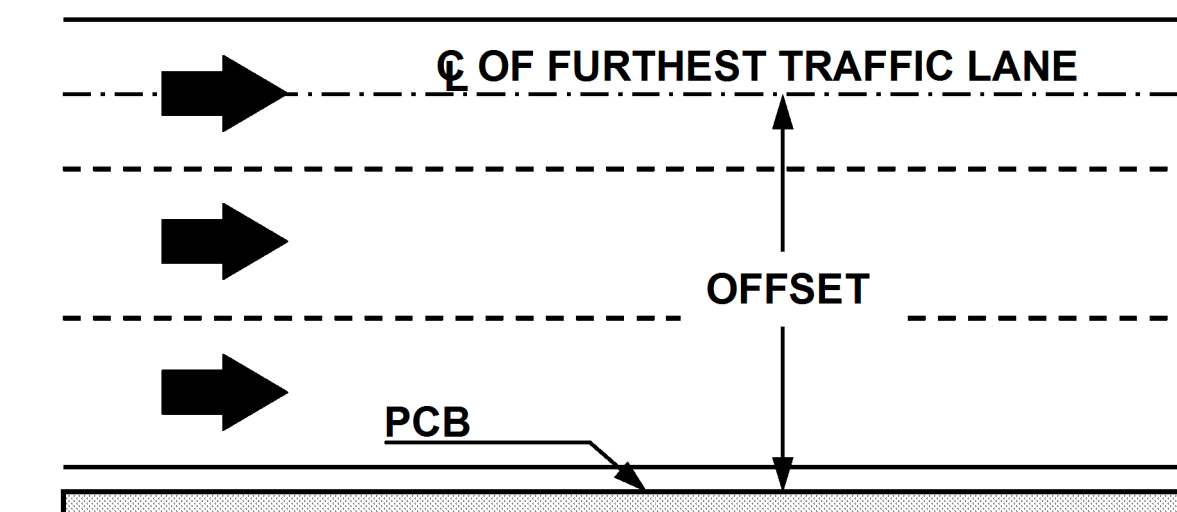

FIGURE B

APPROVED: <i>J. W. Woolard, Jr.</i> DATE: 10/6/2015 SEAL			PORTABLE CONCRETE BARRIER AT TEMPORARY SHORING LOCATIONS
--	--	--	---

Shoring Location No. 1

FOR TEMPORARY SHORING AND POSITIVE PROTECTION FOR TEMPORARY SHORING, SEE PLANS AND TEMPORARY SHORING PROVISION. BEFORE BEGINNING TEMPORARY SHORING DESIGN OR CONSTRUCTION, SURVEY EXISTING GROUND ELEVATIONS IN THE VICINITY OF SHORING LOCATIONS TO DETERMINE ACTUAL SHORING HEIGHTS.

DESIGN TEMPORARY SHORING FROM STATION 20+95 -L-, 23 FT RT., TO STATION 21+07 -L-, 28 FT RT., FOR THE FOLLOWING ASSUMED SOIL PARAMETERS AND WATER SURFACE ELEVATION:

WATER SURFACE = 757 FT (10-27-14)
 UNIT WEIGHT (γ) = 120 LB/CF
 FRICTION ANGLE (ϕ) = 30 DEGREES
 COHESION (c) = 0 LB/SF

LIMITED SUBSURFACE INFORMATION IS AVAILABLE IN THE VICINITY OF TEMPORARY SHORING FROM STATION 20+95 -L-, 23 FT RT., TO STATION 21+07 -L-, 28 FT RT. THE INFORMATION PROVIDED FOR TEMPORARY SHORING DESIGN WAS ASSUMED AND MAY NOT BE APPLICABLE TO THE ACTUAL SITE CONDITIONS ENCOUNTERED DURING CONSTRUCTION.

DRIVEN PILING FOR TEMPORARY SHORING FROM STATION 20+95 -L-, 23 FT RT., TO STATION 21+07 -L-, 28 FT RT. MAY NOT PENETRATE BELOW ELEVATION 714 FT DUE TO OBSTRUCTIONS, VERY DENSE OR HARD SOIL, BOULDERS OR WEATHERED OR HARD ROCK.

DO NOT USE A TEMPORARY WALL FOR TEMPORARY SHORING FROM STATION 20+95 -L-, 23 FT RT., TO STATION 21+07 -L-, 28 FT RT.

AT THE CONTRACTOR'S OPTION, USE STANDARD TEMPORARY SHORING FOR TEMPORARY SHORING FROM STATION 20+95 -L-, 23 FT RT, TO STATION 21+07 -L-, 28FT RT. SEE STANDARD DETAIL NO. 1801.01 FOR STANDARD TEMPORARY SHORING.

12/3/2015
 P:\TipProjects-B\B5142\Traffic\TrafficControl\TCP\B-5142_TC_TMP_1E.dgn
 User:rmgarratt

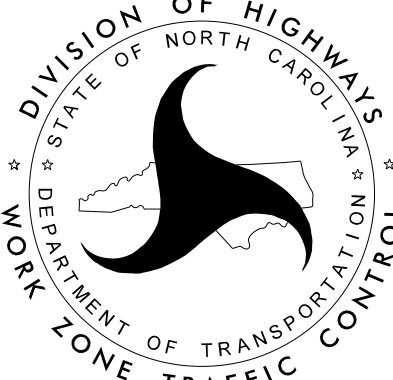
APPROVED: <u>Shane C. Clark</u> <small>1F4E87E60AD6EA</small> DATE: 12/3/2015 SEAL		 <p>TEMPORARY SHORING NOTES</p>
---	---	--

PHASING

PROJ. REFERENCE NO.	SHEET NO.
B-5142	TMP-2

PHASE I

- STEP 1: USING ROADWAY STANDARD DRAWING (RSD) 1101.01, SHEET 3 OF 3, INSTALL ADVANCED WORK ZONE WARNING SIGNS ON EXISTING SR 1302 (CORNELIUS RD) AND INTERSECTING -Y- LINES.
- STEP 2: USING TMP-3, TMP-3A, TMP-4, ROADWAY PLANS, STRUCTURES PLANS, AND RSD 1101.02, SHEET 1 OF 15 AS NECESSARY:
- PLACE TEMPORARY SHORING AND CONSTRUCT PROPOSED BRIDGE NO. 54.
 - CONSTRUCT FULL-WIDTH ROADWAY FROM -L- STA. 16+53± TO -L- STA. 27+00± UP TO, BUT NOT INCLUDING, FINAL LAYER OF SURFACE COURSE. CONSTRUCT WITHOUT SHOULDER BERM GUTTER AND GUARDRAIL ALONG THE RIGHT SIDE OF -L-.
 - WHILE MAINTAINING EXISTING DRAINAGE, CONSTRUCT AS MUCH OF -L- FROM STA. 14+00± TO STA. 16+53±; AND FROM STA. 27+00± TO STA. 29+75± UP TO, BUT NOT INCLUDING, FINAL LAYER OF SURFACE COURSE.
 - CONSTRUCT GUARDRAIL ALONG -L- FROM STA. 18+31±,LT., TO -L- STA. 28+32±,LT.
 - CONSTRUCT PROPOSED -Y3- FROM -L- TO -Y3- STA. 10+17±.
 - WIDEN -L- FROM STA. 10+00± TO STA. 14+00± UP TO, BUT NOT INCLUDING, FINAL LAYER OF SURFACE COURSE.
 - WIDEN -L- FROM STA. 29+75± TO STA. 33+38± UP TO, BUT NOT INCLUDING, FINAL LAYER OF SURFACE COURSE.
 - CONSTRUCT TEMPORARY PAVEMENT FROM -Y3- TO -L- STA. 34+00±.
 - WEDGE AND WIDEN -Y1- FROM STA. 11+00± TO STA. 11+76± TO PROPOSED ELEVATION UP TO, BUT NOT INCLUDING, FINAL LAYER OF SURFACE COURSE. USE TEMPORARY WEDGING OR FILL TO MAINTAIN ACCESS TO -Y1- FROM EXISTING SR 1302.

PLACE TEMPORARY PAVEMENT MARKINGS ON CONSTRUCTED SECTIONS AS SHOWN ON TMP-5 AND TMP-6. REPLACE MARKINGS ON WEDGED LOCATIONS.

- STEP 3: IN A CONTINUOUS MANNER USING TMP-5, TMP-6, ROADWAY PLANS, AND RSD 1101.02, SHEET 1 OF 15 AS NECESSARY:
- A) WEDGE FROM -L- STA. 10+00± TO -L- STA. 13+00± AND FROM -L- STA. 28+30± TO -L- STA. 33+38± UP TO, BUT NOT INCLUDING, FINAL LAYER OF SURFACE COURSE. WEDGE AS MUCH OF EXISTING SR 1302 TO CONSTRUCT A MINIMUM 15' WIDTH TIE-IN TO PROPOSED ROADWAY ELEVATION WHILE MAINTAINING A TWO-LANE TWO-WAY TRAFFIC PATTERN AT THE END OF EACH WORK DAY.
- B) PLACE TEMPORARY PAVEMENT MARKINGS AND PORTABLE CONCRETE BARRIER AS SHOWN ON TMP-7 AND TMP-8.

PHASE I, CONTINUED

COMPLETE PHASE I, STEP 4, BETWEEN THURSDAY, 7:00 P.M., AND MONDAY, 7:00 A.M. (SEE INTERMEDIATE CONTRACT TIMES AND LIQUIDATED DAMAGES)

- STEP 4: IN A CONTINUOUS MANNER USING TMP-7, TMP-8, AND ROADWAY PLANS:
- A) USING RSD 1101.02, SHEET 1 OF 15, INSTALL AND ACTIVATE PORTABLE TRAFFIC AND DRIVEWAY SIGNALS AND PLACE -L- INTO ONE-LANE, TWO-WAY TRAFFIC PATTERN. USE TEMPORARY DRIVEWAY AT -L- STA. 18+00± AND EXISTING SR 1302 TO MAINTAIN ACCESS TO -Y3-.
- B) - COMPLETE CONSTRUCTION OF A MINIMUM 26' WIDTH ROADWAY FROM -L- STA. 10+83± TO -L- STA. 13+88± UP TO, BUT NOT INCLUDING, FINAL LAYER OF SURFACE COURSE. WEDGE FULL WIDTH OF ROADWAY WITHOUT SHOULDERS AS SHOWN IN ROADWAY PLANS.
- COMPLETE CONSTRUCTION OF A MINIMUM 25' WIDTH ROADWAY FROM -L- STA. 28+46± TO -L- STA. 31+50± UP TO, BUT NOT INCLUDING, FINAL LAYER OF SURFACE COURSE. WEDGE FULL WIDTH OF ROADWAY WITHOUT SHOULDERS AS SHOWN IN ROADWAY PLANS.
- CONSTRUCT -Y2- FROM STA. 10+51± TO STA. 11+00±. PLACE TEMPORARY WEDGING ALONG EXISTING SR 1302 TO ALLOW ACCESS ONTO -Y2-.
- C) WEDGE FULL WIDTH OF ROADWAY AND CONSTRUCT SHOULDER FROM -L- STA. 10+00± TO -L- STA. 10+88±; AND FROM -L- STA. 31+50± TO -L- STA. 33+39± UP TO, BUT NOT INCLUDING, FINAL LAYER OF SURFACE COURSE.
- D) PLACE TEMPORARY PAVEMENT MARKINGS AND PORTABLE CONCRETE BARRIER ALONG -L- AS SHOWN ON TMP-9 AND TMP-10.
- E) OPEN -L- TO TWO-LANE, TWO-WAY TRAFFIC AND SHIFT ACCESS TO EXISTING SR 1302 VIA -Y2-. DEACTIVATE AND REMOVE PORTABLE TRAFFIC AND DRIVEWAY SIGNALS.



PHASE II

- STEP 1: USING TMP-9, TMP-10, ROADWAY PLANS AND RSD 1101.02, SHEET 1 OF 15 AS NECESSARY:
- COMPLETE CONSTRUCTION OF -L- ROADWAY AND SHOULDER FROM STA. 13+88± TO STA. 17+29±, AND FROM STA. 26+21± TO STA. 29+75±, UP TO BUT NOT INCLUDING FINAL LAYER OF SURFACE COURSE.
 - CONSTRUCT SHOULDER BERM-AND-GUTTER WITH GUARDRAIL AND DRAINAGE COMPONENTS FROM -L- STA. 17+29±,RT., TO -L- STA. 25+43±,RT.
- STEP 2: USING TMP-10 AND ROADWAY PLANS:
- A) USING RSD 1101.02, SHEET 1 OF 15, PLACE WATER-FILLED BARRIER ALONG EXISTING SR 1302 AND -Y3- AND PLACE INTO ONE-LANE, TWO-WAY TRAFFIC PATTERN.
- B) CONSTRUCT -Y3- FROM STA. 10+19±,LT., TO STA. 11+45±,LT., UP TO, BUT NOT INCLUDING, FINAL LAYER OF SURFACE COURSE.

PHASE III

- STEP 1: USING TMP-11, TMP-12, ROADWAY PLANS, AND RSD 1101.02, SHEET 1 OF 15 AS NECESSARY:
- A) PLACE TEMPORARY PAVEMENT MARKINGS AS SHOWN ON FINAL PAVEMENT MARKING PLANS. REMOVE PORTABLE CONCRETE BARRIER FROM -L- STA. 19+00± TO -L- STA. 25+00±.
- B) OPEN CONSTRUCTED -Y3- TO ONE-LANE, TWO-WAY TRAFFIC PATTERN AND CLOSE EXISTING SR 1302 TO TRAFFIC.
- STEP 2: - CONSTRUCT -Y3- FROM STA. 10+19±,RT., TO STA. 11+45±,RT., UP TO AND INCLUDING FINAL LAYER OF SURFACE COURSE.
- REMOVE EXISTING SR 1302 ROADWAY, STRUCTURE, AND SHORING. CONSTRUCT ALL REMAINING SHOULDER OF -Y2- AND PROPOSED DRAINAGE FACILITIES.
- STEP 3: USING ROADWAY PLANS AND FINAL PAVEMENT MARKING PLANS, PLACE FINAL LAYER OF SURFACE AND PERMANENT PAVEMENT MARKINGS.
- STEP 4: REMOVE LANE CLOSURE FROM -Y3-, REMOVE ALL WORK ZONE DEVICES, AND OPEN ALL ROADWAYS TO FINAL TRAFFIC PATTERN.

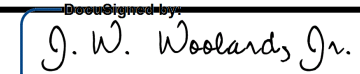
10/5/2015 P:\ip\projects-B\B5142\TrafficControl\CP\B-5142_TC_TMP-2.dgn User:shanson

APPROVED: 			<h1>PHASING</h1>
DATE: 10/6/2015			

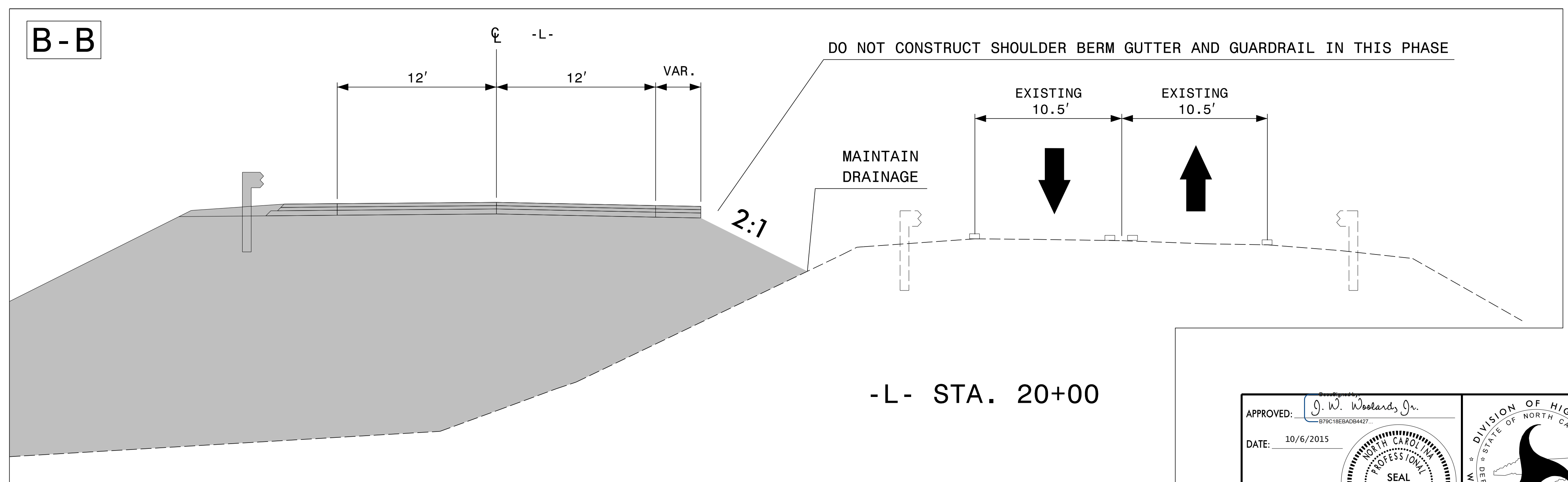
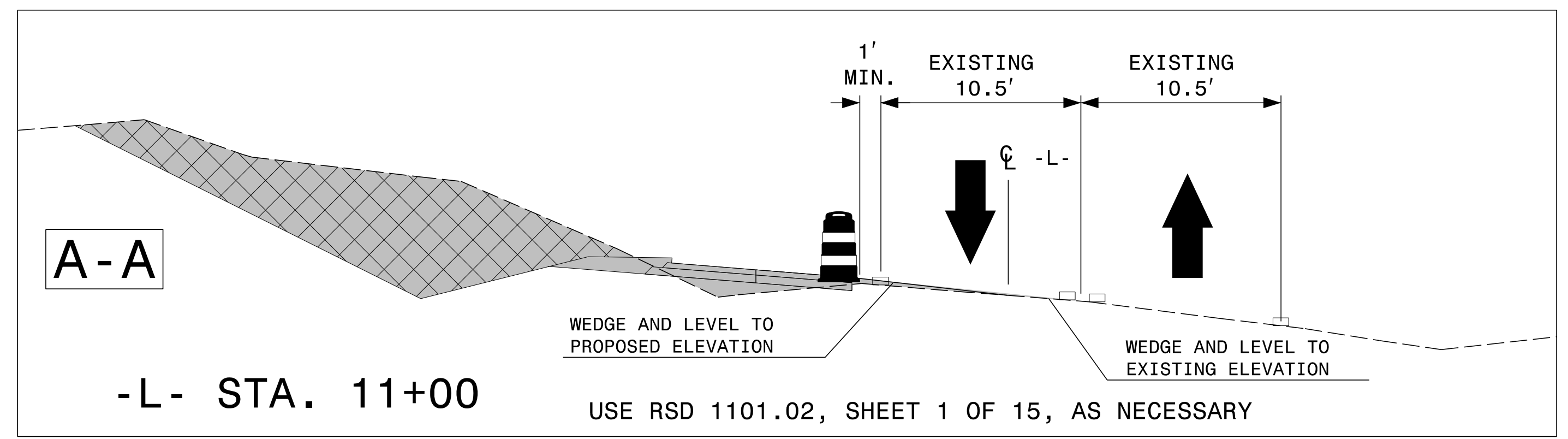
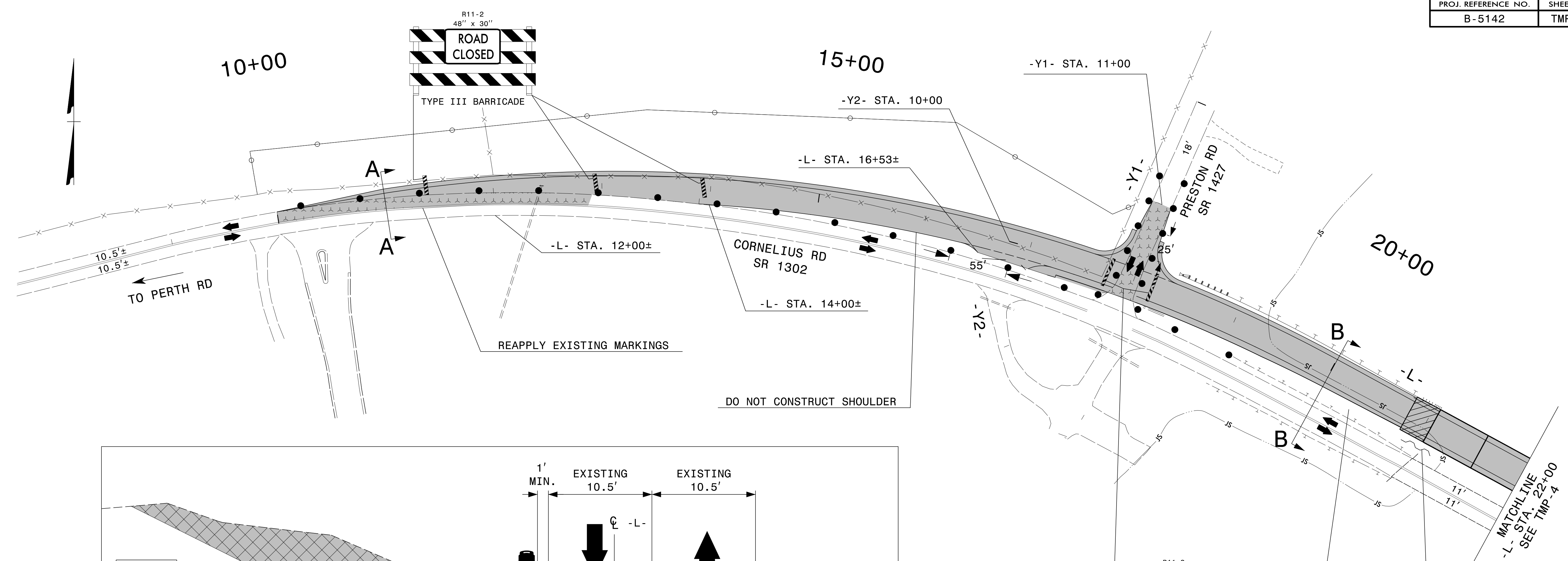

APPROVED: J. W. Woolard, Jr.
 DATE: 10/6/2015
 NORTH CAROLINA PROFESSIONAL SEAL 019862
 J. W. WOOLARD, INC.

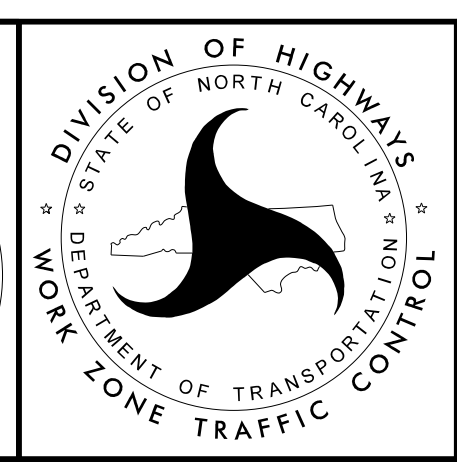

PHASE I
 STEP 2
 DETAIL

10/5/2015
 P:\TipProjects\B5142\TrafficControl\TCP\B-5142_TC_TMP_Plan.dgn
 User:shanson

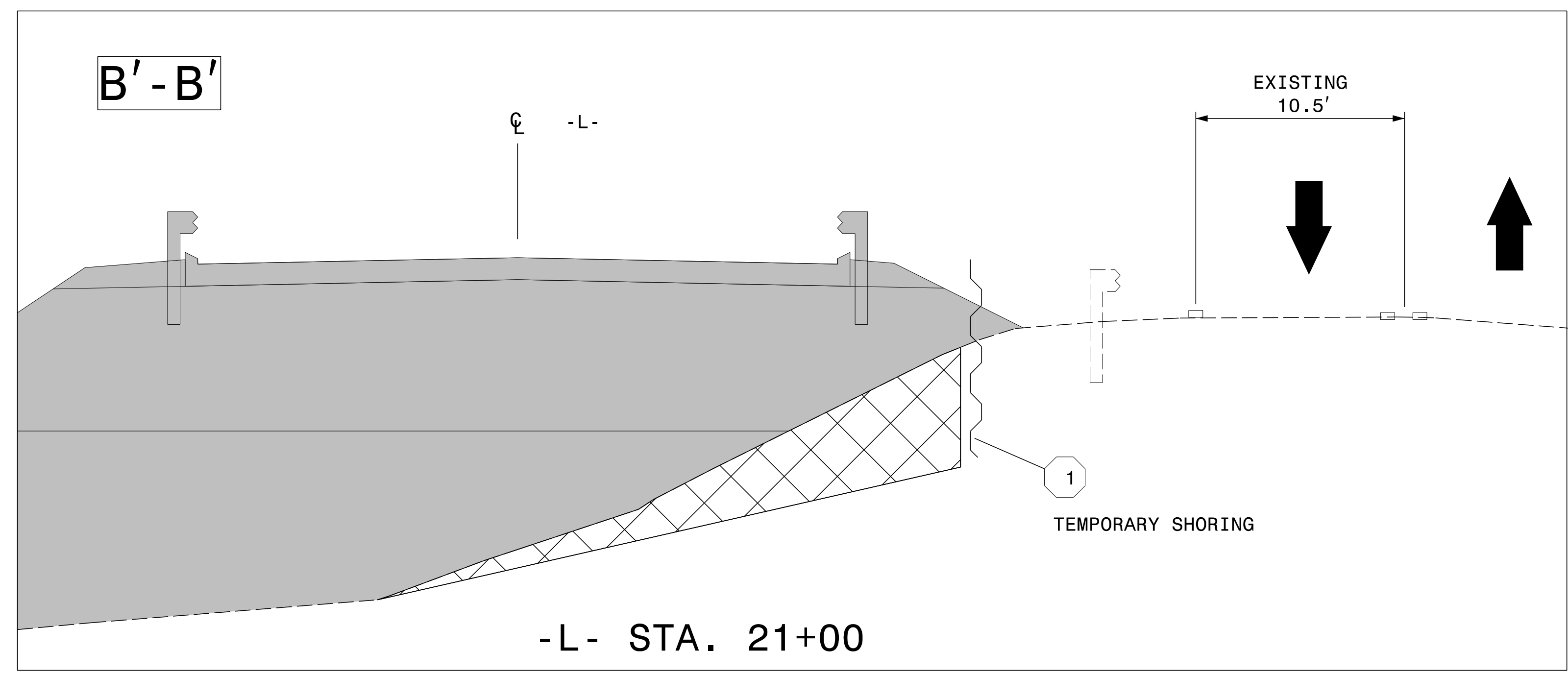
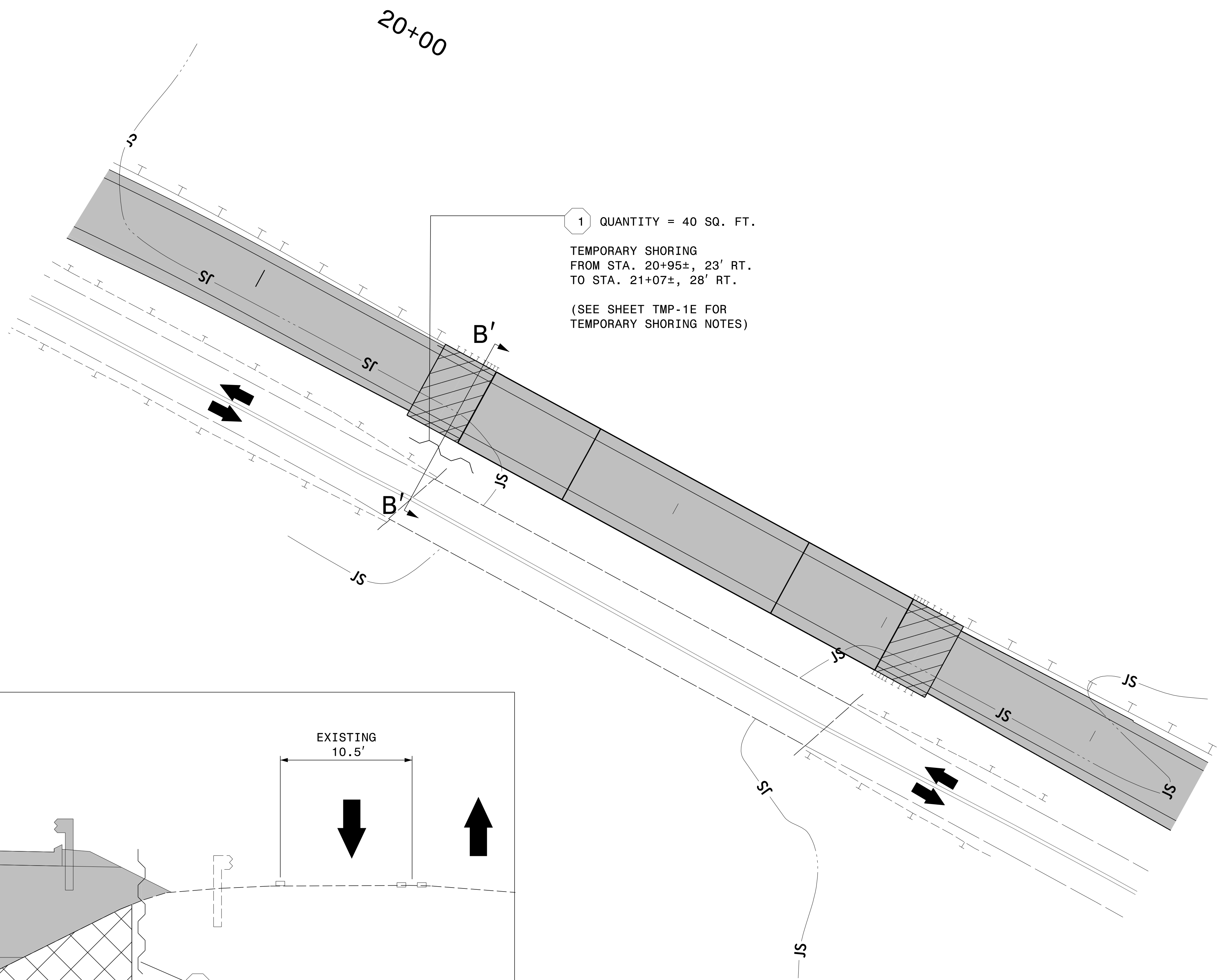
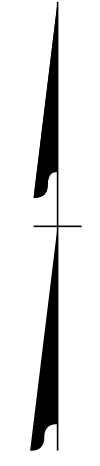

APPROVED: *J. W. Woolard, Jr.*
07918E8AD284427
 DATE: 10/14/2015

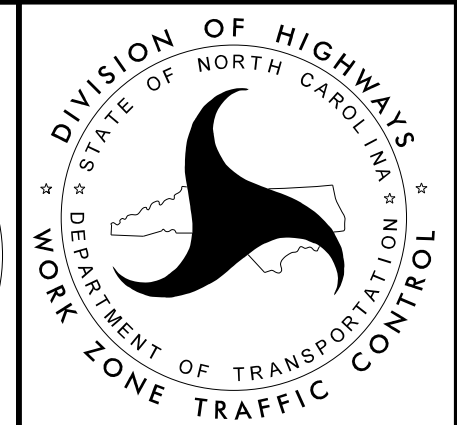
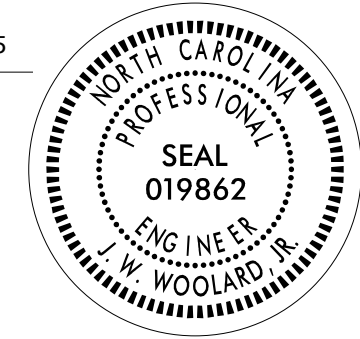

**PHASE I
SHORING
DETAIL**

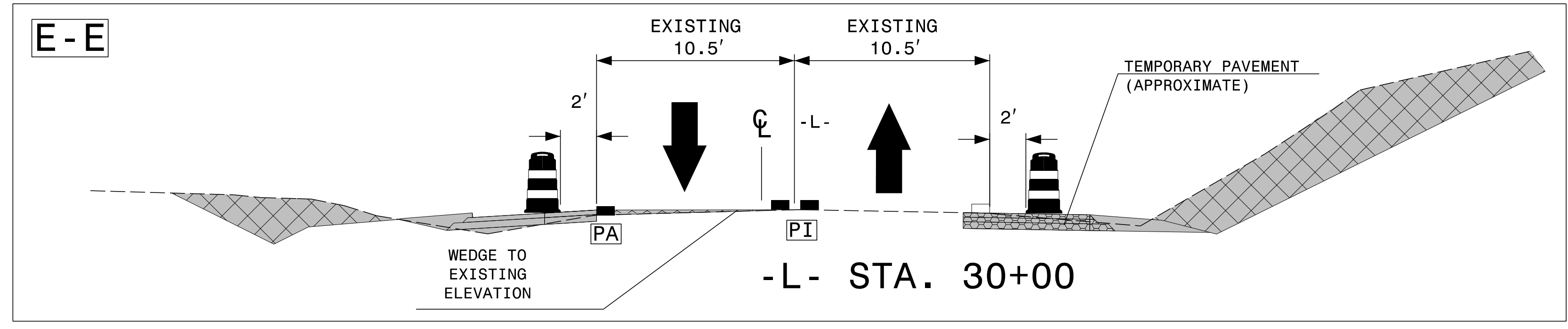
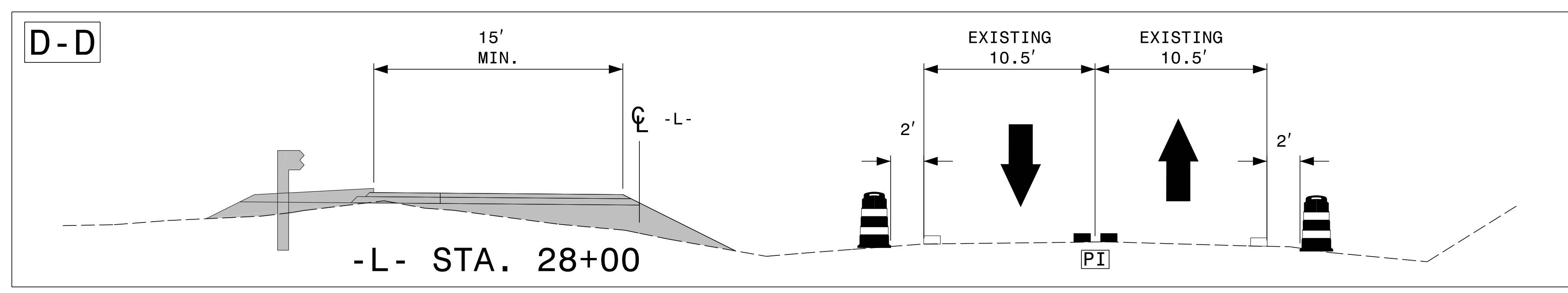
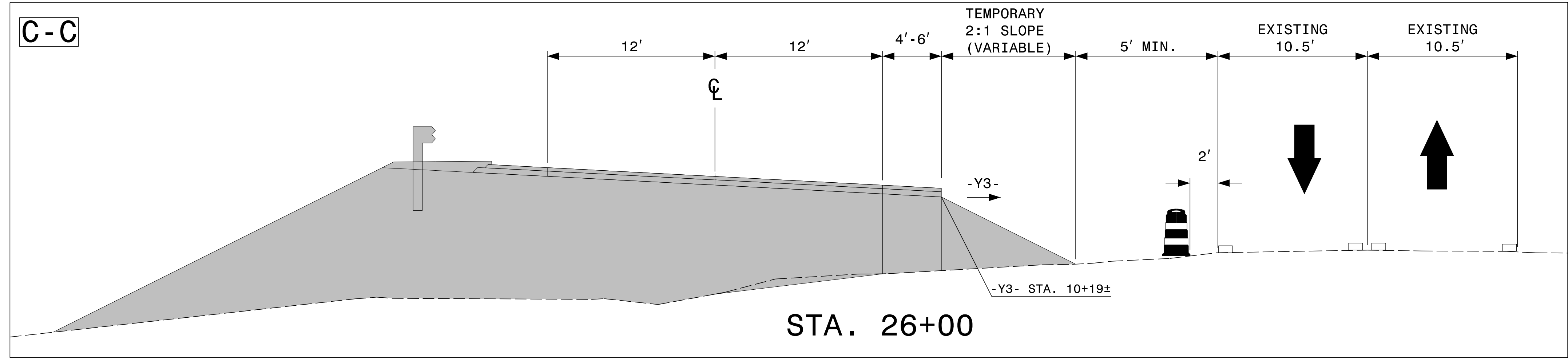
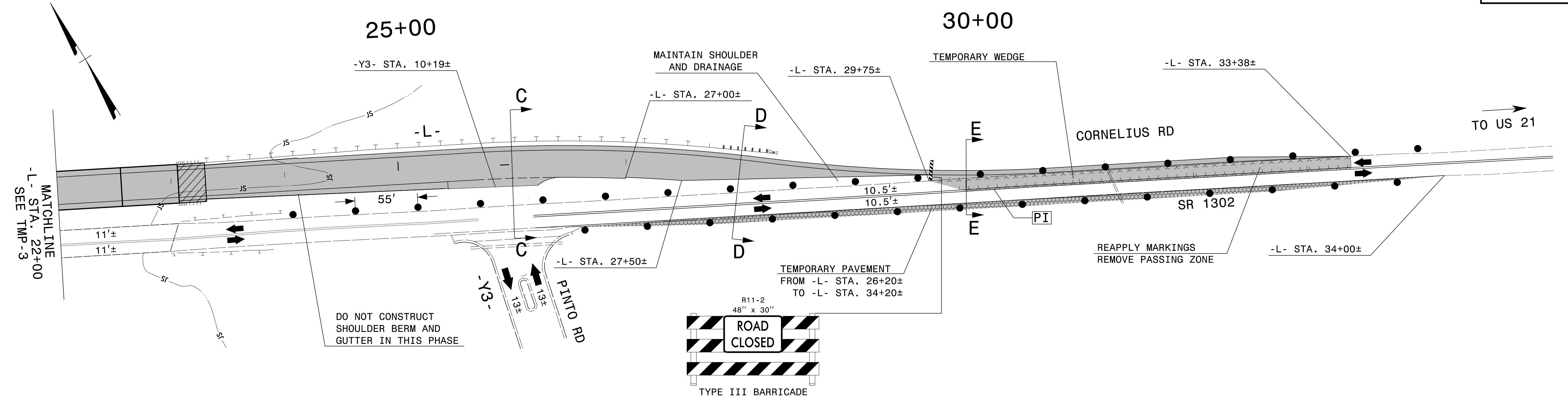

APPROVED: *J. W. Woolard, Jr.*
 DATE: 10/6/2015

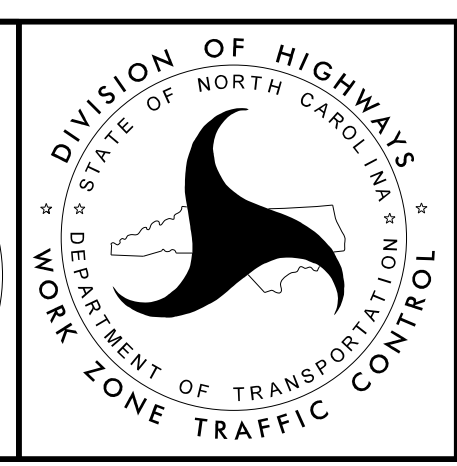

DIVISION OF HIGHWAYS
 STATE OF NORTH CAROLINA
 DEPARTMENT OF TRANSPORTATION
 WORK ZONE TRAFFIC CONTROL

**PHASE I
 STEP 2
 DETAIL**

10/5/2015
 P:\TIP\Projects-B\B5142\TrafficControl\TCP\B-5142_TC_TMP_Pla2.dgn
 User:shanson

SEE RSD 1101.02, SHEET 1 OF 15, FOR
FLAGGER, TAPER, AND BUFFER LOCATIONS

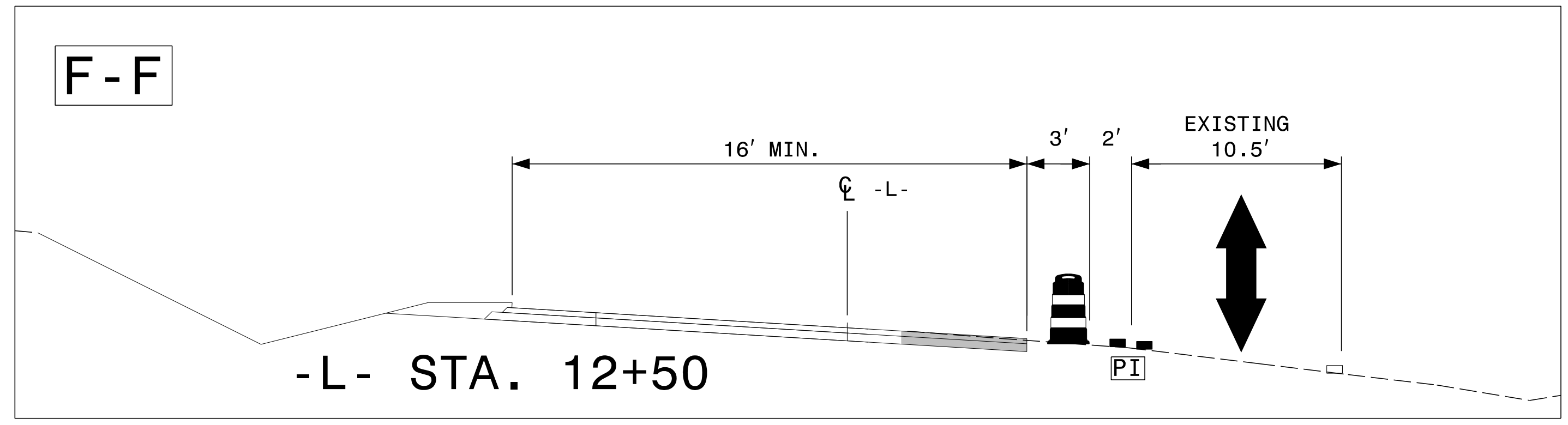
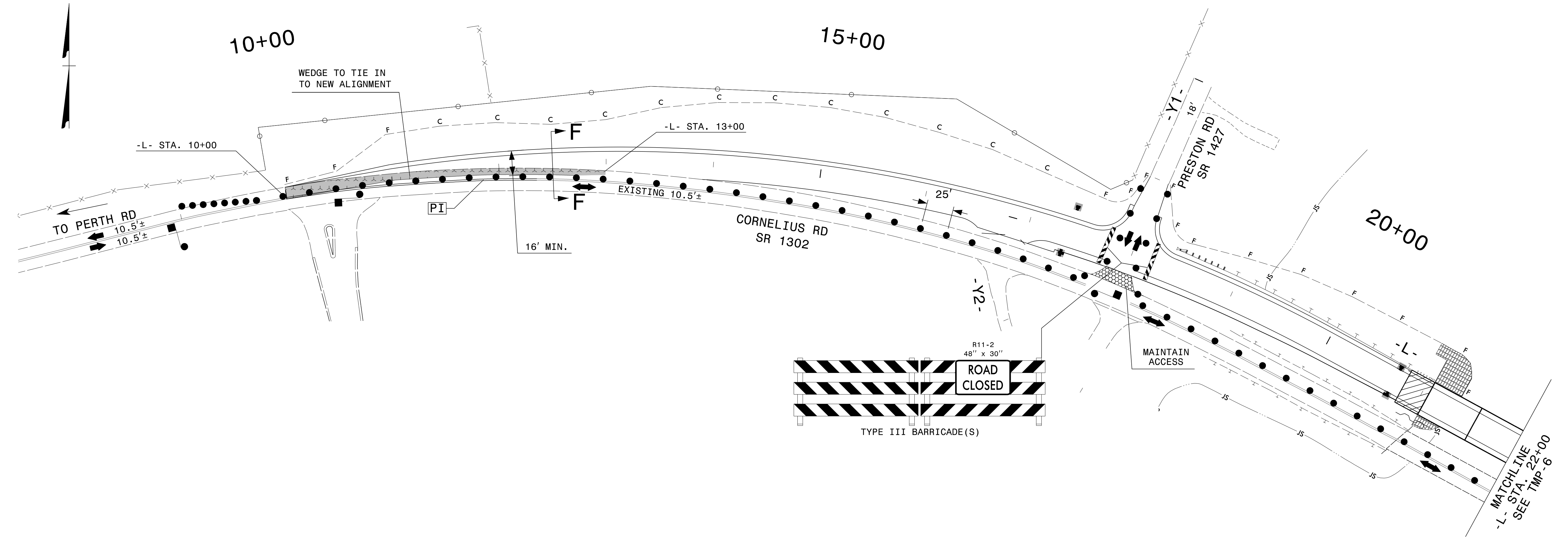

APPROVED: *J. W. Woolard, Jr.*
DATE: 10/6/2015

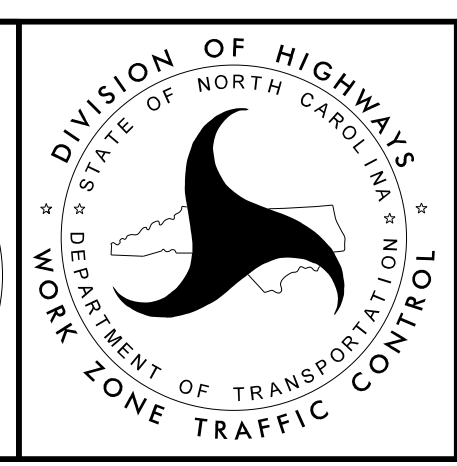

DIVISION OF HIGHWAYS
STATE OF NORTH CAROLINA
DEPARTMENT OF TRANSPORTATION
ZONE TRAFFIC CONTROL

**PHASE I
STEP 3
DETAIL**

10/5/2015
 P:\TipProjects\B-5142\TrafficControl\TCP\B-5142_TC_TMP_Pib1.dgn
 User: sfnasson

SEE RSD 1101.02, SHEET 1 OF 15, FOR
FLAGGER, TAPER, AND BUFFER LOCATIONS

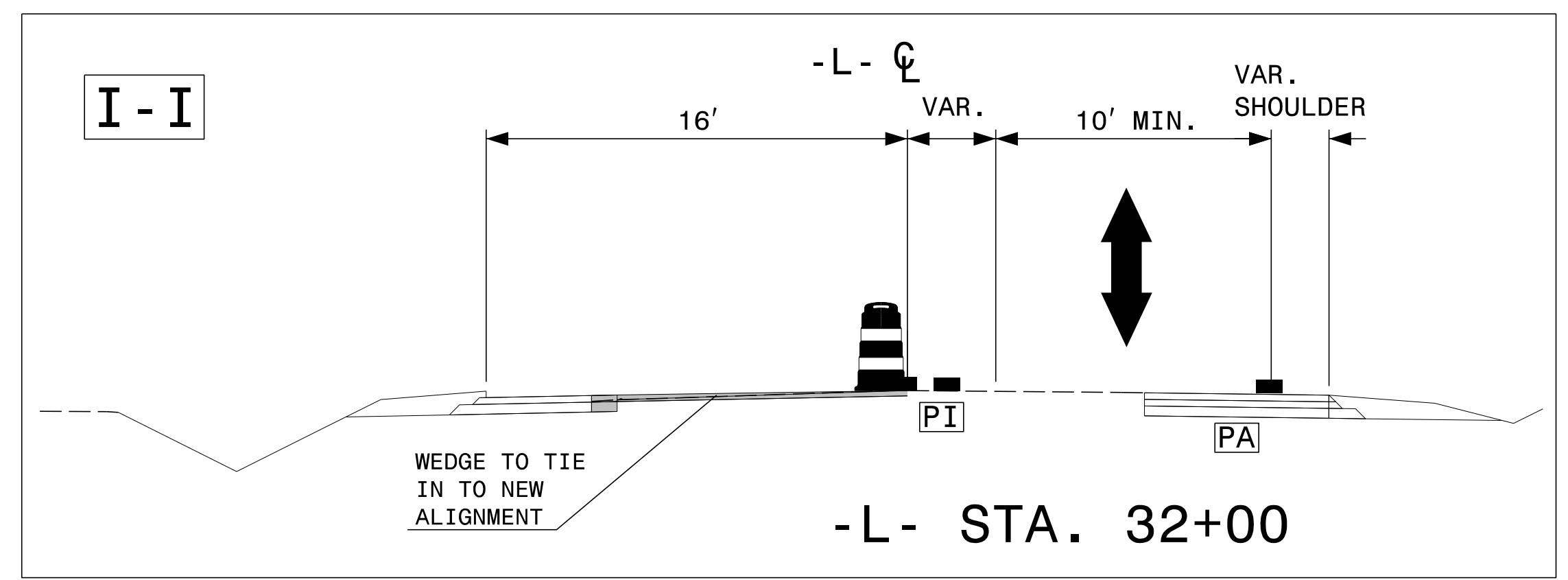
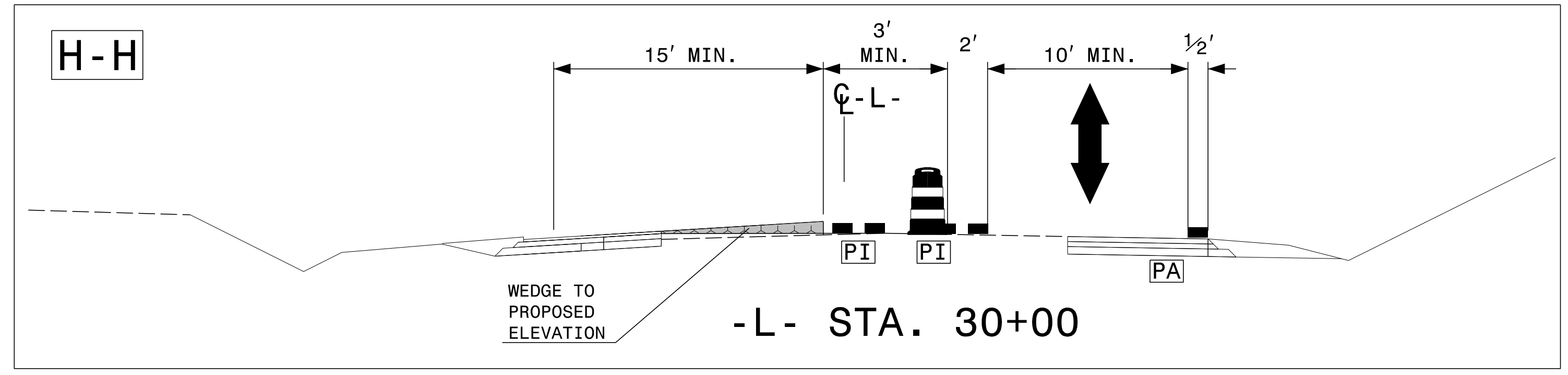
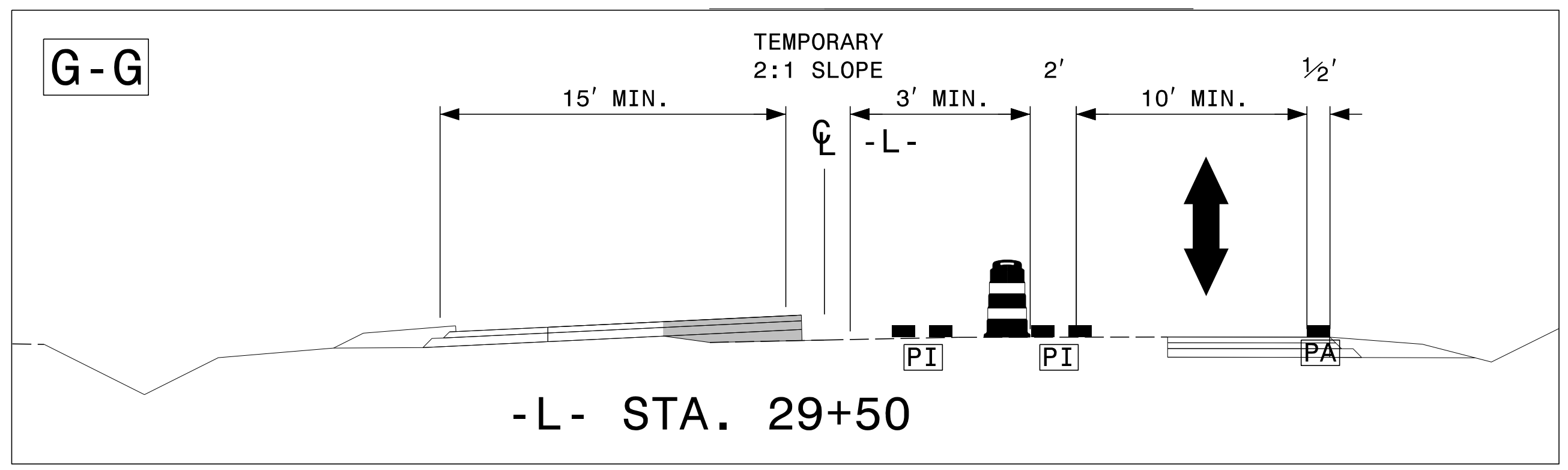
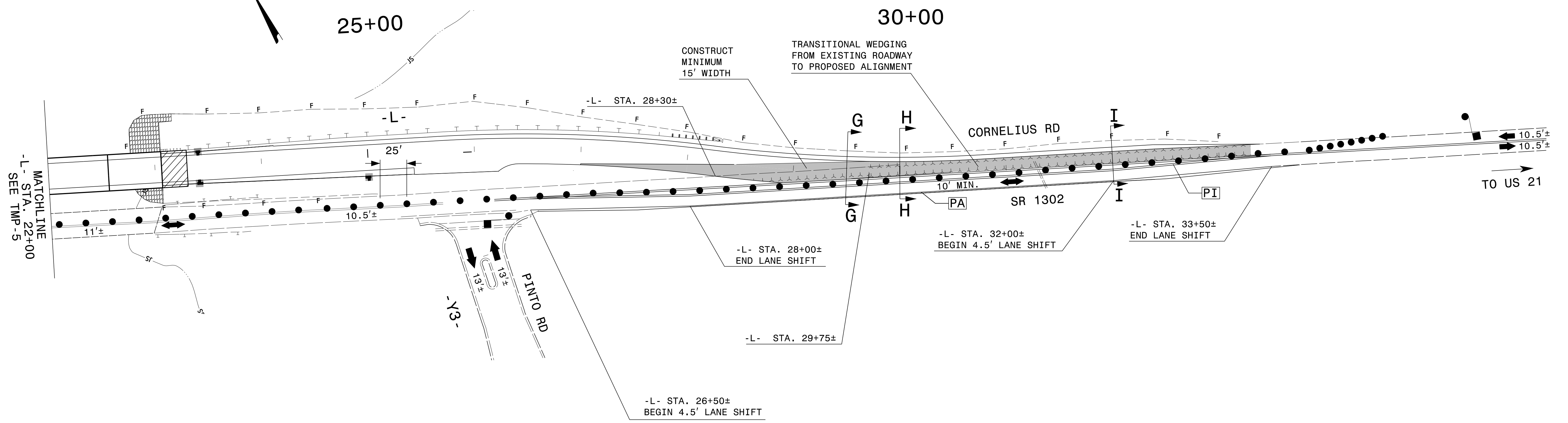

APPROVED: <i>J. W. Woolard, Jr.</i> DATE: 10/6/2015 		PHASE I STEP 3 DETAIL
--	--	--------------------------------------

10/5/2015
 P:\TipProjects\B-5142\TrafficControl\TCP\B-5142_TC_TMP_Pib2.dgn
 User:shanson

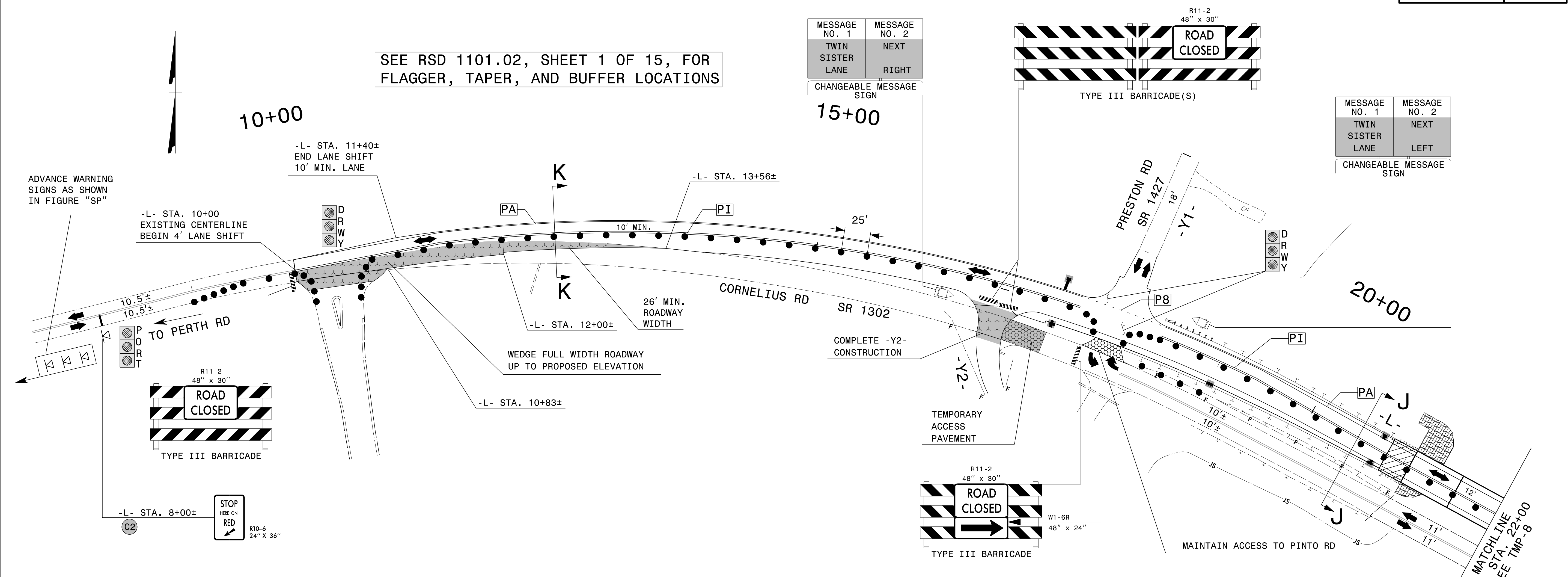

SEE RSD 1101.02, SHEET 1 OF 15, FOR
FLAGGER, TAPER, AND BUFFER LOCATIONS

MESSAGE NO. 1	MESSAGE NO. 2
TWIN SISTER LANE	NEXT RIGHT
CHANGEABLE MESSAGE SIGN	

MESSAGE NO. 1	MESSAGE NO. 2
TWIN SISTER LANE	NEXT LEFT
CHANGEABLE MESSAGE SIGN	

FIGURE "SP"

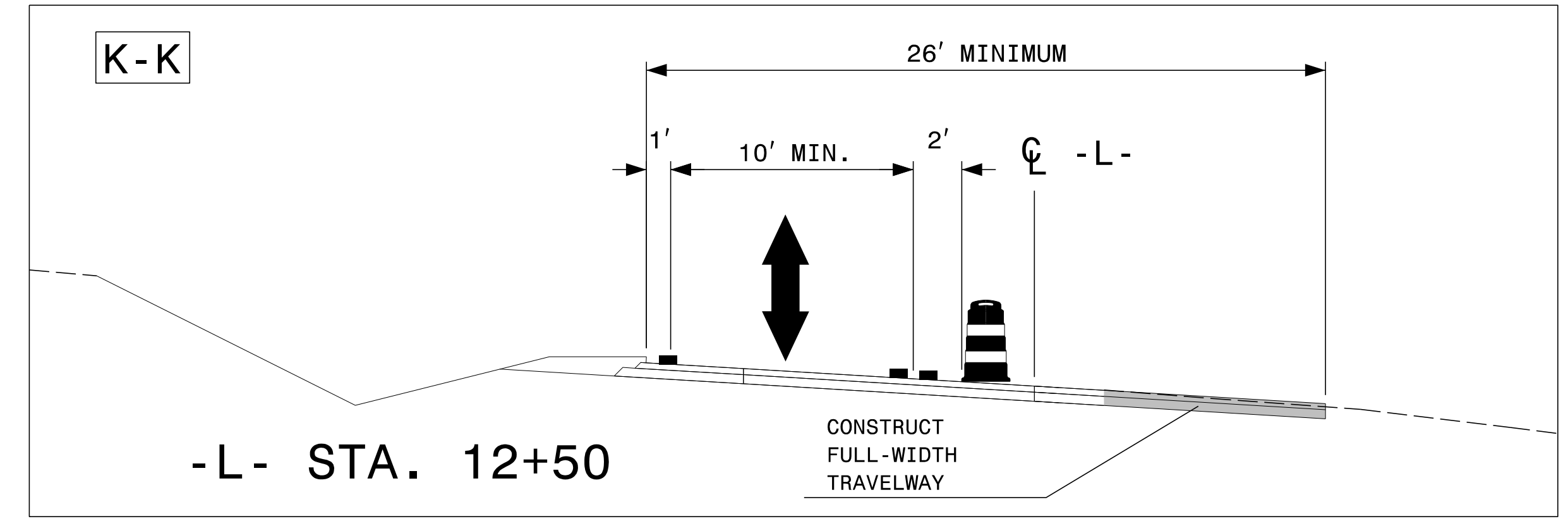
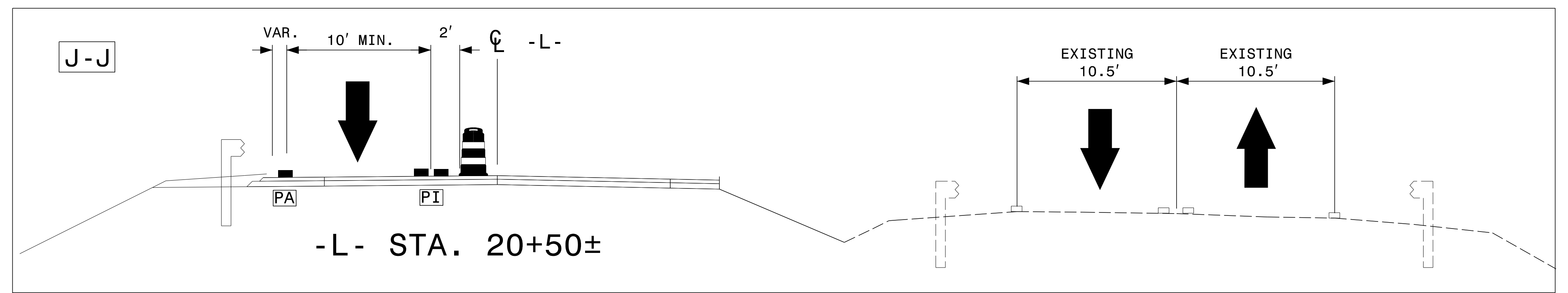
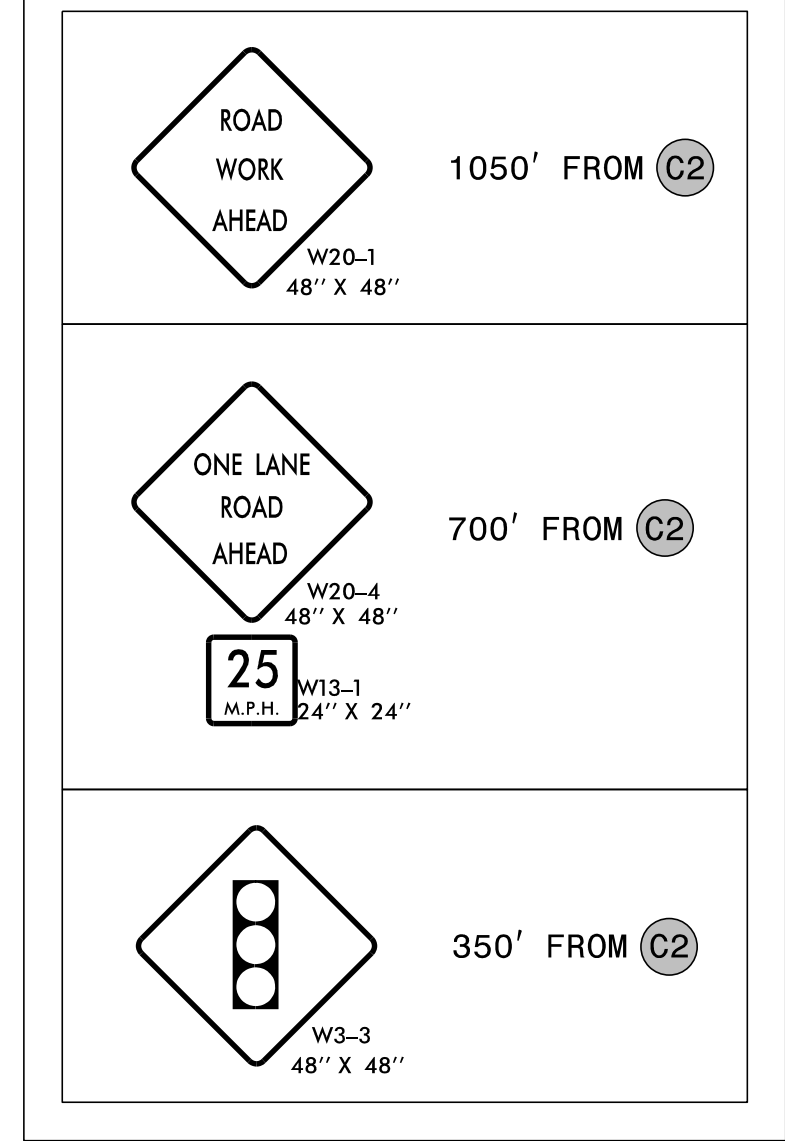

APPROVED: J. W. Woolard, Jr.
DATE: 10/6/2015

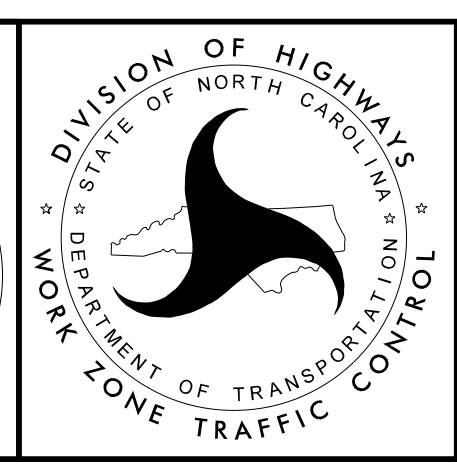
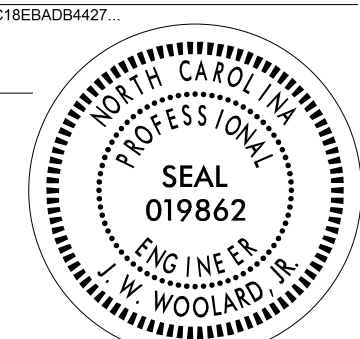

PHASE I
STEP 4
DETAIL

10/5/2015
P:\TIP\Projects-B\B5142\TrafficControl\CPN-B-5142-TC-TMP_P22.blgdn
User:shanson

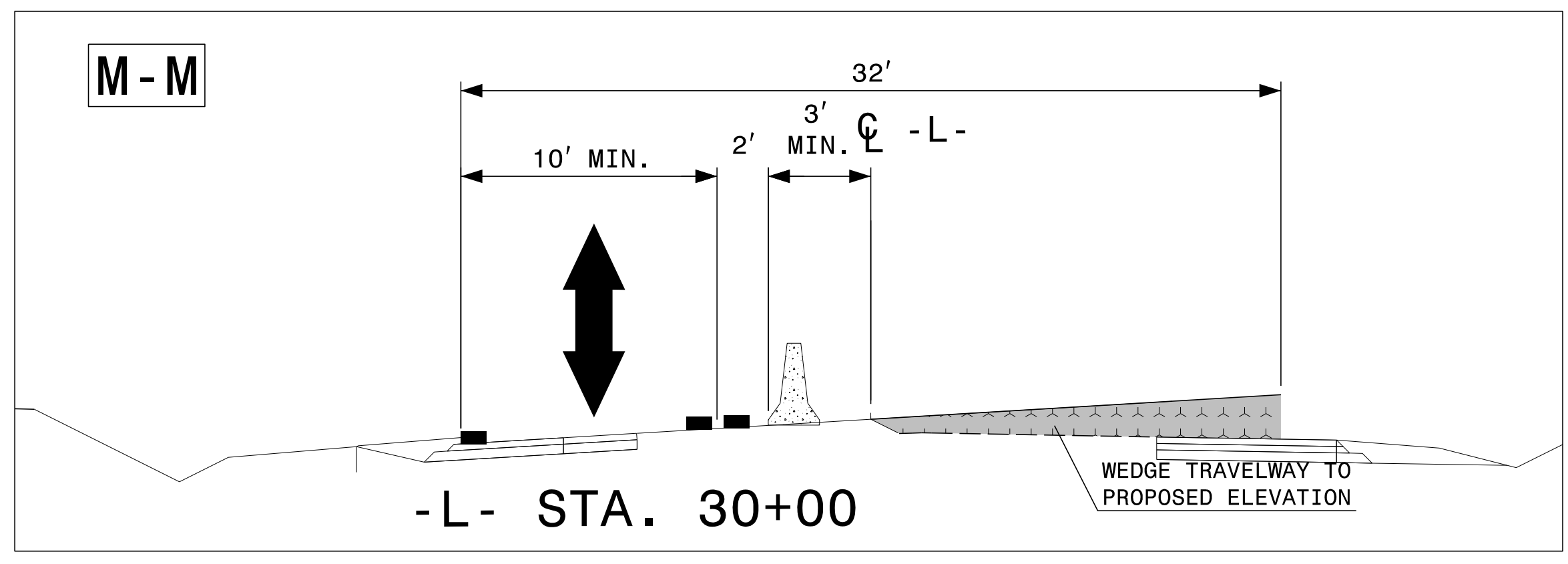
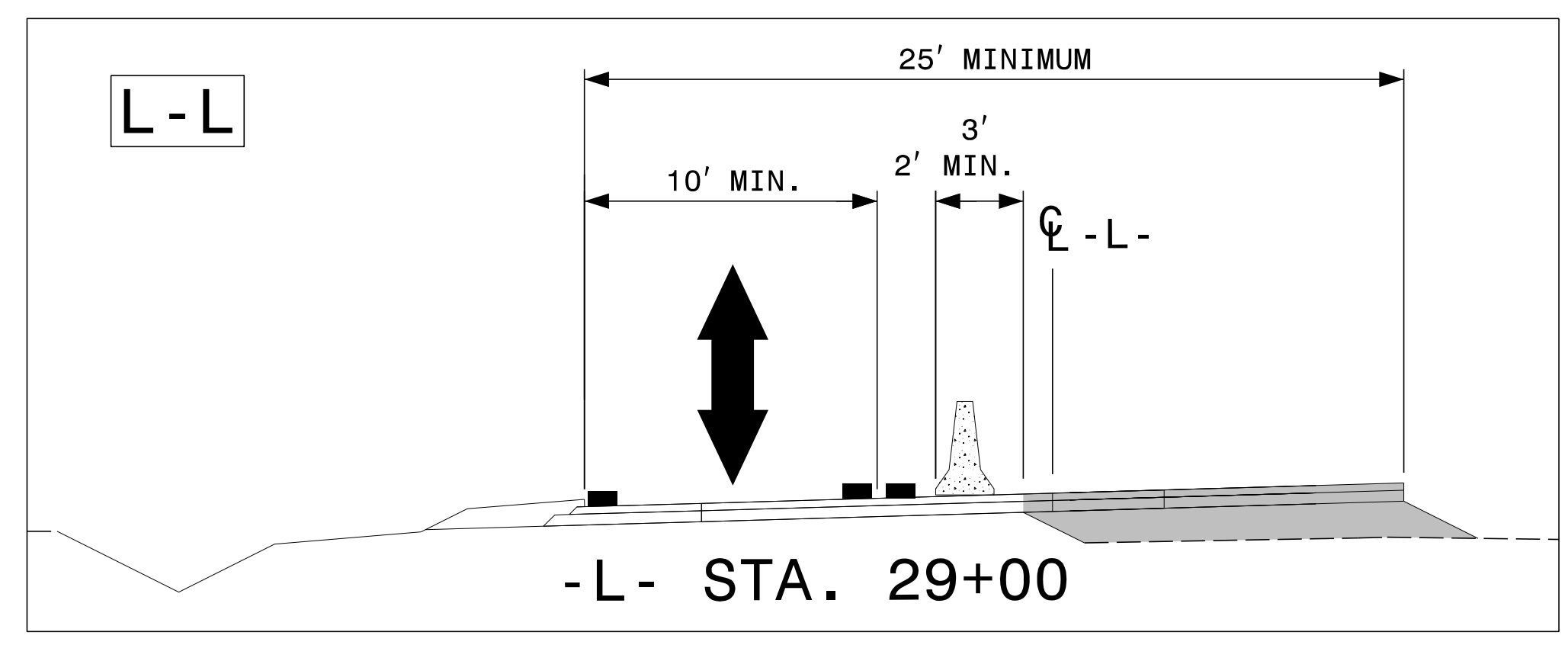
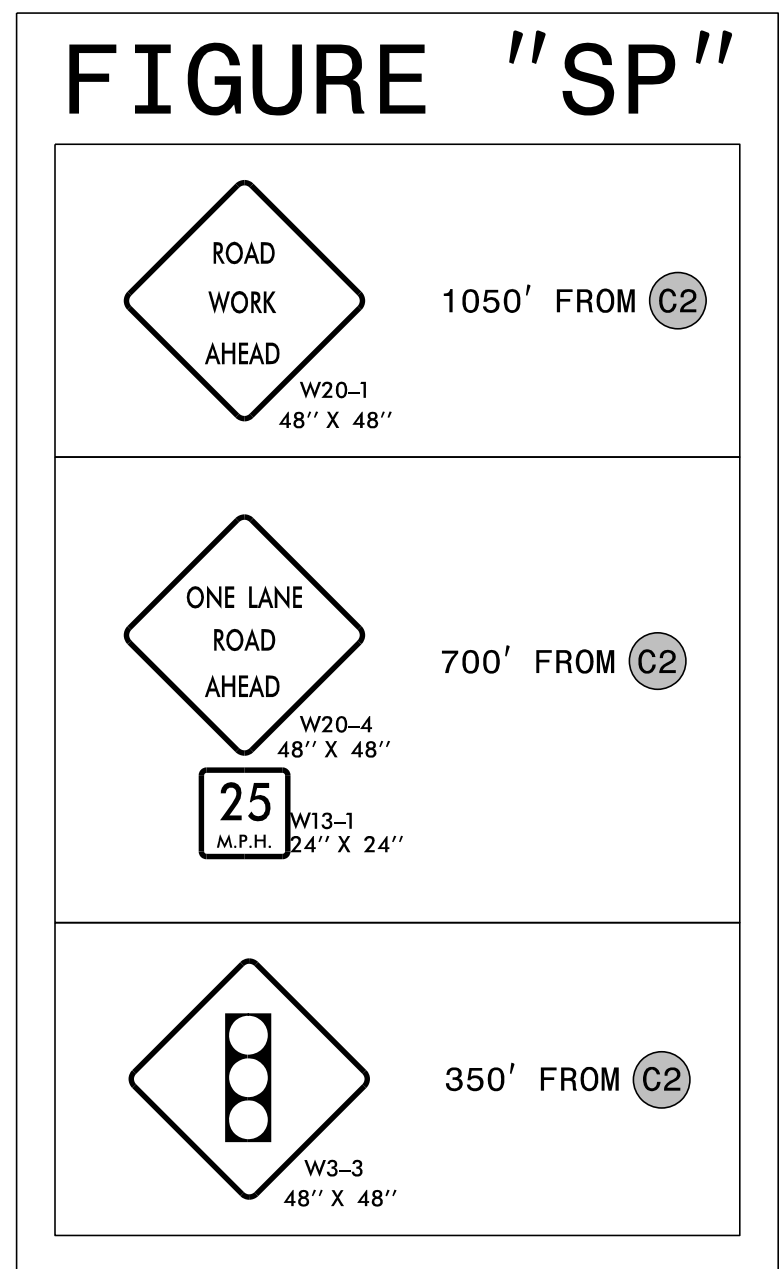
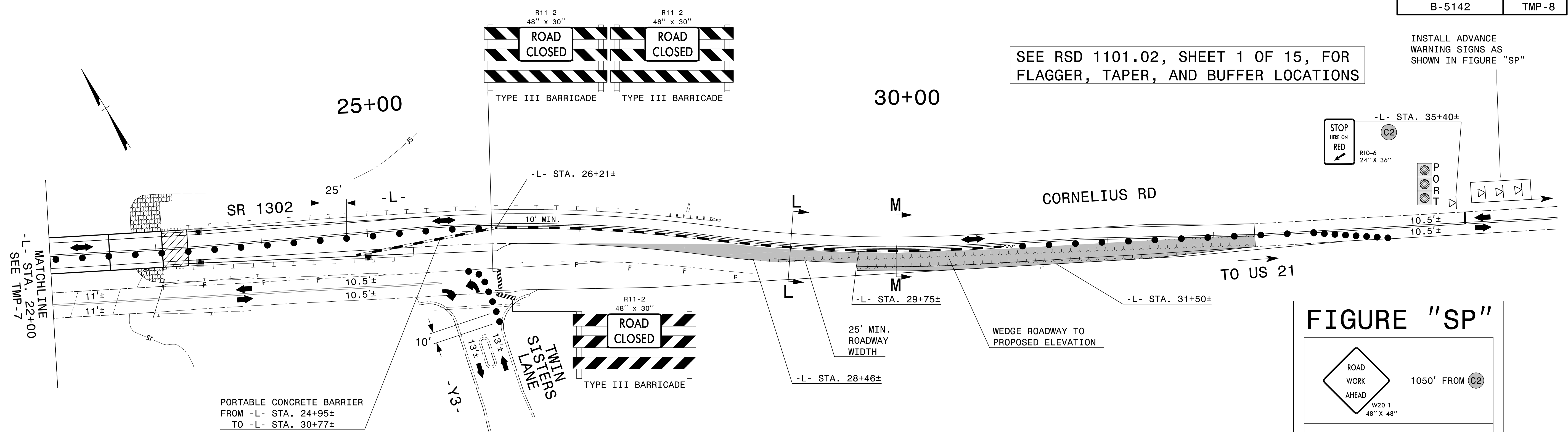

APPROVED: *J. W. Woolard, Jr.*

DATE: 10/6/2015

PROFESSIONAL SEAL 019862

ENGINEER J. W. WOOLARD, JR.

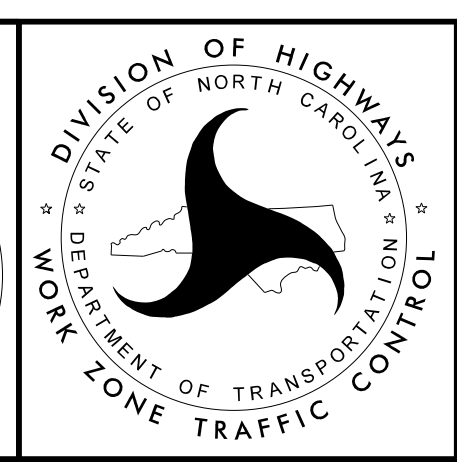

PHASE I
STEP 4
DETAIL

10/5/2015
 P:\TipProjects\B-5142\TrafficControl\TCP\B-5142_TC_TMP_P2b2.dgn
 User:shanson

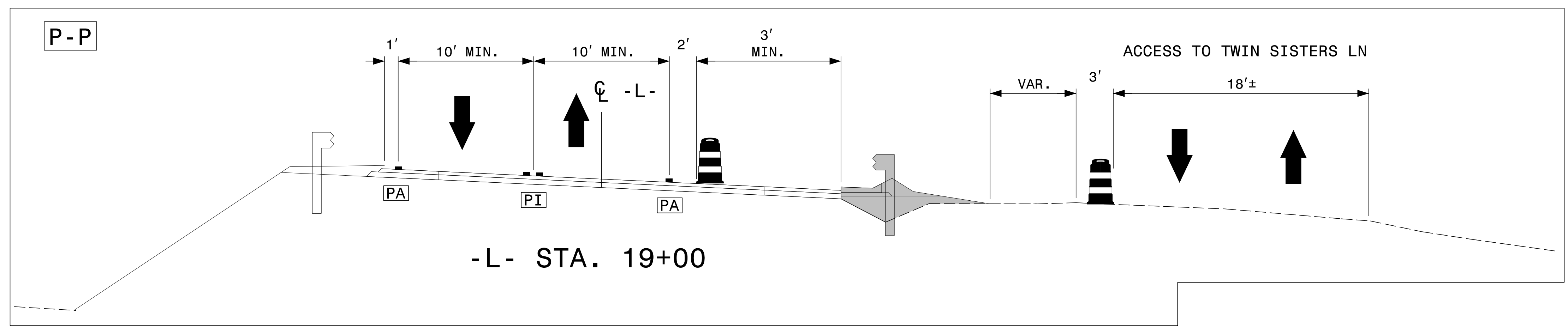
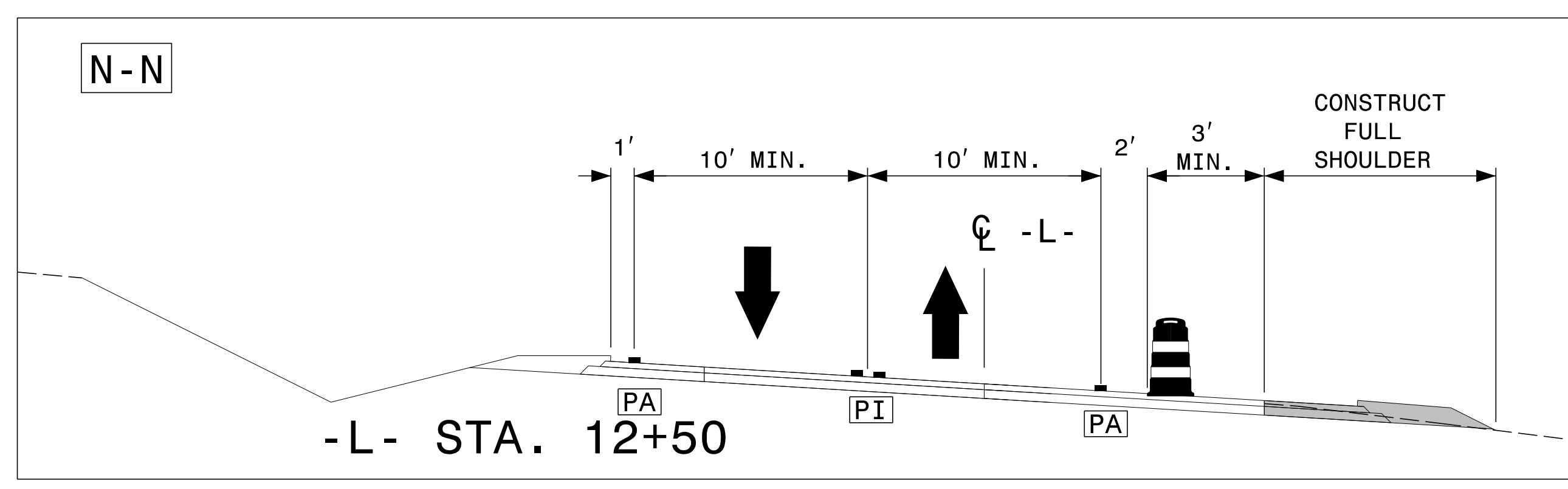
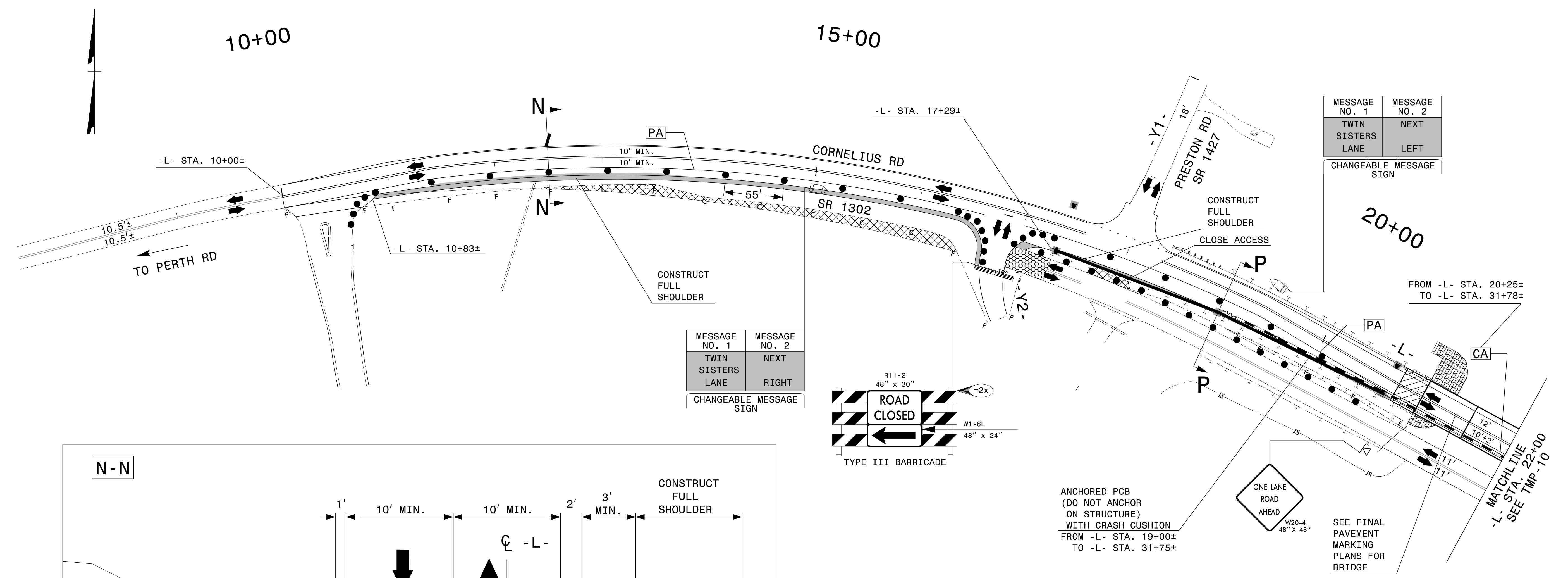

APPROVED: <i>J. W. Woolard, Jr.</i> DATE: 10/6/2015 		<p>PHASE II</p> <p>DETAIL</p>
--	--	---

10/5/2015
 P:\TIP\Projects-B\B5142\TrafficControl\TCP\B-5142_TC_TMP_P3-1.dgn
 User: shanson

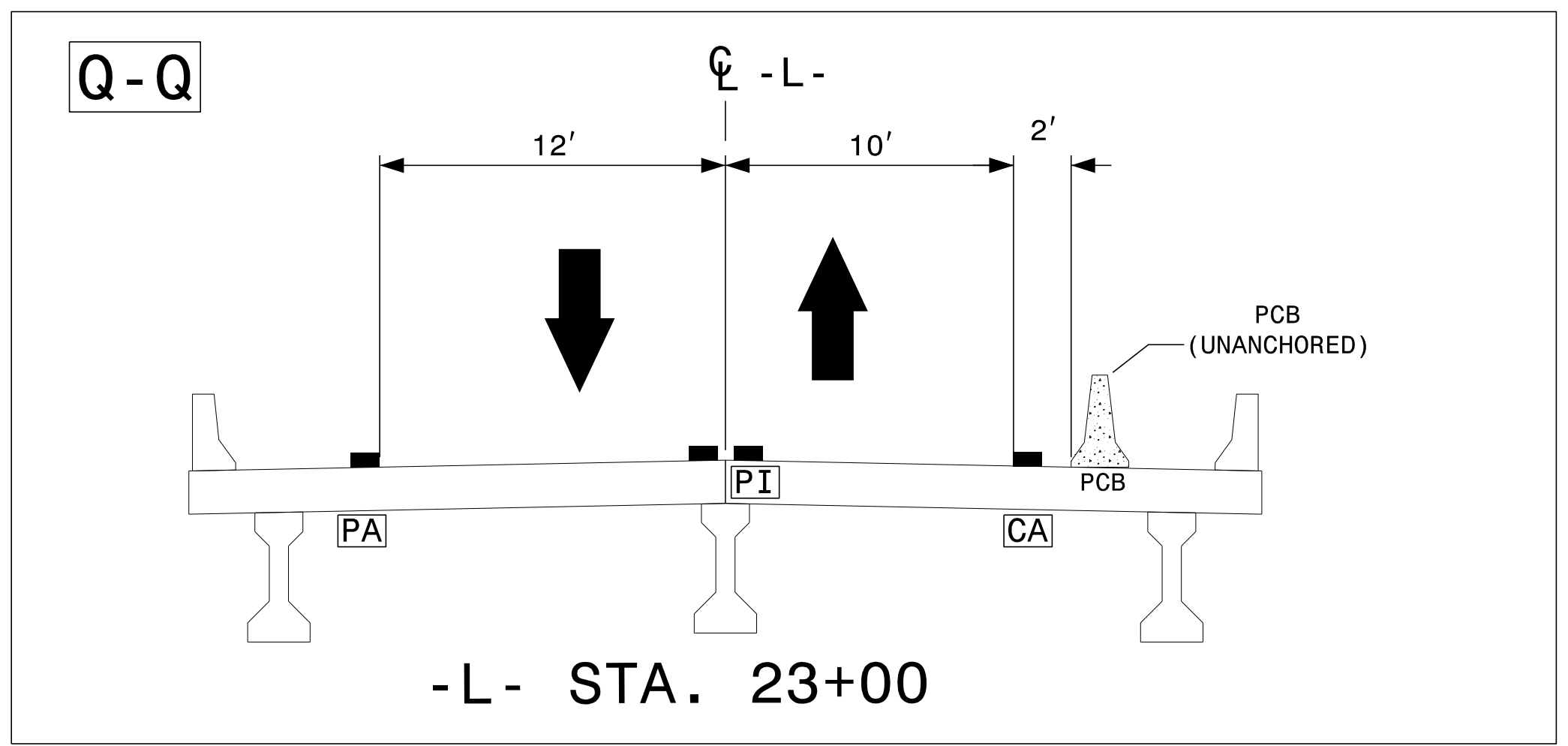
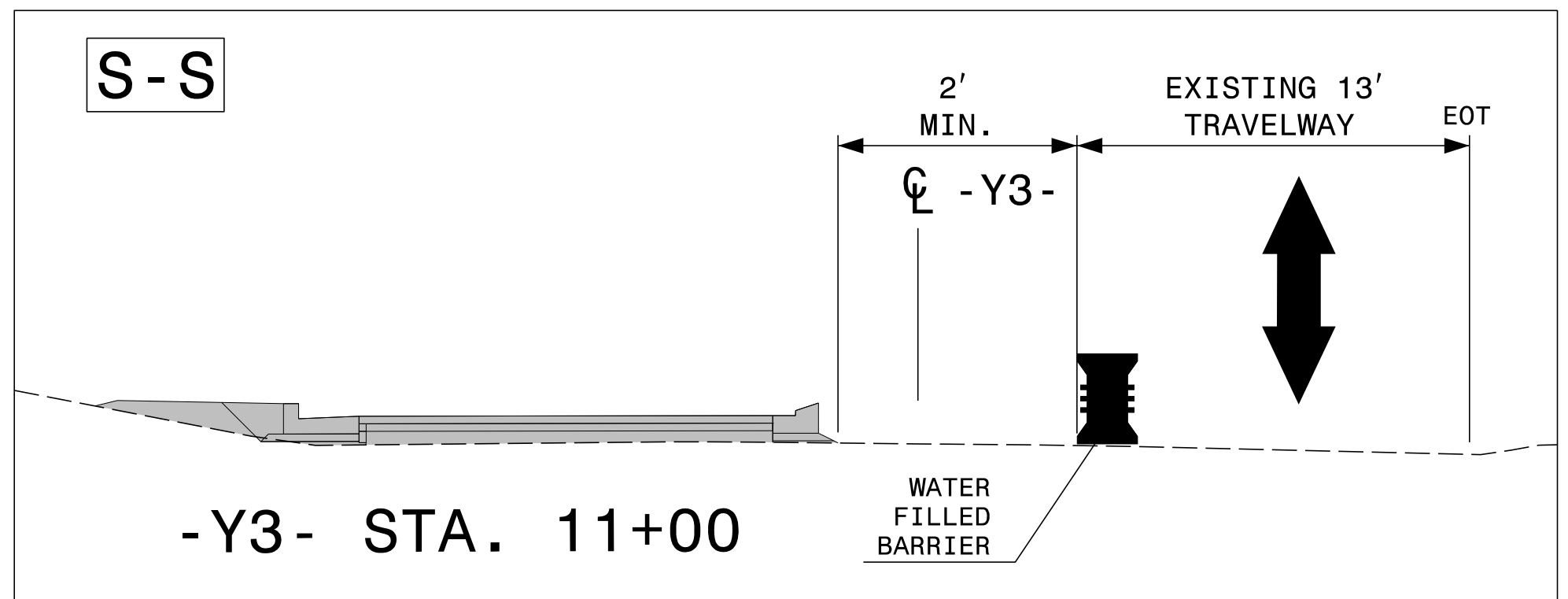
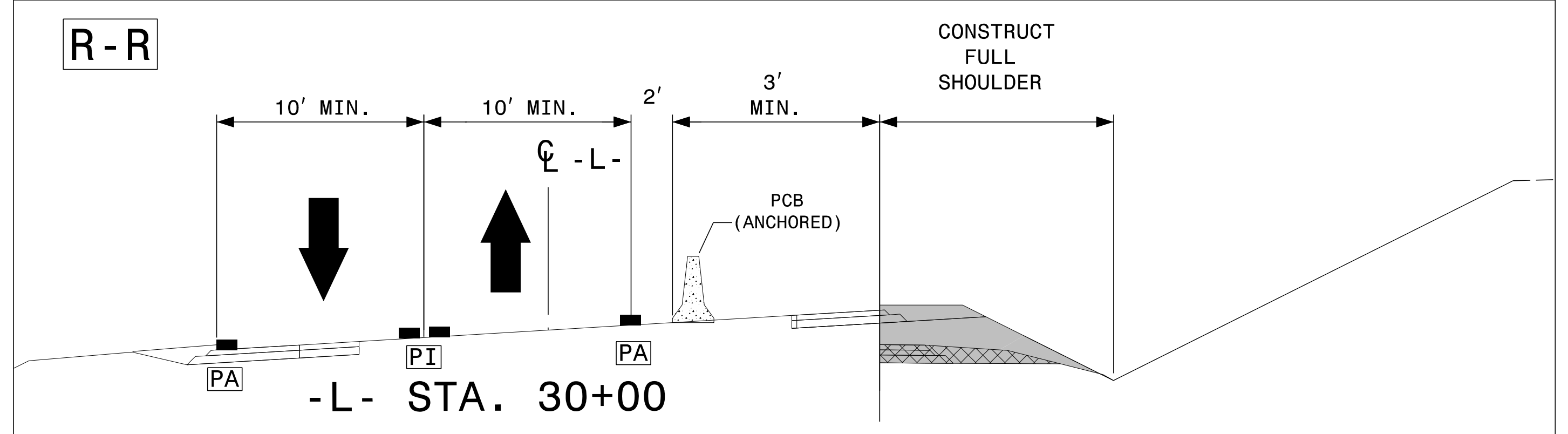
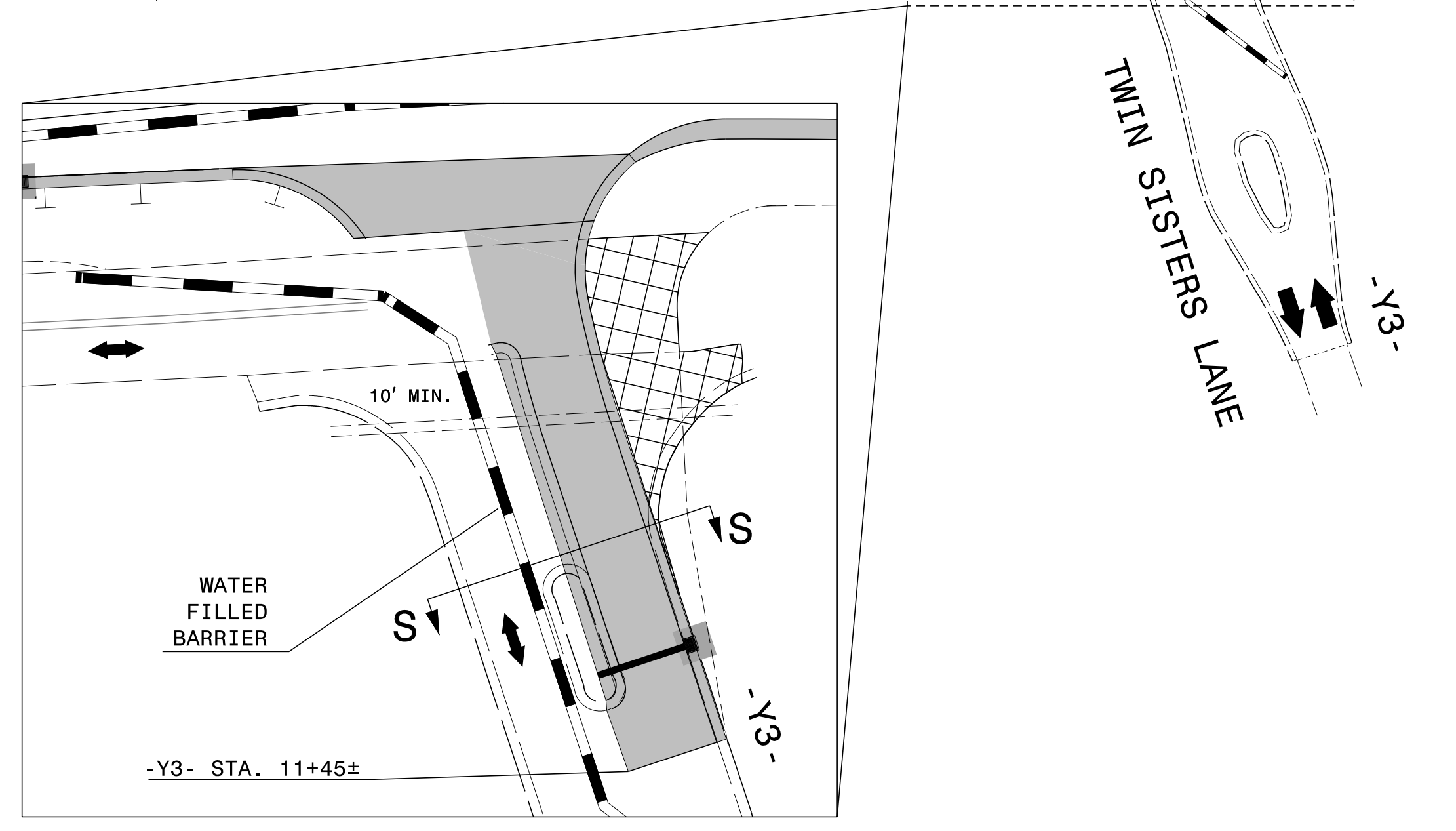
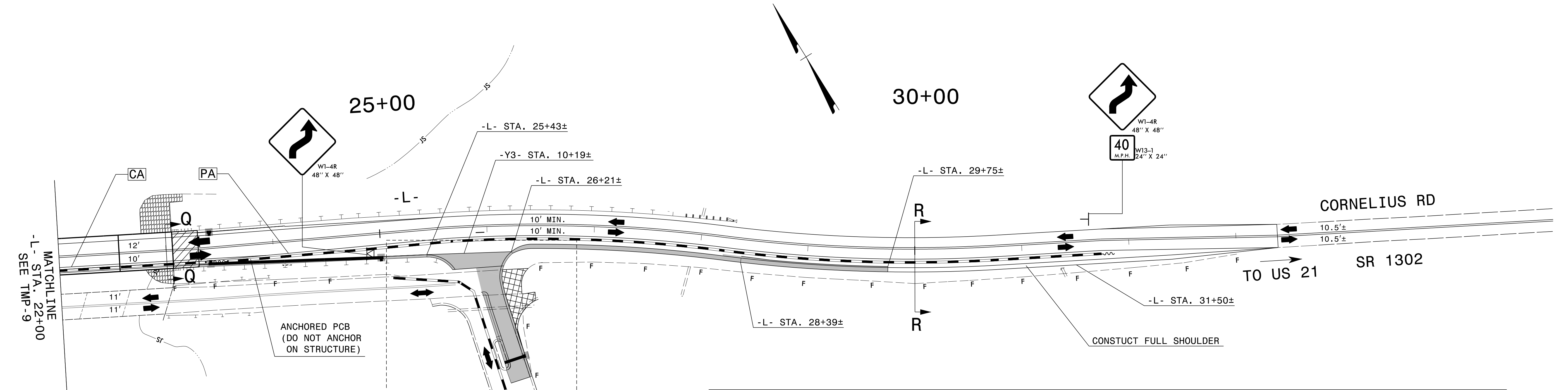

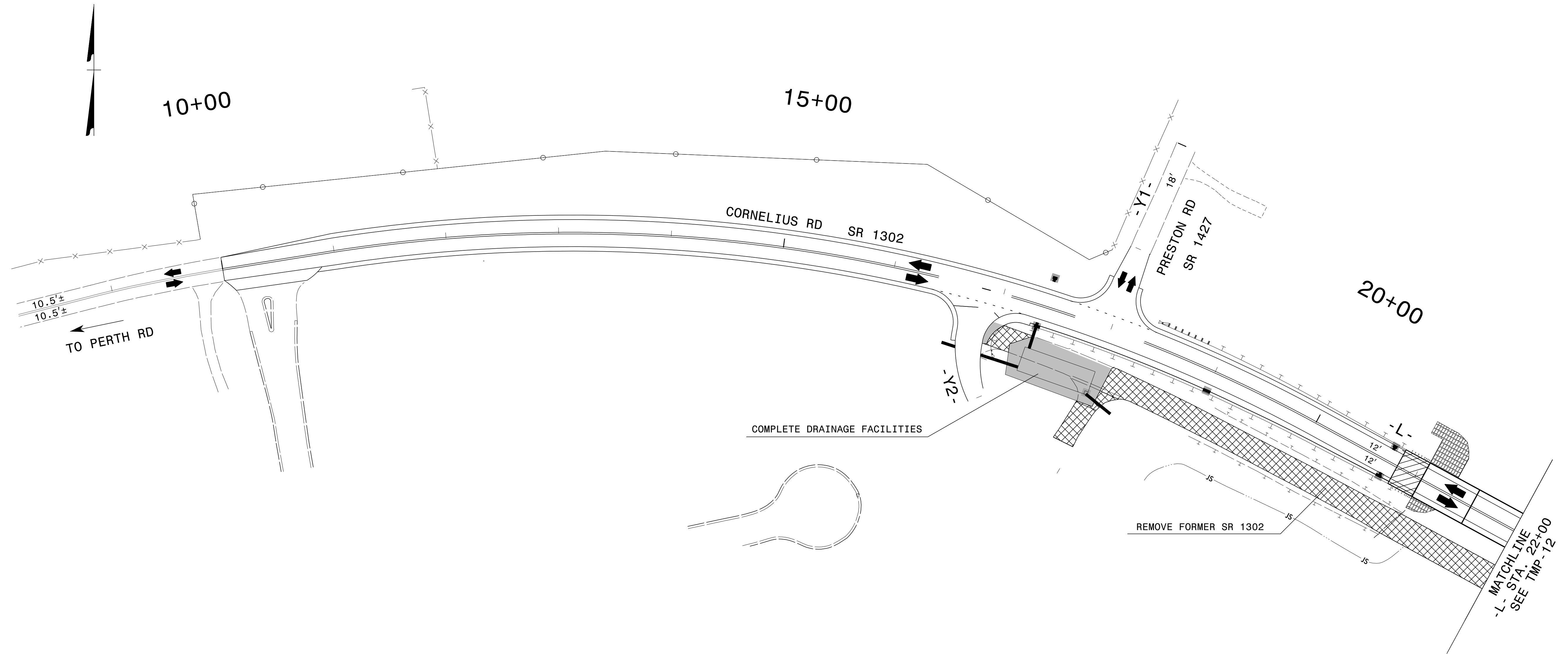

APPROVED: <i>J. W. Woolard, Jr.</i> DATE: 10/6/2015 		PHASE II DETAIL
--	--	----------------------------

10/5/2015
 P:\TipProjects\B-5142\TrafficControl\TCP\B-5142_TC_TMP_P3-2.dgn
 User: sfnasson



10/5/2015
 P:\TIP\Projects-B\B5142\TrafficControl\TCP\B-5142_TC_TMP_P4-1.dgn
 User:shanson

APPROVED: <i>J. W. Woolard, Jr.</i> <small>07918REBADS4427</small> DATE: 10/6/2015 		<p>PHASE III</p> <p>DETAIL</p>
---	---	--

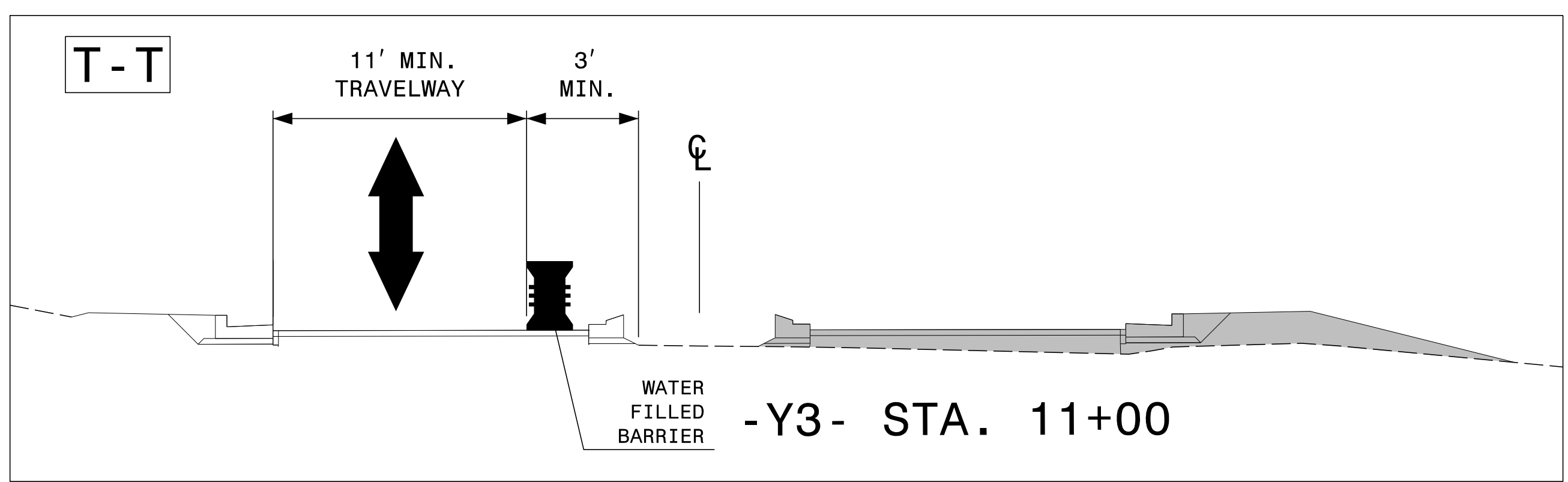
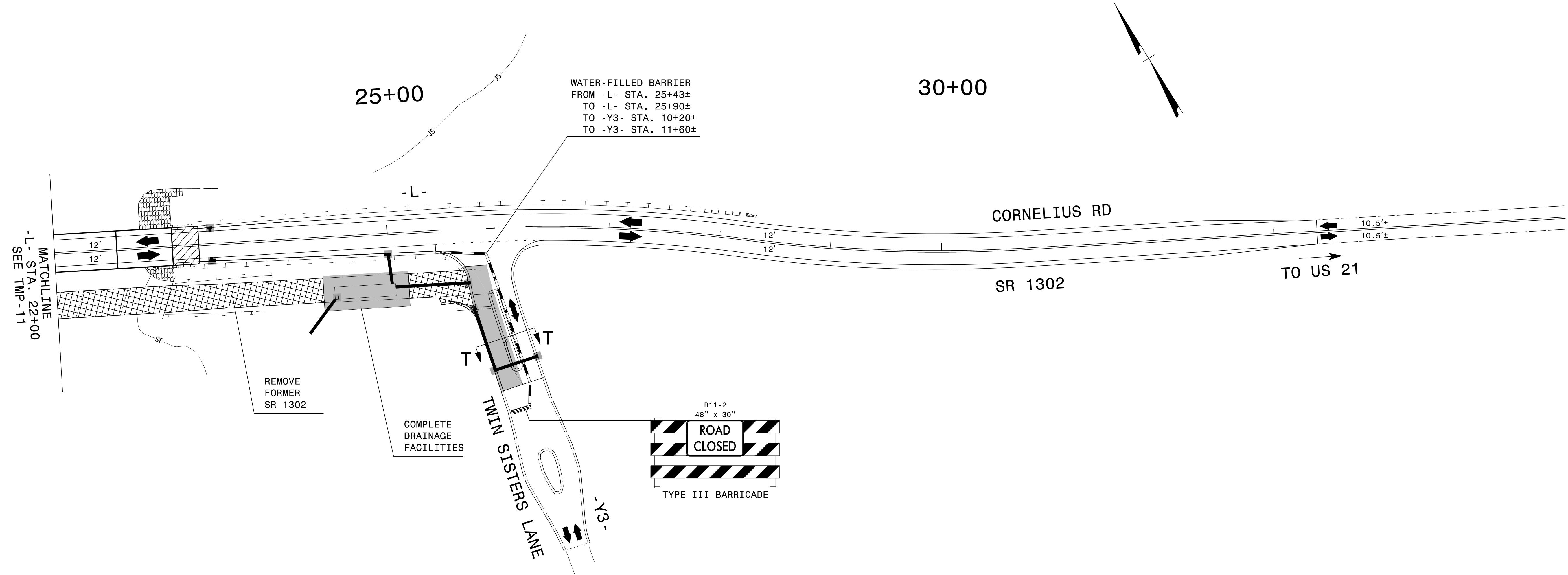

APPROVED: <i>J. W. Woolard, Jr.</i> DATE: 10/6/2015			PHASE III DETAIL
--	--	--	---------------------

10/5/2015
 P:\TipProjects-B\B5142\TrafficControl\TCP\B-5142_TC_TMP_P4-2.dgn
 User:shanson