

NOTES:

CONTRACTOR SHALL FIELD VERIFY THE EXISTING FORMED OPENING PRIOR TO OBTAINING JOINT MATERIAL.
 FOR FOAM JOINT SEALS, SEE SPECIAL PROVISIONS.
 FOR FOAM ELASTOMERIC CONCRETE, SEE SPECIAL PROVISIONS.
 RETAIN ALL EXISTING REINFORCING STEEL. CLEAN AND REPAIR AS NEEDED.
 THE WIDTH OF UNCOMPRESSED FOAM JOINT SEAL SHALL BE 2".
 IF THE EMBEDDED PORTION OF THE EXISTING PLASTIC WATERSTOP IS EXPOSED DURING REMOVAL OF UNSOUND CONCRETE OR IF UNSOUND CONCRETE IS REMOVED TO WITHIN 2" OF THE WATERSTOP, THE ENTIRE WATERSTOP SHALL BE REMOVED.

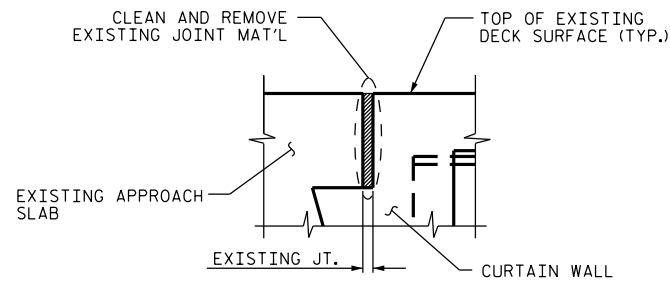

EXISTING JOINT

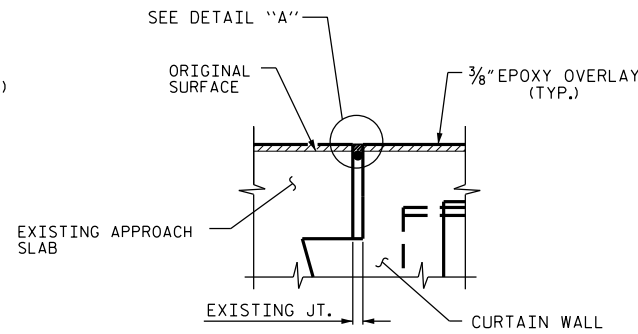

MINIMUM EXISTING JOINT DEMOLITION

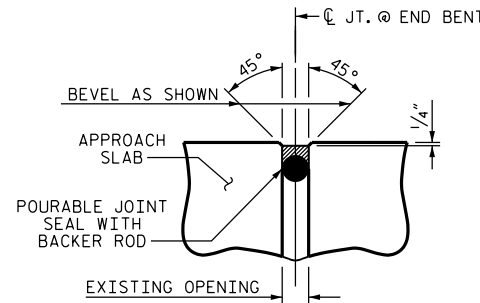

DETAIL "A"

**JOINT INSTALLATION SEQUENCE AT END BENTS
SECTION A-A**

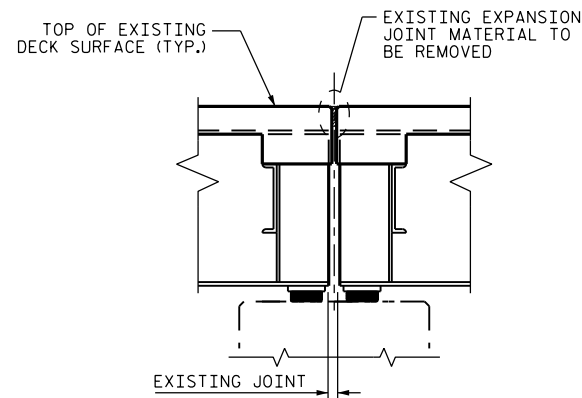

EXISTING JOINT

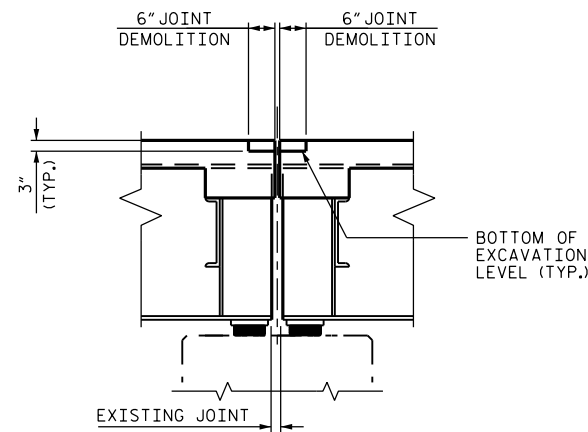

MINIMUM EXISTING JOINT DEMOLITION

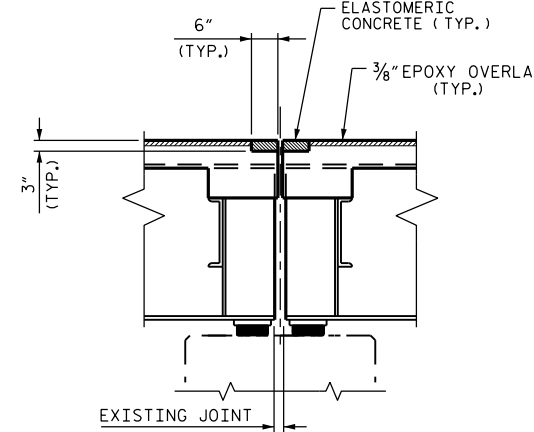

PROPOSED JOINT PRE-SAWED DIMENSIONS

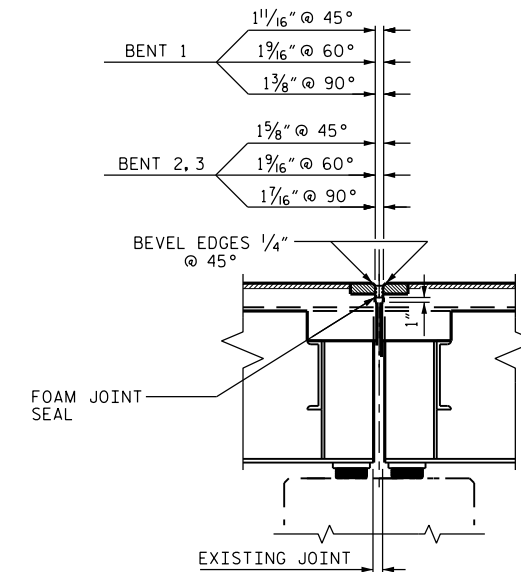

PROPOSED FOAM JOINT SEAL

**JOINT INSTALLATION SEQUENCE AT BENTS
SECTION B-B**

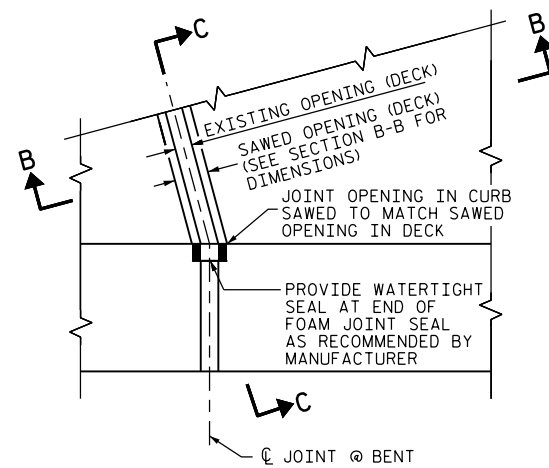

PLAN

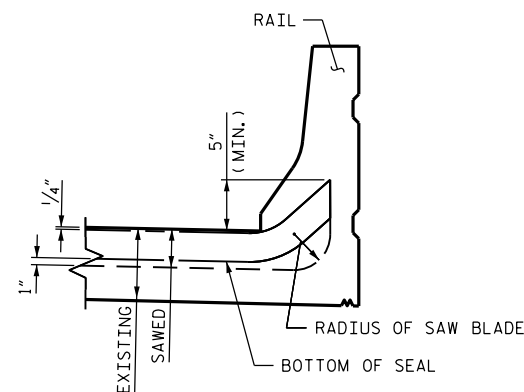

SECTION C-C

| ELASTOMERIC CONCRETE (CU. FT.)* | |
|---------------------------------|-------------|
| BENT 1 | 17.8 |
| BENT 2 | 18.0 |
| BENT 3 | 18.1 |
| TOTAL | 53.9 |

* BASED ON THE MINIMUM BLOCKOUT SHOWN

DocuSigned by:

W. Matthew Clarke

1EB20097EAAF437...



3/31/2016

PROJECT NO. I-5789
 GUILFORD COUNTY
 BRIDGE NO. 142

STATE OF NORTH CAROLINA
 DEPARTMENT OF TRANSPORTATION
 RALEIGH
**SUPERSTRUCTURE
 JOINT DETAILS**

DRAWN BY : S. I. SANDOR DATE : 01/2016
 CHECKED BY : W. M. CLARKE DATE : 02/2016

DOCUMENT NOT CONSIDERED
 FINAL UNLESS ALL
 SIGNATURES COMPLETED

| REVISIONS | | | | | | SHEET NO. |
|-----------|-----|-------|-----|-----|-------|--------------|
| NO. | BY: | DATE: | NO. | BY: | DATE: | TOTAL SHEETS |
| 1 | | | 3 | | | S-19 |
| 2 | | | 4 | | | 37 |