

**TYPE 4**

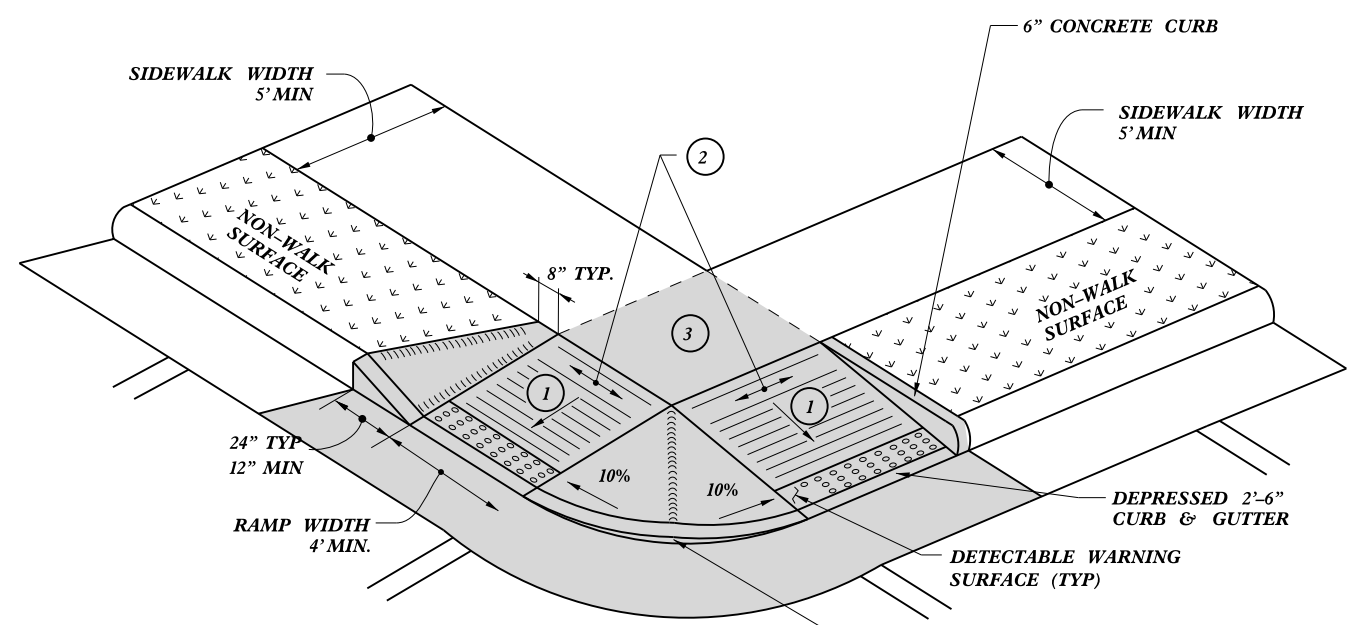

**TYPE 4A**

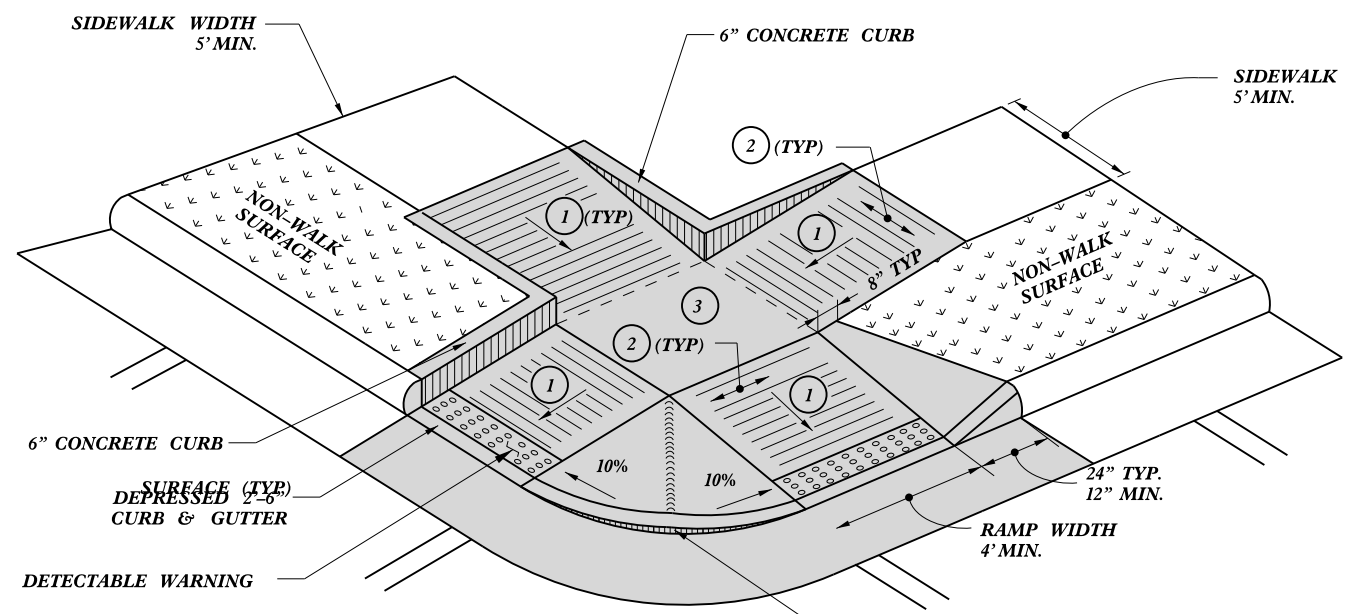

**TYPE 5**

PAY LIMITS FOR 2 CURB RAMPS

- 1 8.33% (12:1) MAX RAMP SLOPE
- 2 CROSS SLOPE: 2.00%
- 3 CURB RAMPS REQUIRE A (4'-0") MINIMUM LANDING WITH A MAXIMUM CROSS SLOPE AND LONGITUDINAL SLOPE OF 2.00% WHERE PEDESTRIANS PERFORM TURNING MANEUVERS. SLOPE TO DRAIN TO CURB.

DocuSigned by:  
 Joel S Howerton  
 449E8E25522144F...

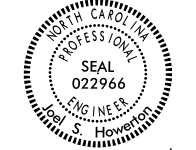

11/18/2015

DOCUMENT NOT CONSIDERED FINAL UNLESS ALL SIGNATURES COMPLETED

CONTRACT STANDARDS AND DEVELOPMENT UNIT  
 Office 919-707-6950 FAX 919-250-4119

**CURB RAMPS**  
 Shared Landing

ORIGINAL BY: J.S. HOWERTON DATE: 7/7/11  
 MODIFIED BY: DATE:  
 CHECKED BY: DATE:  
 FILE SPEC. :stds/2012CurbRamp/CurbRampDetails.dwg

REFER TO ROADWAY STANDARD DRAWING NUMBER 848.05 SHEET 3 OF 3 FOR ALL RAMP NOTES

5/14/99  
 \$\$\$\$\$\$SYTIME\$\$\$\$\$  
 \$\$\$\$\$\$CONUS\$\$\$\$\$  
 \$\$\$\$\$\$SERNAME\$\$\$\$\$  
 \$\$\$\$\$\$DU\$\$\$\$\$  
 \$\$\$\$\$\$\$\$\$\$\$