

NOTES

STIRRUPS IN CAP MAY BE SHIFTED AS NECESSARY TO CLEAR DOWELS.

THE CONCRETE IN THE SHADED AREA OF THE WING SHALL BE POURED AFTER THE CONCRETE PARAPET IS CAST IF SLIP FORMING IS USED.

FOR PILE SPLICE DETAILS, SEE SHEET 4 OF 4.

FOR WING DETAILS, SEE SHEET 3 OF 4.

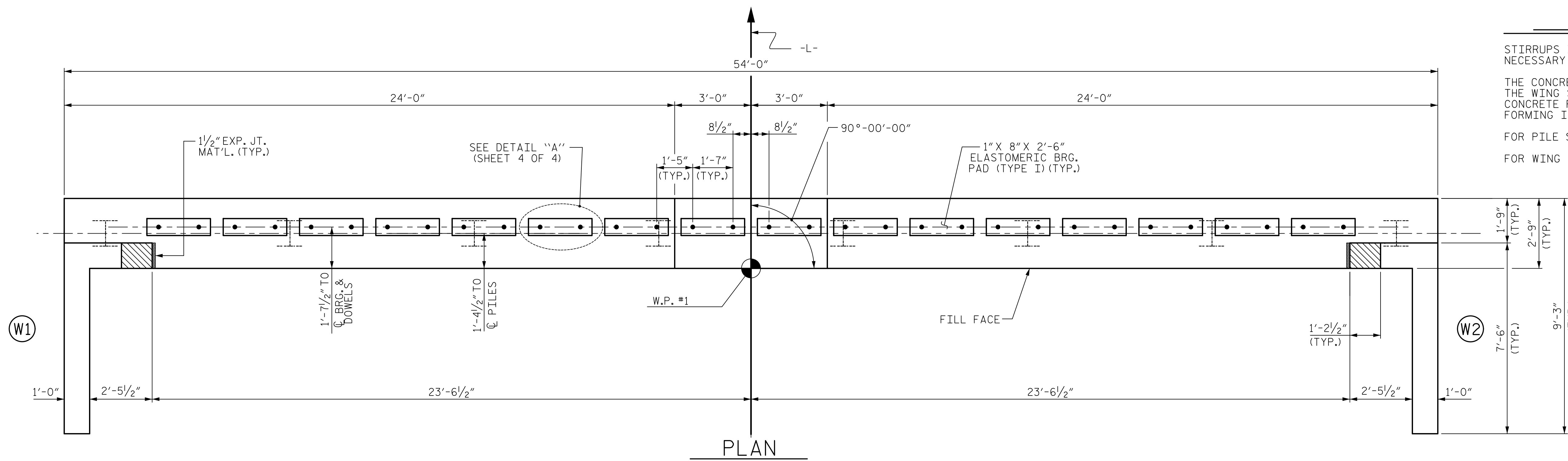

PLAN

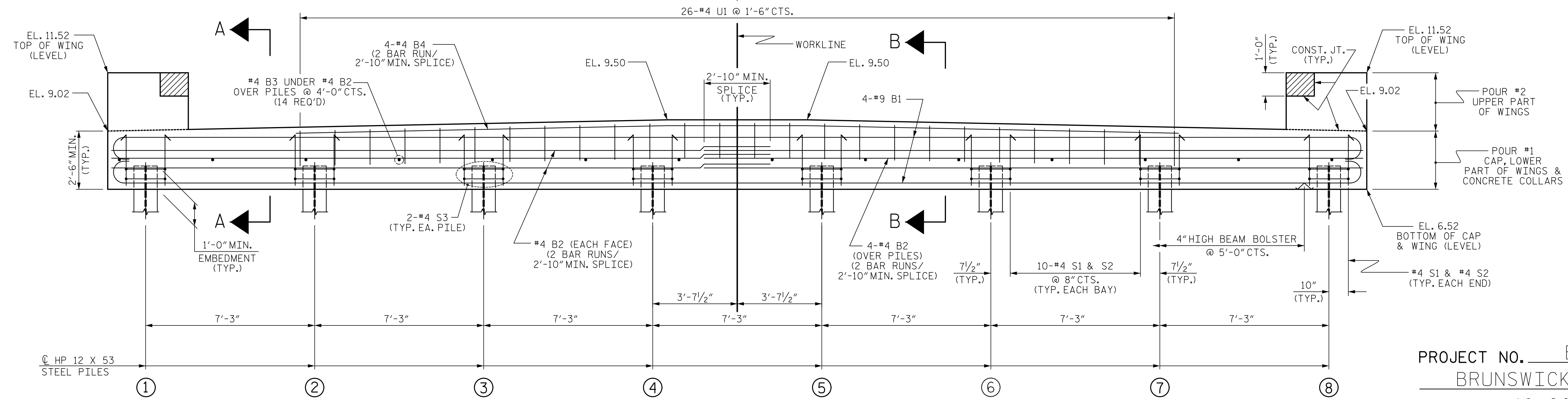

ELEVATION

WINGS NOT SHOWN FOR CLARITY.  
 FOR SECTION A-A, SEE SHEET 4 OF 4.  
 CONCRETE COLLARS FOR STEEL PILES NOT SHOWN IN PLAN AND ELEVATION VIEWS FOR CLARITY.  
 SEE "CORROSION PROTECTION FOR STEEL PILES DETAIL", SHEET 4 OF 4.

PROJECT NO. B-4440  
 BRUNSWICK COUNTY  
 STATION: 18+90.36 -L-

SHEET 1 OF 4

**Mead & Hunt**  
 127 W. Hargett Street  
 Suite 504  
 Raleigh, NC 27601  
 919-714-8670  
 meadhunt.com  
 NC License No. F-1235

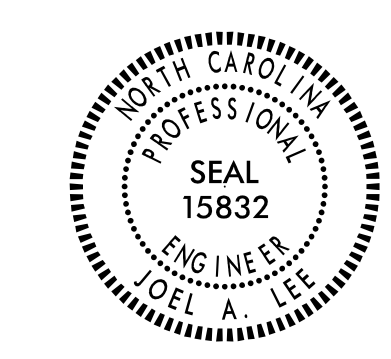

STATE OF NORTH CAROLINA  
 DEPARTMENT OF TRANSPORTATION  
 RALEIGH  
 SUBSTRUCTURE  
 END BENT No. 1

DRAWN BY : J.S. HOBSON DATE : 2/13/15  
 CHECKED BY : J.A. LEE DATE : 3/2/15  
 DESIGN ENGINEER OF RECORD : J.A. LEE DATE : 3/2/15

DOCUMENT NOT CONSIDERED  
 FINAL UNLESS ALL  
 SIGNATURES COMPLETED

REVISIONS						SHEET NO.
NO.	BY:	DATE:	NO.	BY:	DATE:	S-14
1			3			TOTAL SHEETS
2			4			22