

-Y1-		
PI Sta 16+60.81	PI Sta 20+86.13	PI Sta 22+90.78
$\Delta = 10^{\circ} 02' 34.3" (LT)$	$\Delta = 77^{\circ} 55' 39.9" (LT)$	$\Delta = 20^{\circ} 33' 03.6" (LT)$
D = 5' 43' 46.5"	D = 54' 34' 02.7"	D = 19' 05' 54.9"
L = 175.28'	L = 142.81'	L = 107.60'
T = 87.87'	T = 84.92'	T = 54.39'
R = 1,000.00'	R = 105.00'	R = 300.00'
SE = EXIST	SE = EXIST	SE = EXIST

-L-		-D-	
PI Sta 33+90.26	PI Sta 24+23.74		
$\Delta = 46^{\circ} 49' 43.7" (LT)$	$\Delta = 08^{\circ} 05' 17.3" (LT)$		
D = 3' 34' 51.6"	D = 3' 49' 11.0"		
L = 1,307.71'	L = 211.75'		
T = 692.86'	T = 106.05'		
R = 1,600.00'	R = 1,500.00'		
SE = .04	SE = .02		
RUNOFF=48.4'			
PT Sta.40+05.11			
N 64°16'01.0" E			

RETAINING WALL #1 : BEGINS AT STA.-L- 38+40 RT
ENDS AT STA.-L- 40+30 RT

RETAINING WALL #2 : BEGINS AT STA.-L- 39+30 LT
ENDS AT STA.-L- 42+85 LT

RETAINING WALL #5 : BEGINS AT STA.-L- 40+70 RT
ENDS AT STA.-L- 41+95 RT

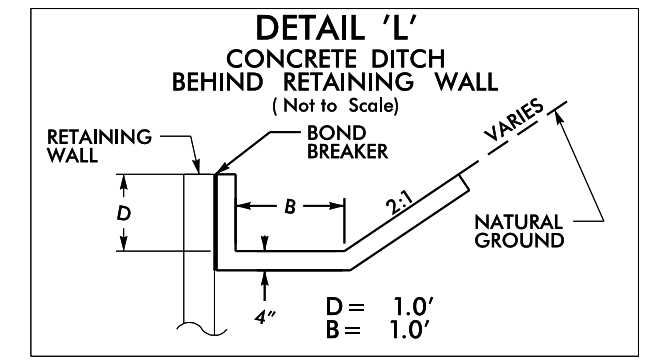

FROM STA.38+50 TO STA.40+20 -L- RT.
FROM STA.39+30 TO STA.42+85 -L- LT.
FROM STA.40+70 TO STA.41+95 -L- RT.

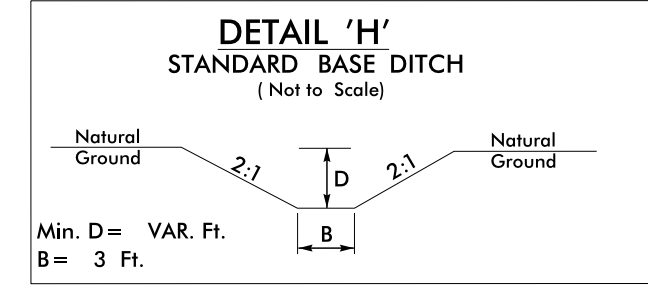

Min. D = VAR. FT.
B = 3 FT.

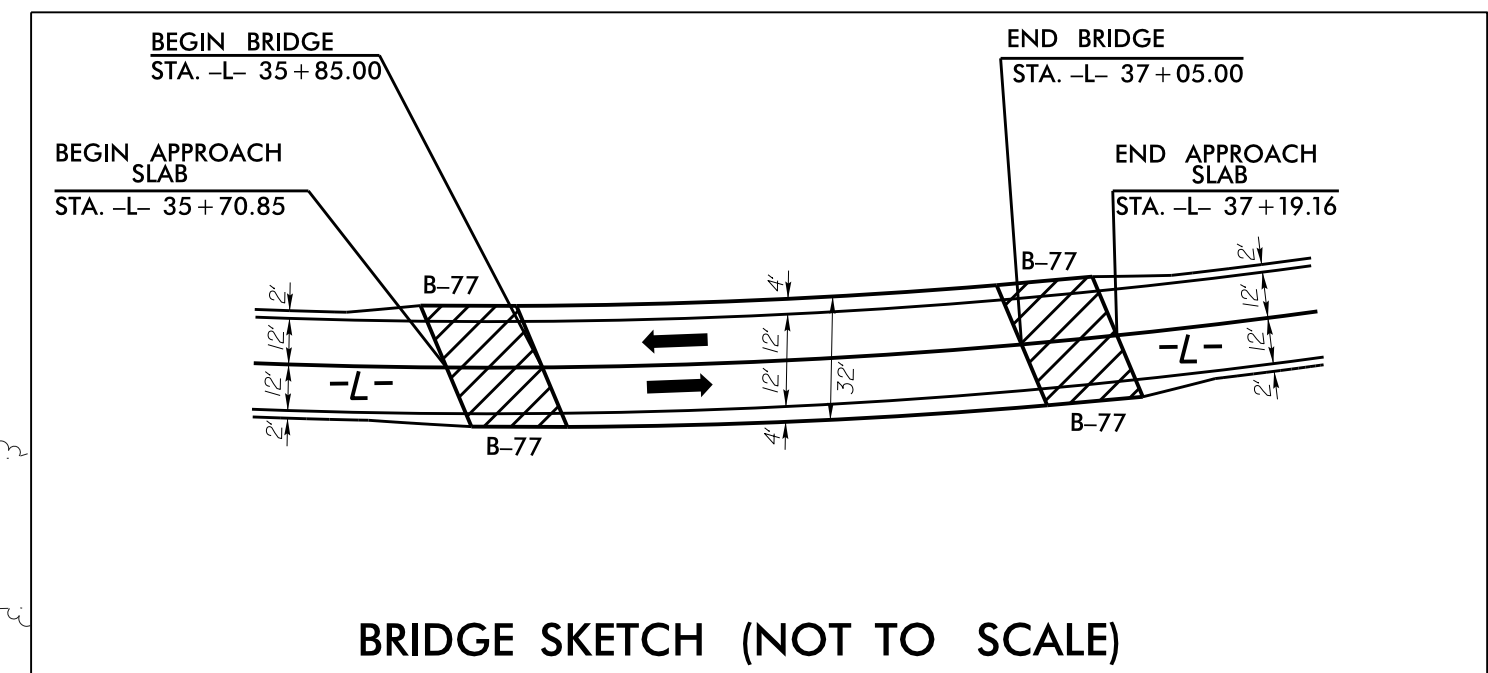

BRIDGE SKETCH (NOT TO SCALE)

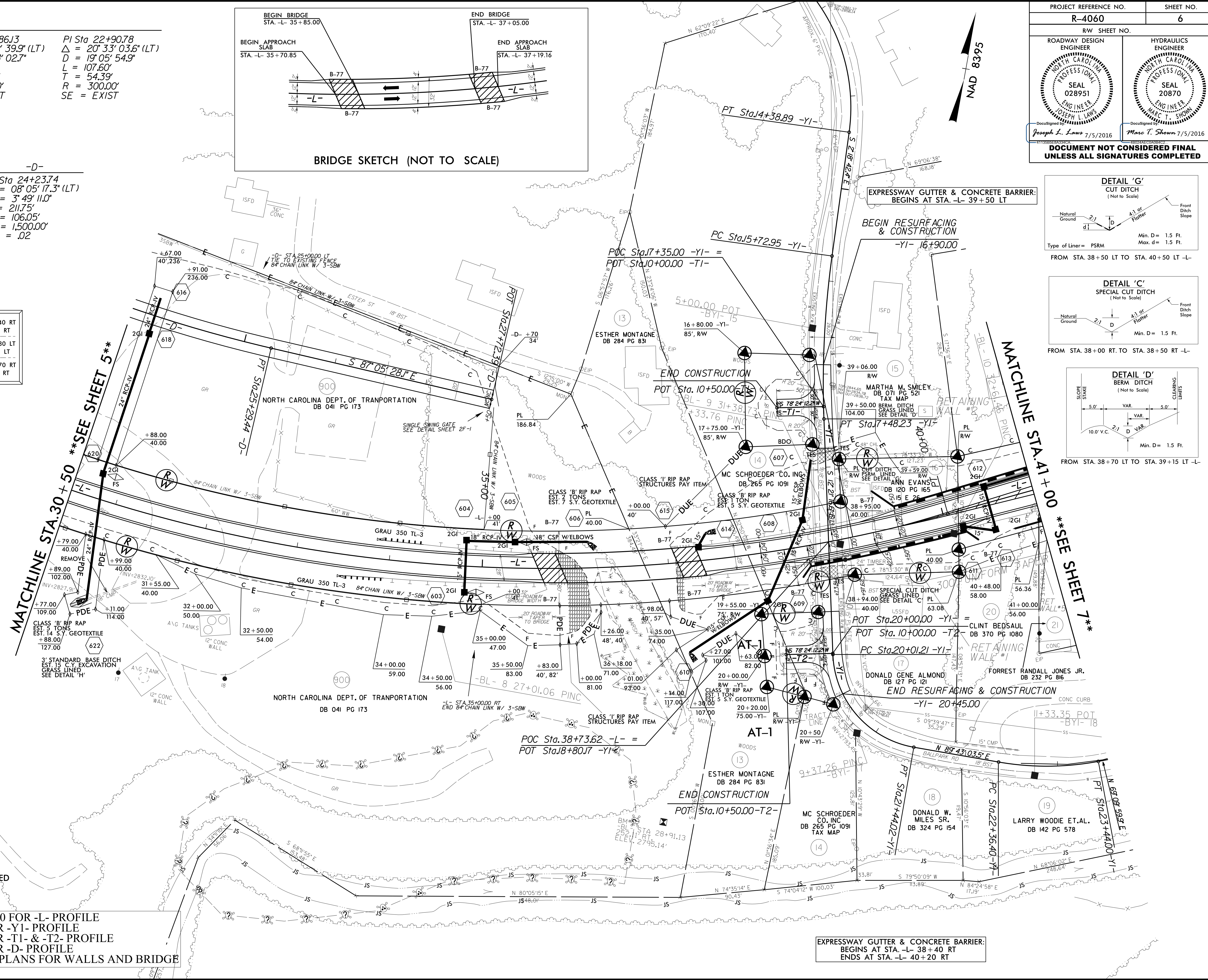

NOTE : (1) SEE SHEETS 9 & 10 FOR -L- PROFILE
(2) SEE SHEET 12 FOR -Y1- PROFILE
(3) SEE SHEET 13 FOR -T1- & -T2- PROFILE
(4) SEE SHEET 15 FOR -D- PROFILE
(5) SEE STRUCTURE PLANS FOR WALLS AND BRIDGE

EXPRESSWAY GUTTER & CONCRETE BARRIER:
BEGINS AT STA.-L- 38+40 RT
ENDS AT STA.-L- 40+20 RT

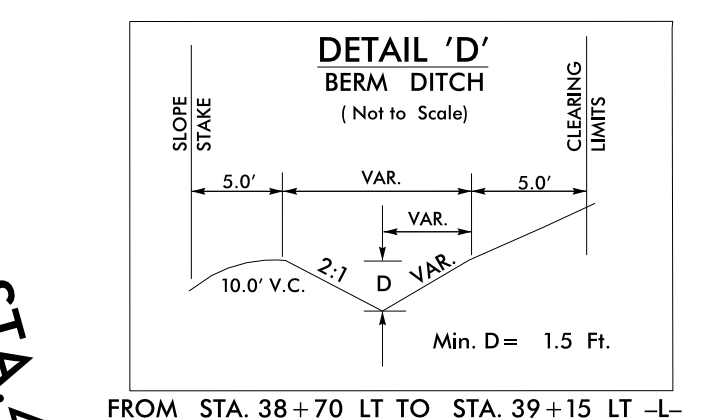
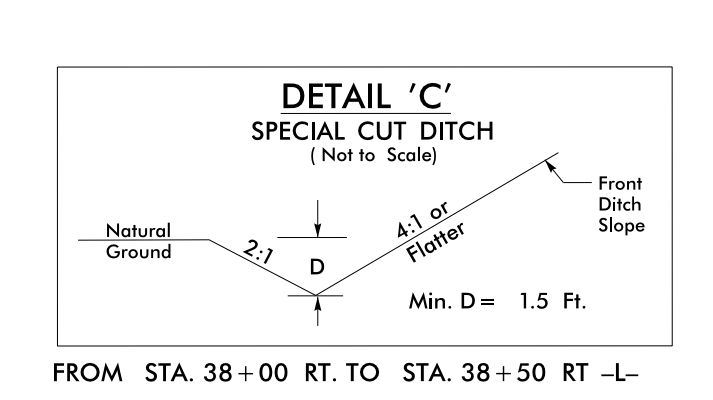
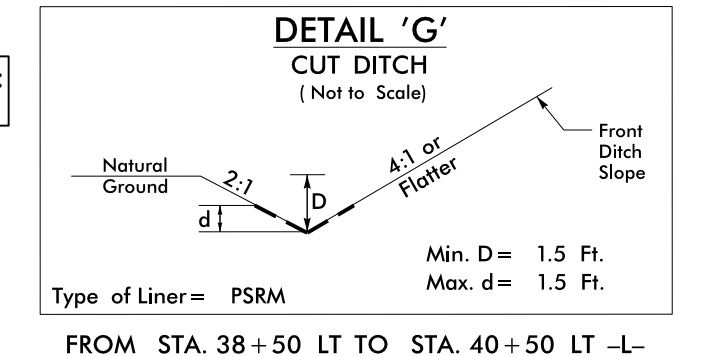

8/17/199
23 JUN 2016 07:41
9:58:51 USER:MAJ05