

**This electronic collection of documents is provided
for the convenience of the user
and is Not a Certified Document –**

**The documents contained herein were originally issued
and sealed by the individuals whose names and license
numbers appear on each page, on the dates appearing
with their signature on that page.**

**This file or an individual page
shall not be considered a certified document.**

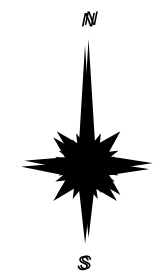
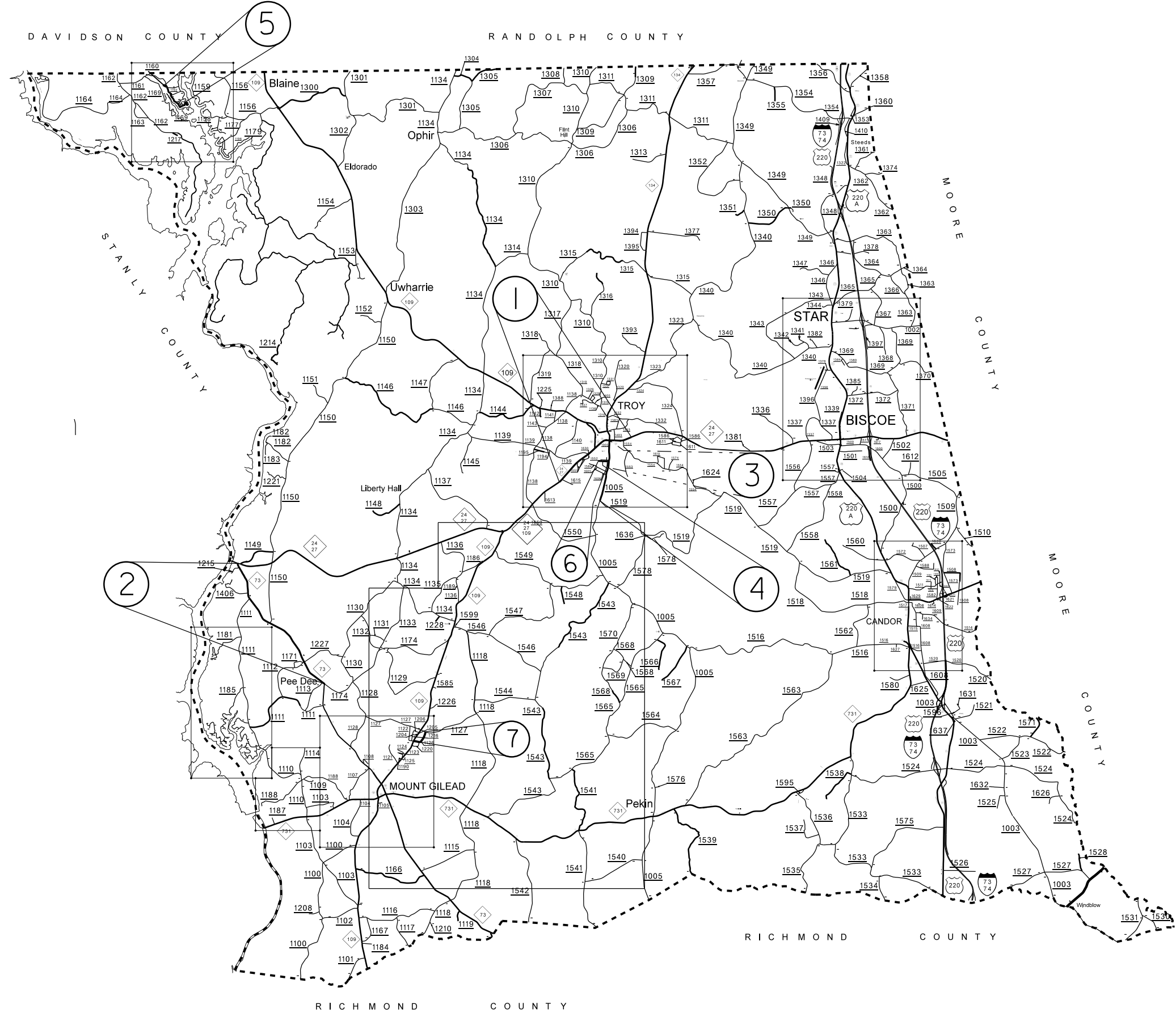

MONTGOMERY COUNTY
RESURFACING MAP

040397
 I:\MAY_2016\4404\2017_CPT\08\02\10621\10761\20761\Montgomery_Randolph_July_2016_Submittal\Montgomery_Randolph_July_2016_Overview_Map.dgn
 17-MAY-2016 14:04
 User: jason.patterson

MAPS #5

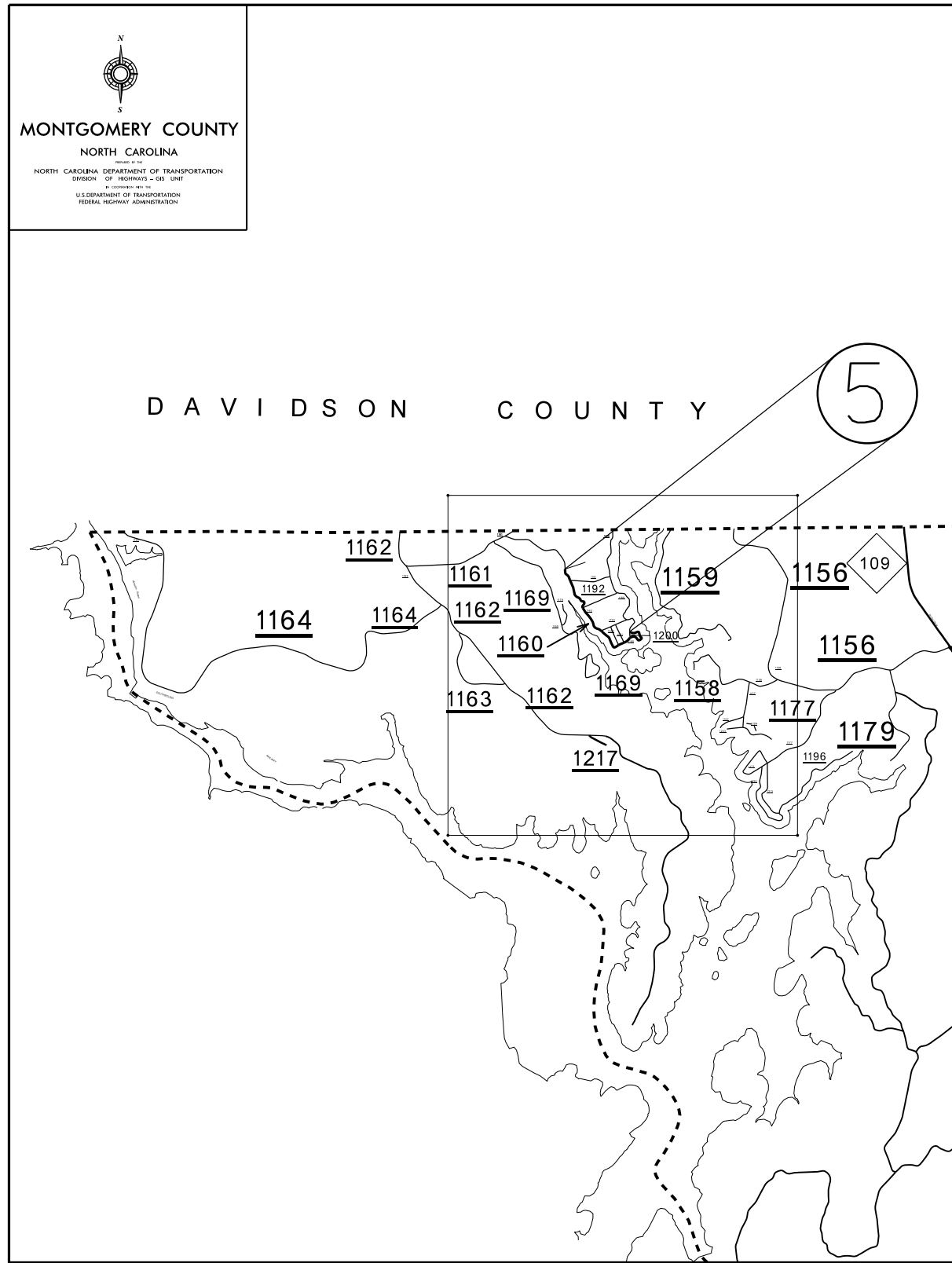

MAP #7

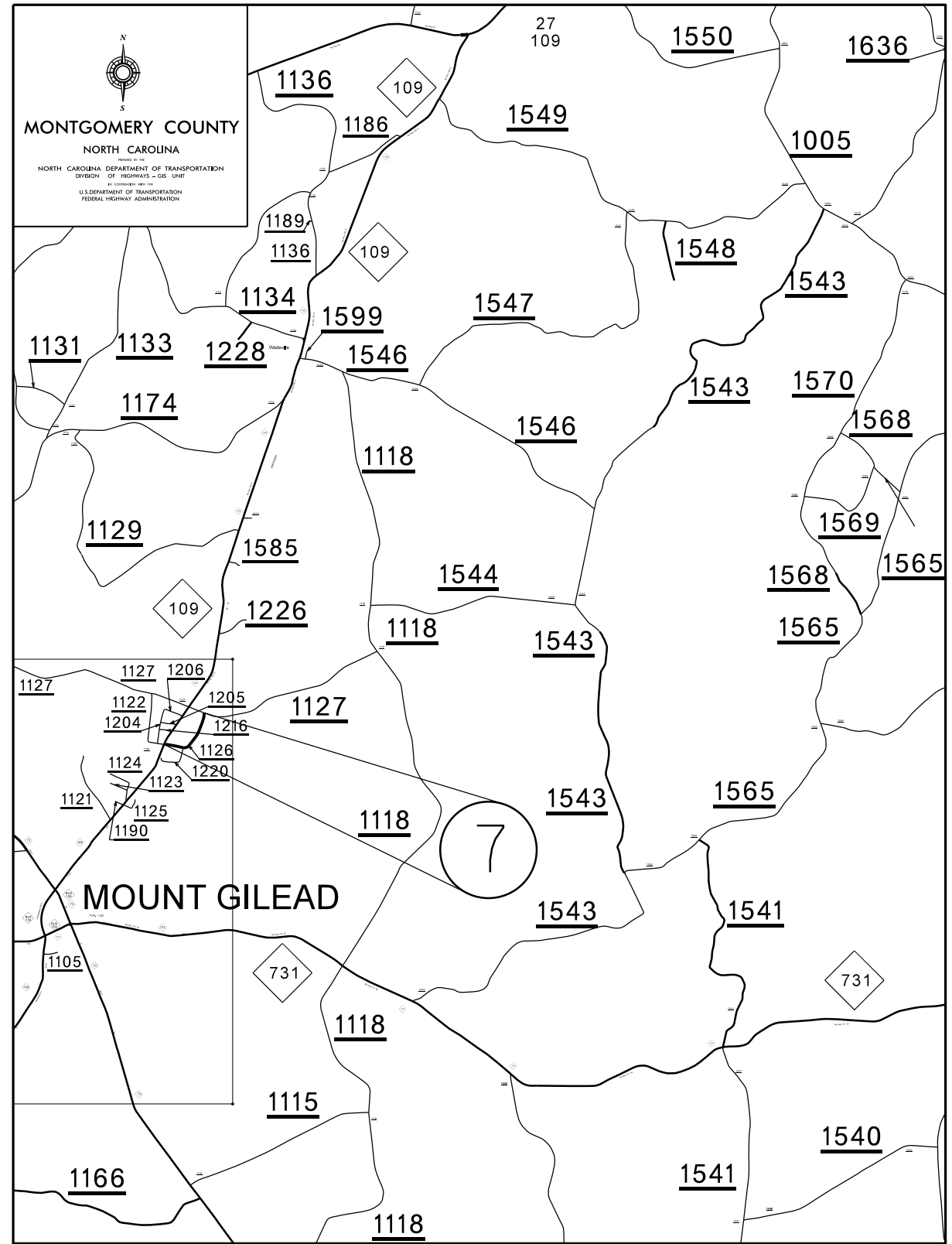

040397

C:\Users\p111\OneDrive\Documents\Projects\2016\17-MAY-2016-1431-17-May-2016-1431\Randolph-July-2016-Submittal\Montgomery-July-2016-VICINITY_MAPS.dgn

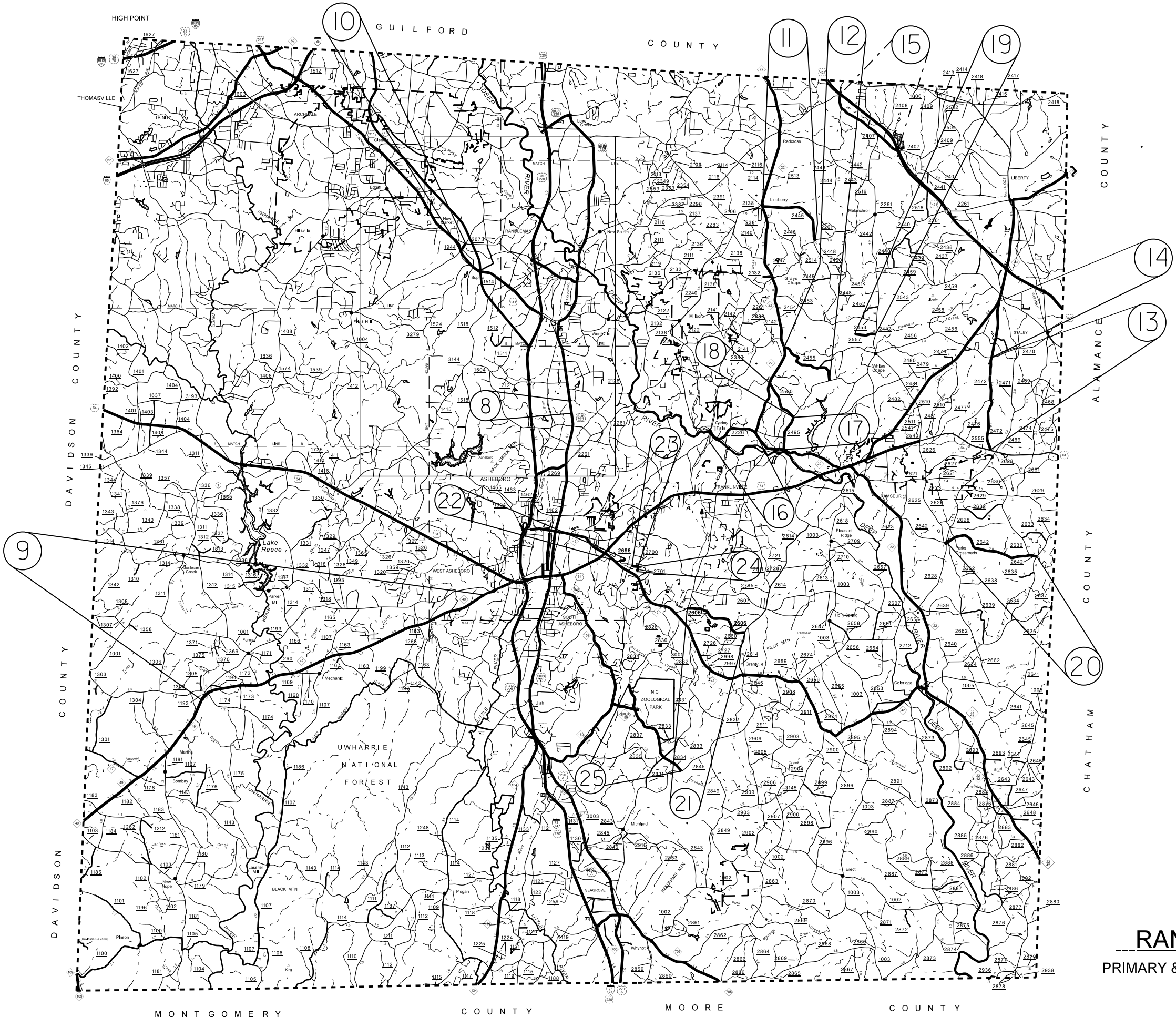

RANDOLPH COUNTY
PRIMARY & SECONDARY RESURFACING MAP

17-MAY-2016 4:04 PM
C:\Users\mccormack\OneDrive\Documents\Randolph_County\GIS\Map_Series\Map_Series.dwg
17-MAY-2016 4:04 PM
C:\Users\mccormack\OneDrive\Documents\Randolph_County\GIS\Map_Series\Map_Series.dwg

MAPS #8 & #10

MAP #15

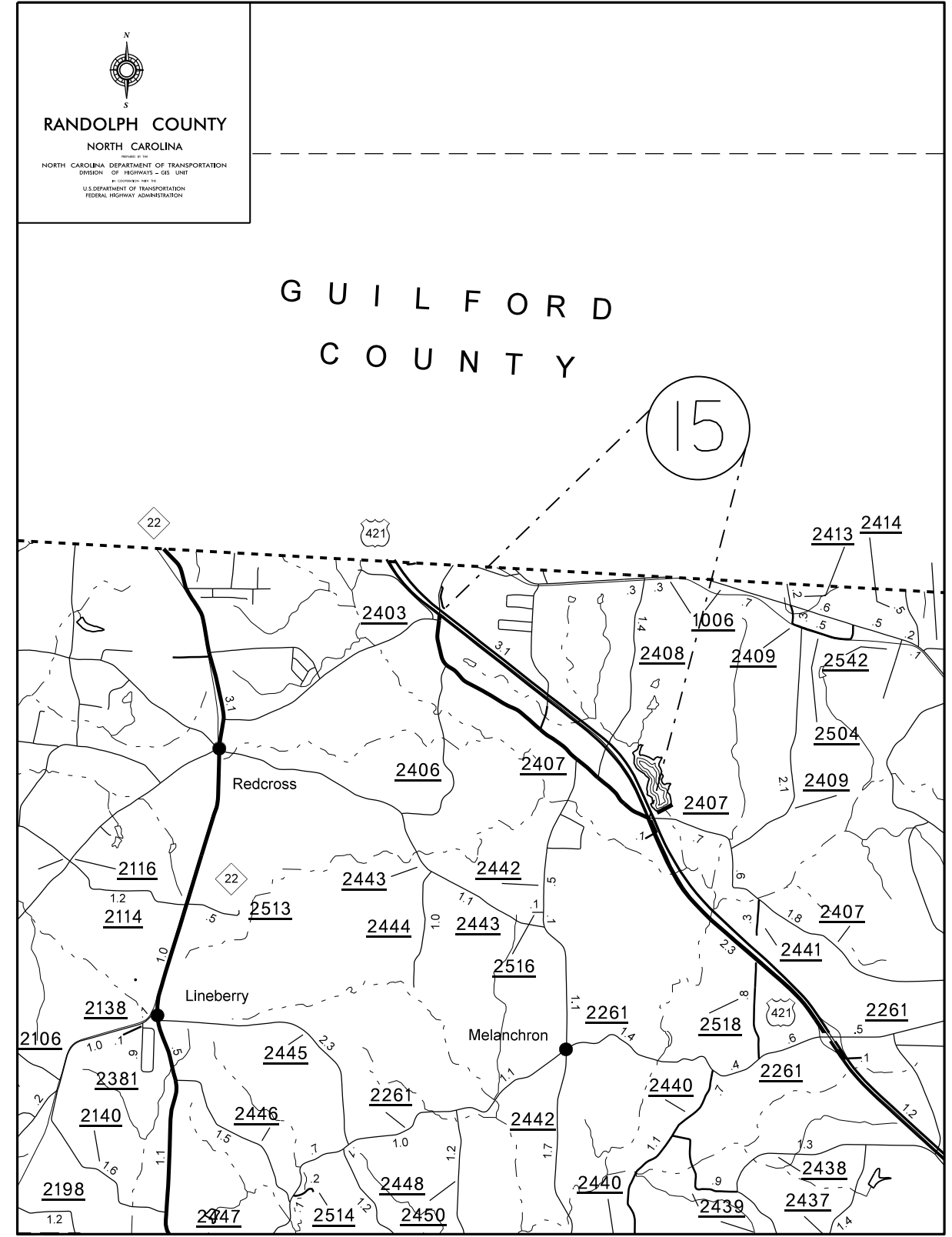
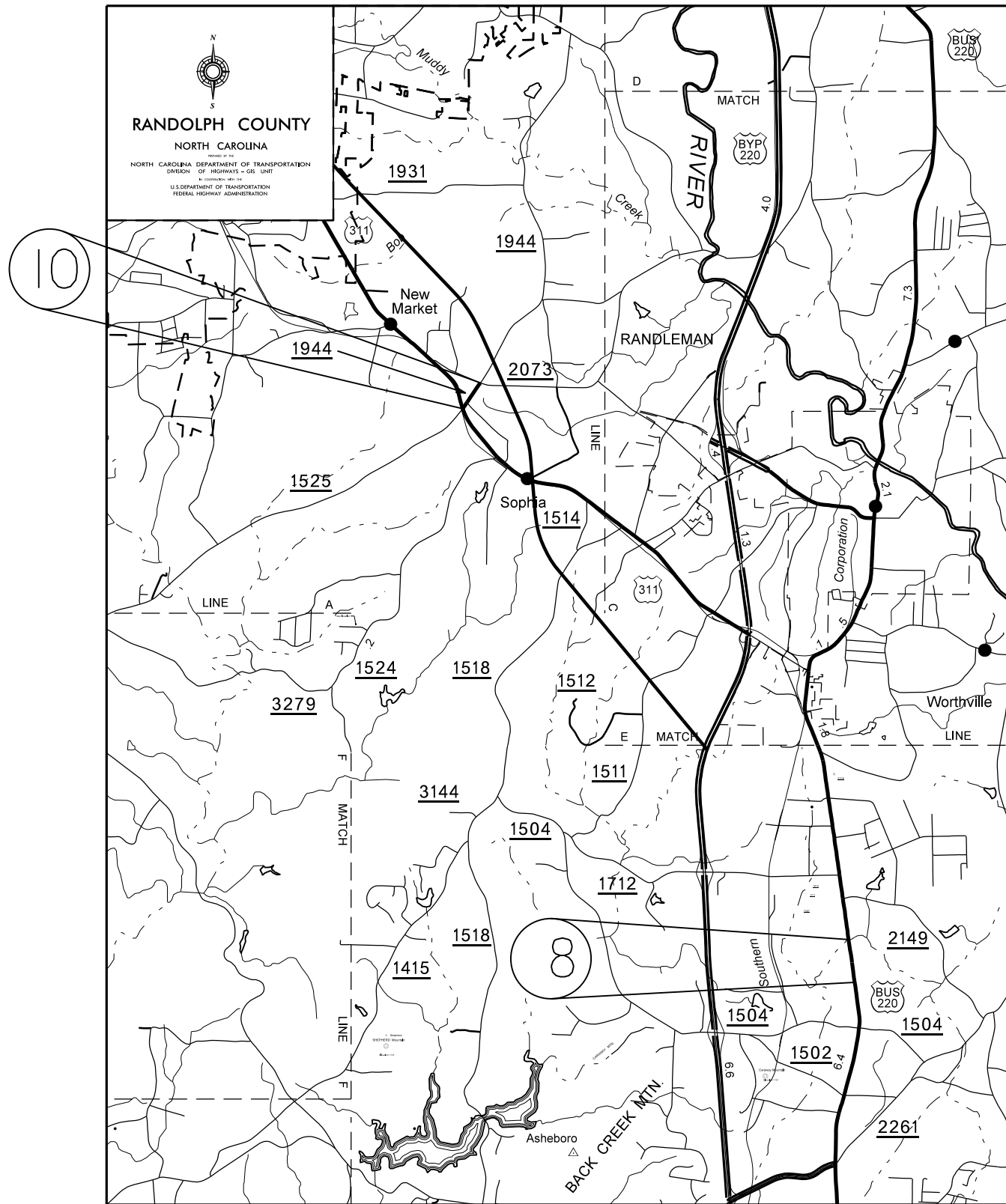

040397

17-MAY-2016 14:54
 mapgy-randolph-july-2016-Submittal-Randolph-july-2016-Vis-Maps.dgn

MAPS #13 - #14 & #20

MAP #9

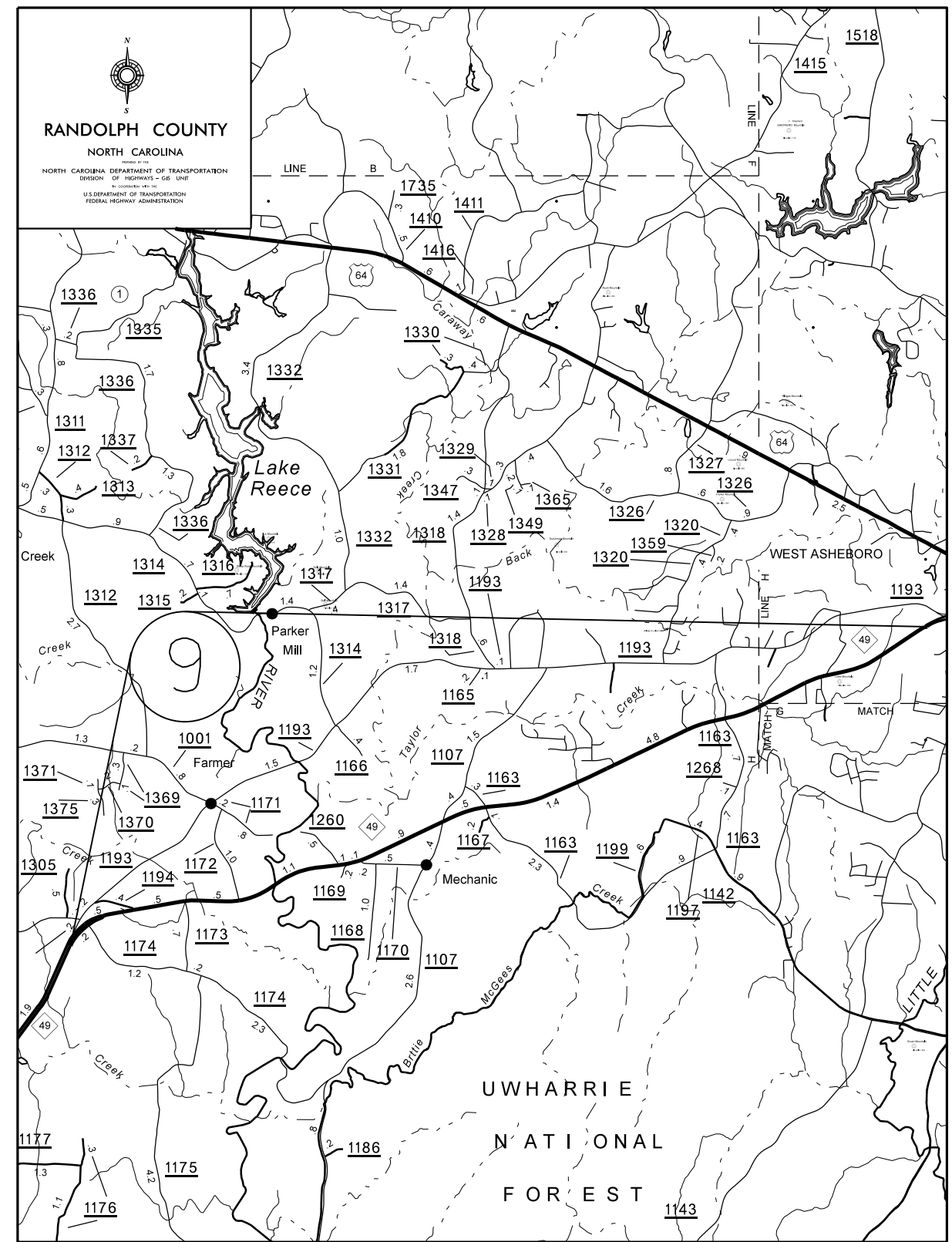
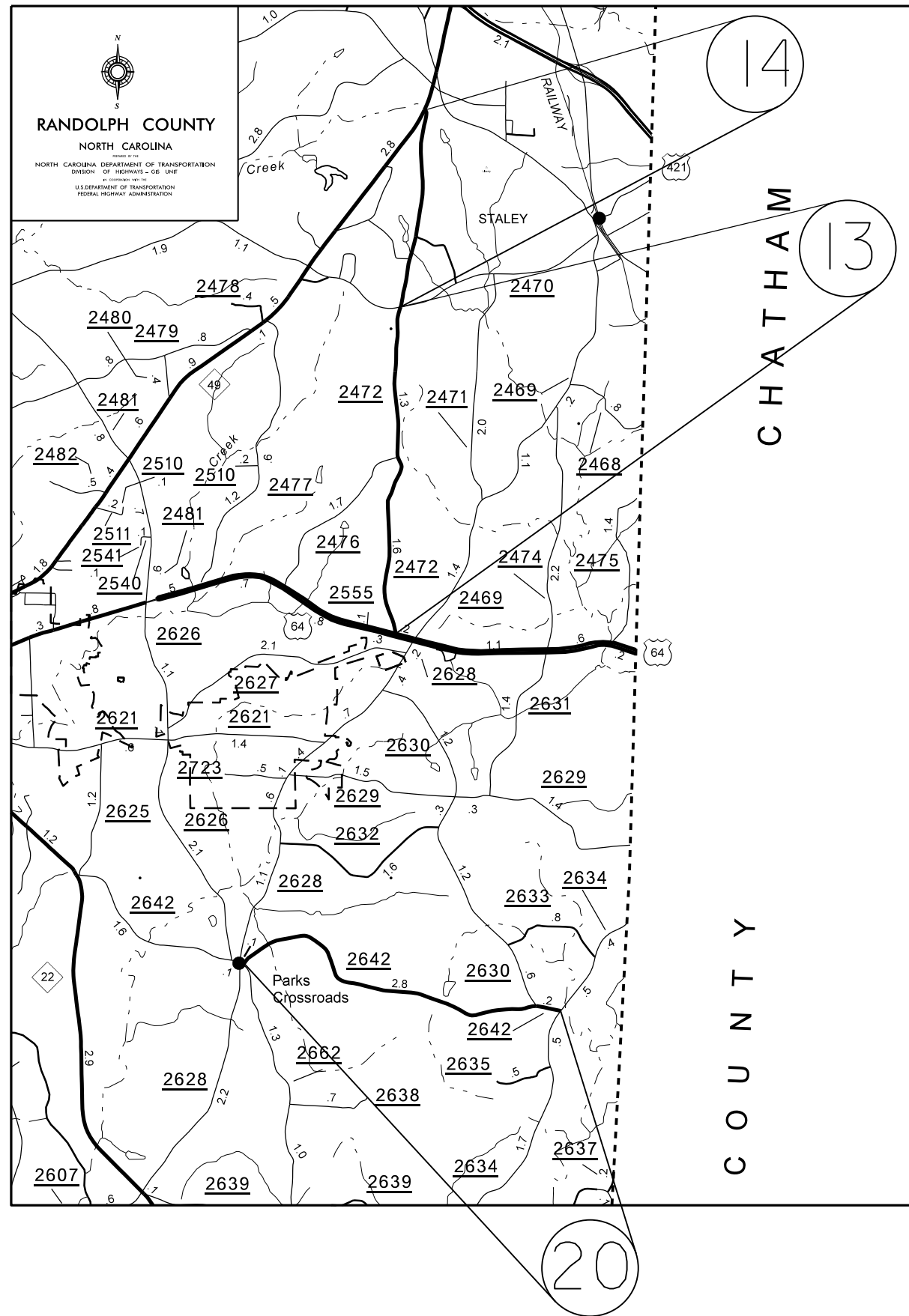

MAPS #22 - #26

(INSET)

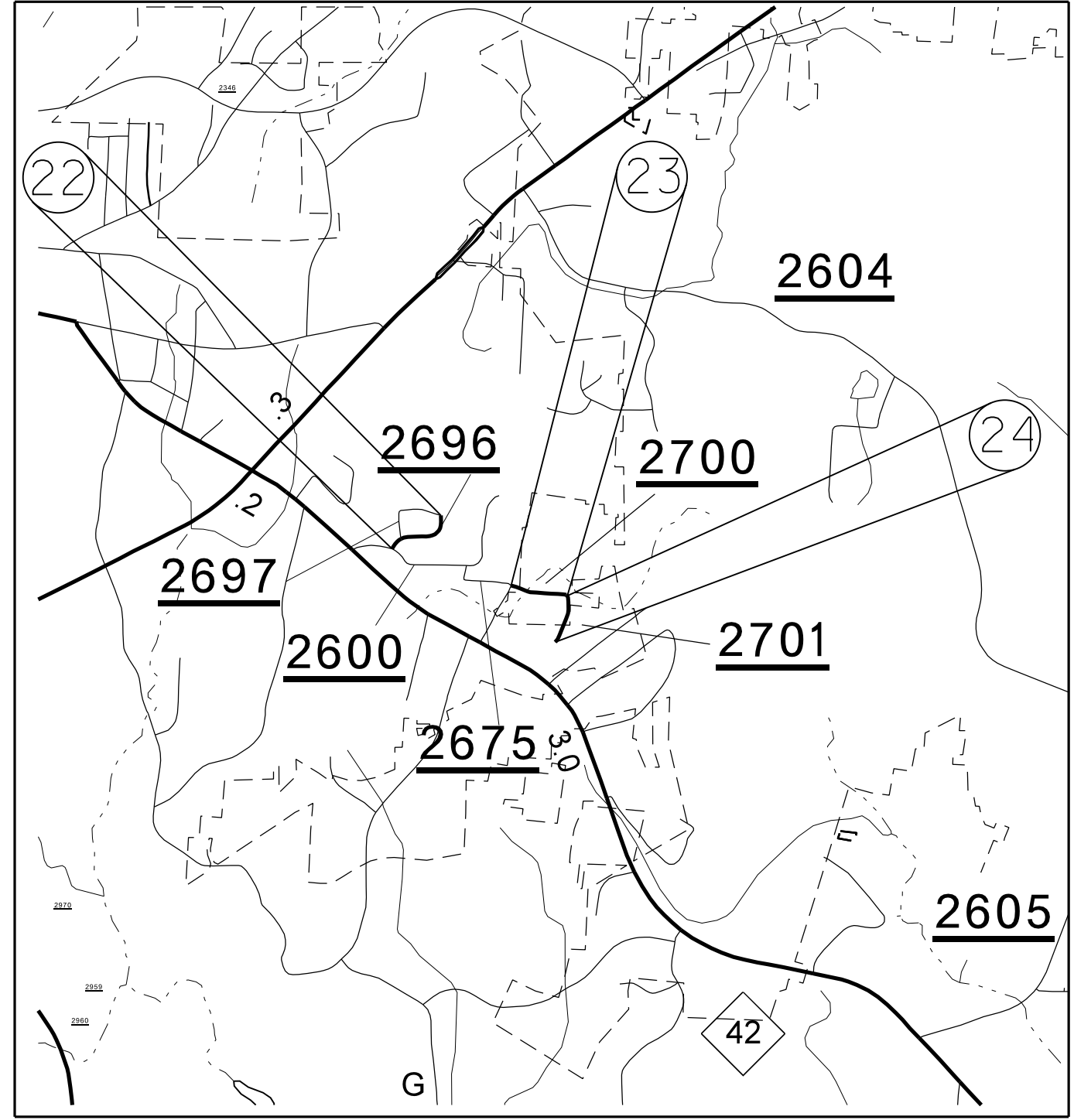
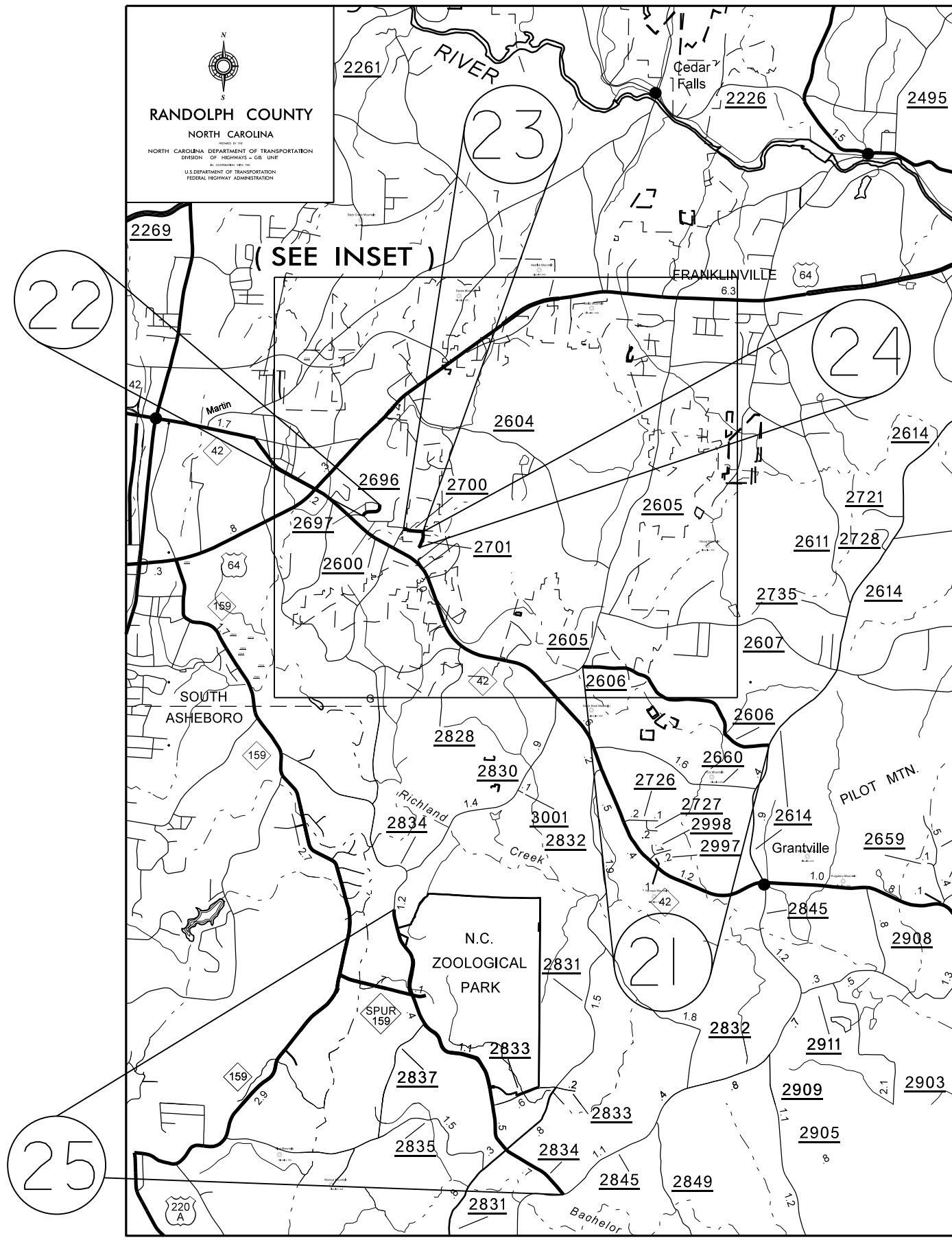

MONTGOMERY COUNTY TYPICALS

WBS ELEMENT	SHEET NO.
2017CPT.08.02.10621	9
2017CPT.08.02.20621	
2017CPT.08.02.10761	
2017CPT.08.02.20761	

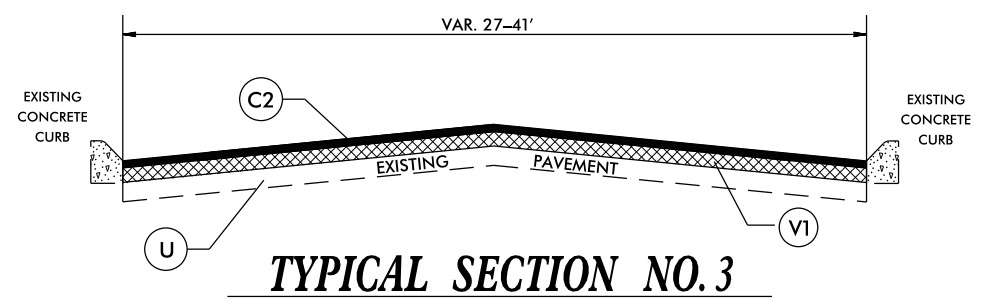
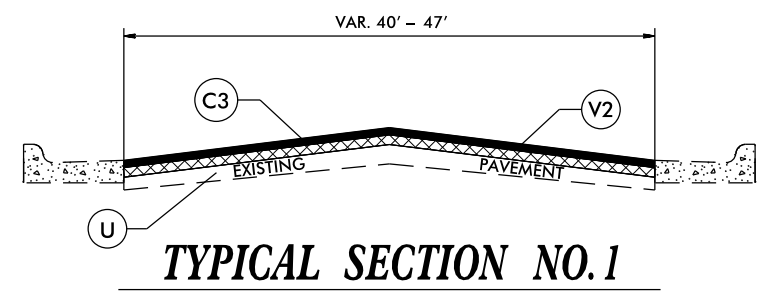

NOTE: MONTGOMERY COUNTY MAINTENANCE WILL BE RESPONSIBLE FOR SHOULDER RECONSTRUCTION AND PATCHING OF EXISTING PAVEMENT

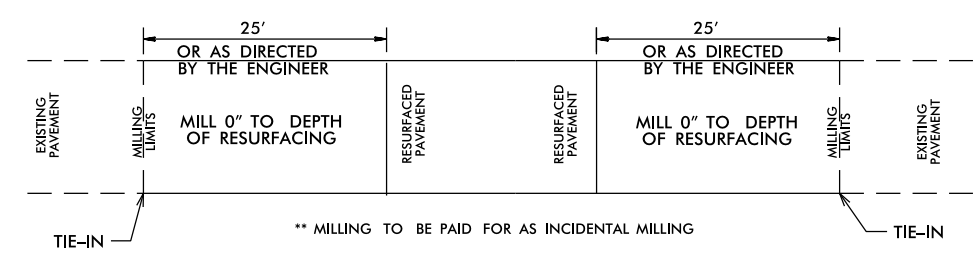
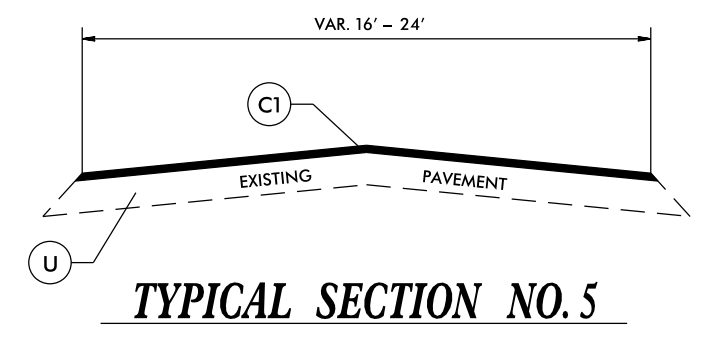
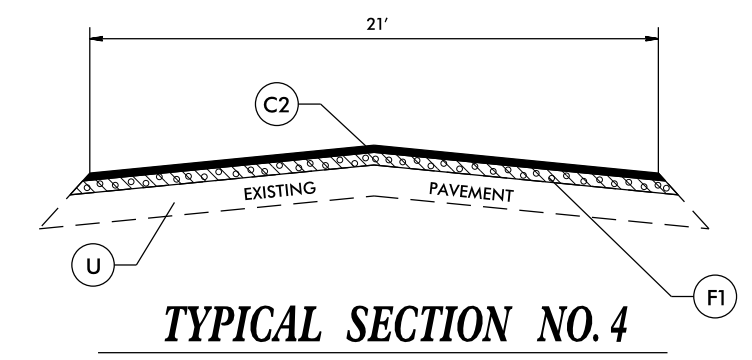
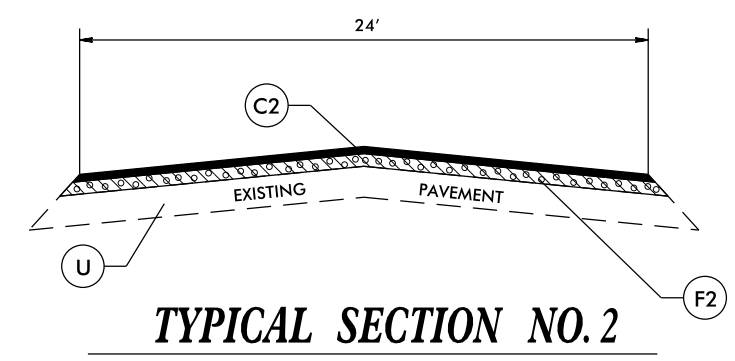

PAVEMENT TIE-IN DETAIL

PAVEMENT SCHEDULE	
C1	PROP. APPROX. 1.25" ASPHALT CONCRETE SURFACE COURSE, TYPE SF9.5A, AT AN AVERAGE RATE OF 137.5 LBS. PER SQ. YD.
C2	PROP. APPROX. 1.5" ASPHALT CONCRETE SURFACE COURSE, TYPE S9.5B, AT AN AVERAGE RATE OF 168 LBS. PER SQ. YD.
C3	PROP. APPROX. 2.0" ASPHALT CONCRETE SURFACE COURSE, TYPE S9.5B, AT AN AVERAGE RATE OF 224 LBS. PER SQ. YD.
F1	ASPHALT SURFACE TREATMENT, MAT COAT WITH #67 STONE
F2	ASPHALT SURFACE TREATMENT-SINGLE SEAL
V1	MILLING 1.5" IN DEPTH
V2	MILLING 2"
U	EXISTING PAVEMENT.

RANDOLPH COUNTY TYPICALS

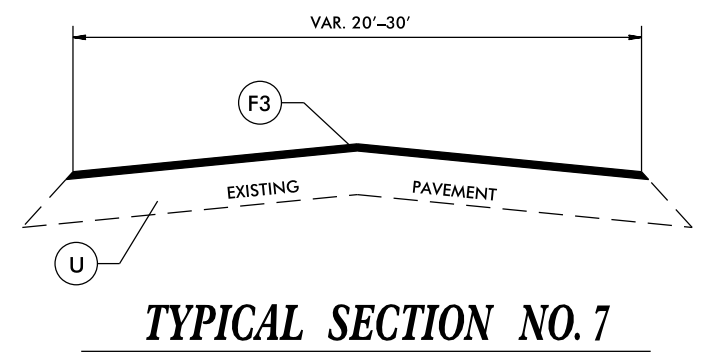
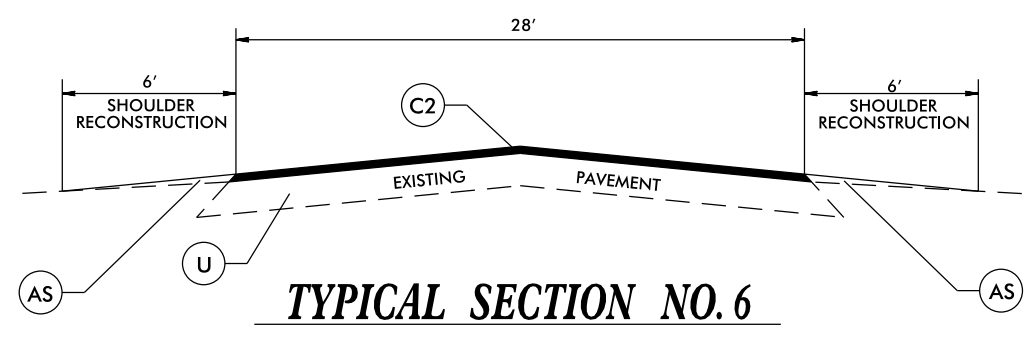

NOTE:
AT THE TERMINI, NC 49 IS DIVIDED.
THIS TYPICAL SHALL APPLY TO BOTH
SIDES OF THE DIVIDED SECTIONS

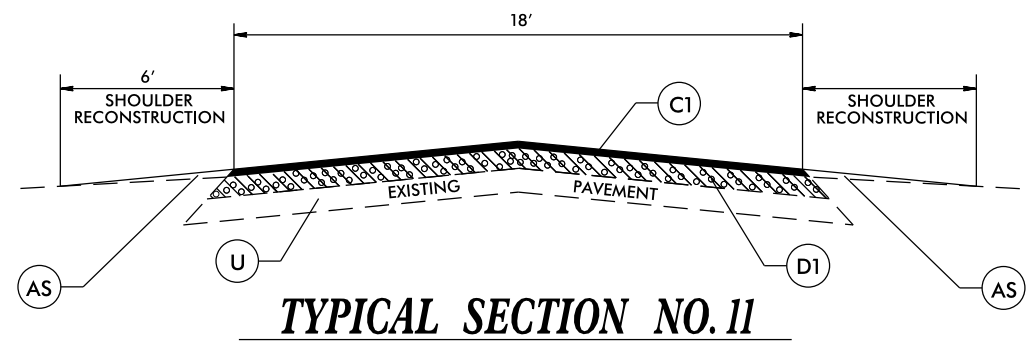
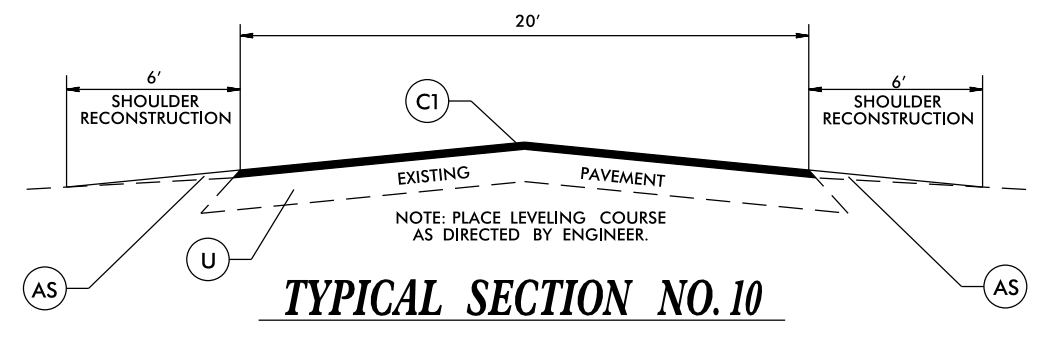
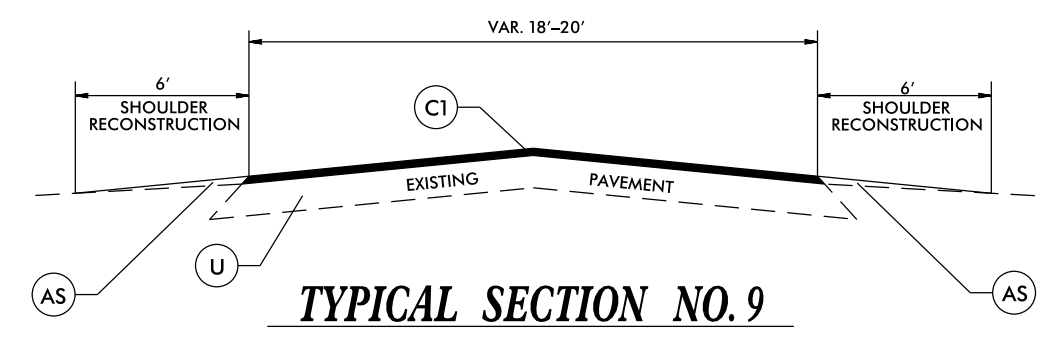
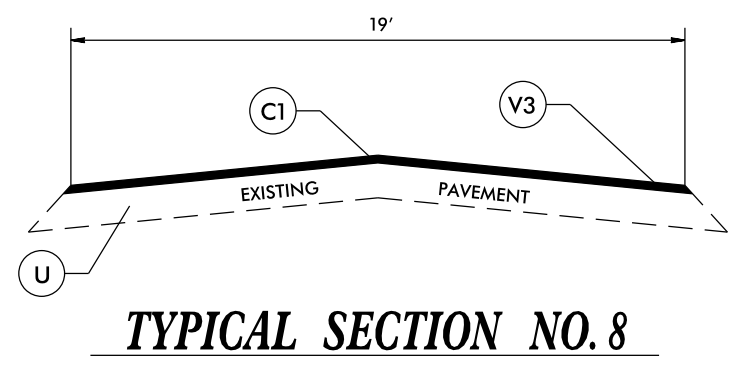

PAVEMENT SCHEDULE	
C1	PROP. APPROX. 1.25" ASPHALT CONCRETE SURFACE COURSE, TYPE SF9.5A, AT AN AVERAGE RATE OF 137.5 LBS. PER SQ. YD.
C2	PROP. APPROX. 1.5" ASPHALT CONCRETE SURFACE COURSE, TYPE S9.5B, AT AN AVERAGE RATE OF 168 LBS. PER SQ. YD.
D1	PROP. APPROX. 2.5" ASPHALT CONCRETE INTERMEDIATE COURSE, TYPE I19.0B, AT AN AVERAGE RATE OF 285LBS. PER SQ. YD.
F1	ASPHALT SURFACE TREATMENT, MAT COAT WITH #67 STONE
F3	MICROSURFACING, TYPE III
AS	AGGREGATE SHOULDER BORROW
T	EARTH MATERIAL.
U	EXISTING PAVEMENT.
V3	MILLING 1.25"

040397
 3-MAY-2016 15:19
 s:\Randolph\Projects\2016\Submittals\Montgomery-Randolph-July-2016_Typ.dgn

RANDOLPH COUNTY TYPICALS

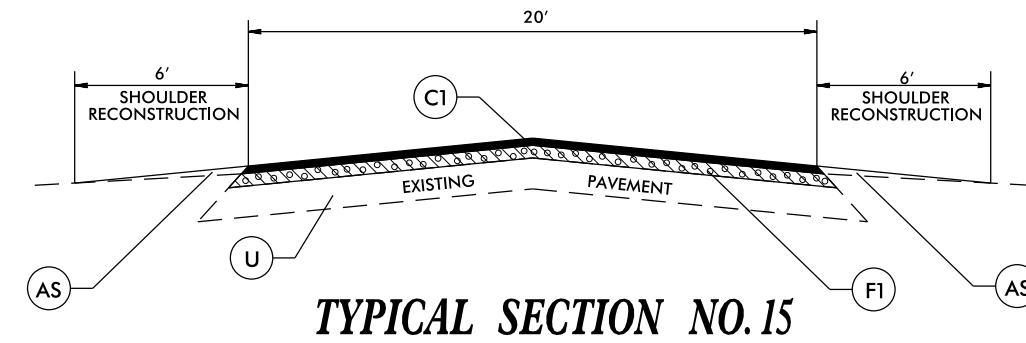
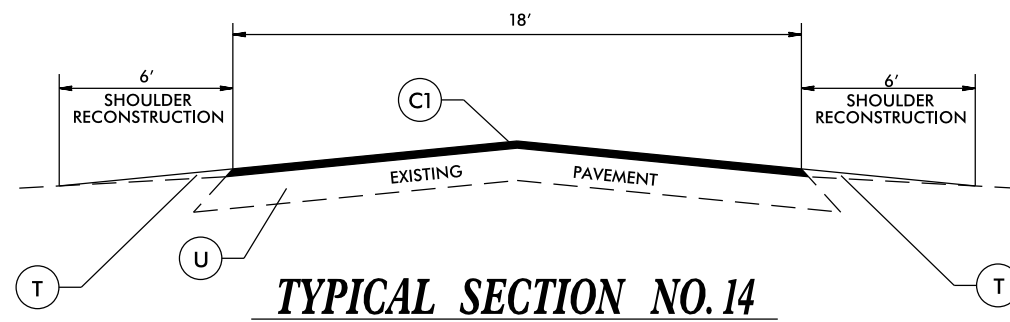
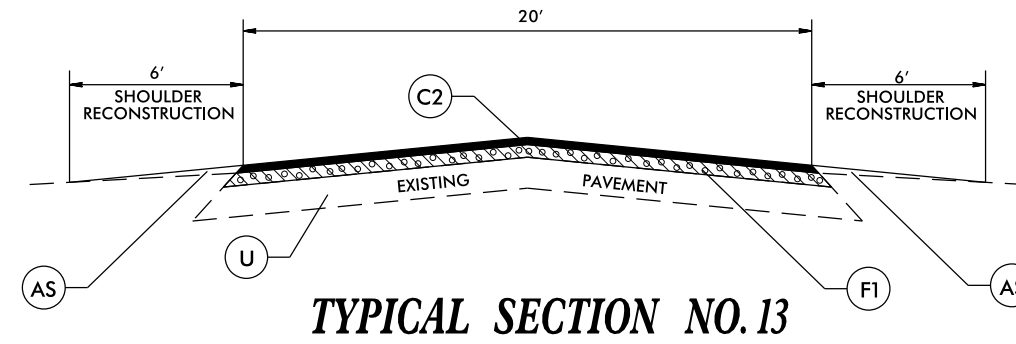
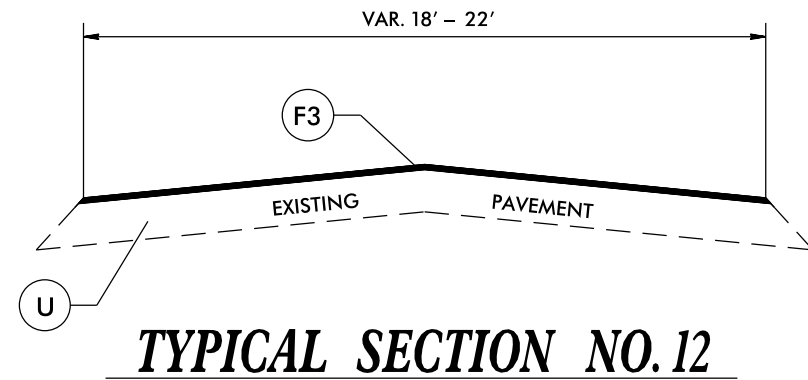

PAVEMENT SCHEDULE	
C1	PROP. APPROX. 1.25" ASPHALT CONCRETE SURFACE COURSE, TYPE SF9.5A, AT AN AVERAGE RATE OF 137.5 LBS. PER SQ. YD.
C2	PROP. APPROX. 1.5" ASPHALT CONCRETE SURFACE COURSE, TYPE S9.5B, AT AN AVERAGE RATE OF 168 LBS. PER SQ. YD.
D1	PROP. APPROX. 2.5" ASPHALT CONCRETE INTERMEDIATE COURSE, TYPE I19.0B, AT AN AVERAGE RATE OF 285LBS. PER SQ. YD.
F1	ASPHALT SURFACE TREATMENT, MAT COAT WITH #67 STONE
F3	MICROSURFACING, TYPE III
AS	AGGREGATE SHOULDER BORROW
T	EARTH MATERIAL.
U	EXISTING PAVEMENT.

RANDOLPH COUNTY TYPICALS

DETAILS OF PATCHING EXISTING PAVEMENT PRIOR TO RESURFACING

DETAIL

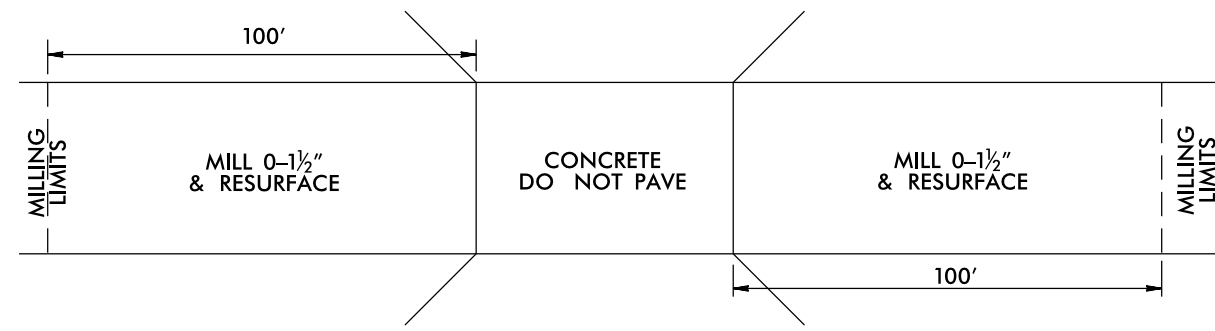
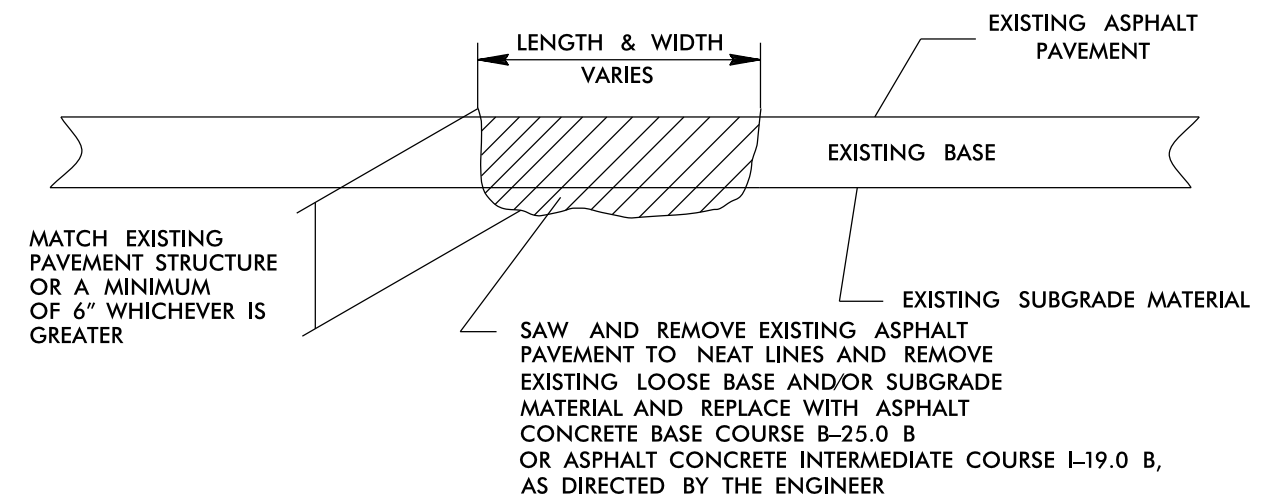

BRIDGE #s (65, 105, & 137)

USE FOR MAP #9

* MILLING SHALL BE PAID FOR UNDER INCIDENTAL MILLING

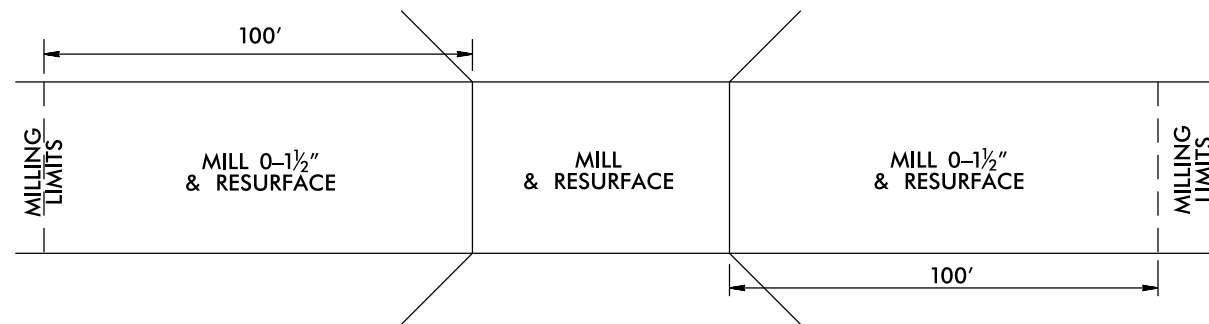

BRIDGE #'S (#30, #146)

USE FOR MAP #8, #16 RESPECTIVELY

* MILLING SHALL BE PAID FOR UNDER INCIDENTAL MILLING

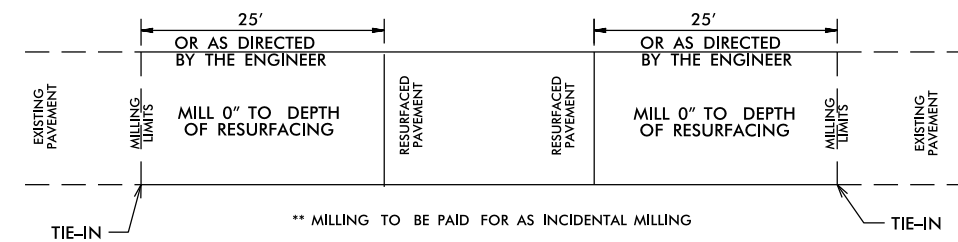

** MILLING TO BE PAID FOR AS INCIDENTAL MILLING

PAVEMENT TIE-IN DETAIL

NOTES:

- 1) DETAIL DOES NOT APPLY TO OGAFB AND ULTRA-THIN BONDED WEARING COURSE.
- 2) BACKFILL SHOULDER WITH APPROVED MATERIAL.
- 3) THE SHOULDER WEDGE DEVICE MAY BE DISENGAGED AT PAVED DRIVEWAYS, SIDE STREETS, HIGH SHOULDERS, AND OTHER LOCATIONS NOT FEASIBLE TO CONSTRUCT AS APPROVED BY THE ENGINEER.

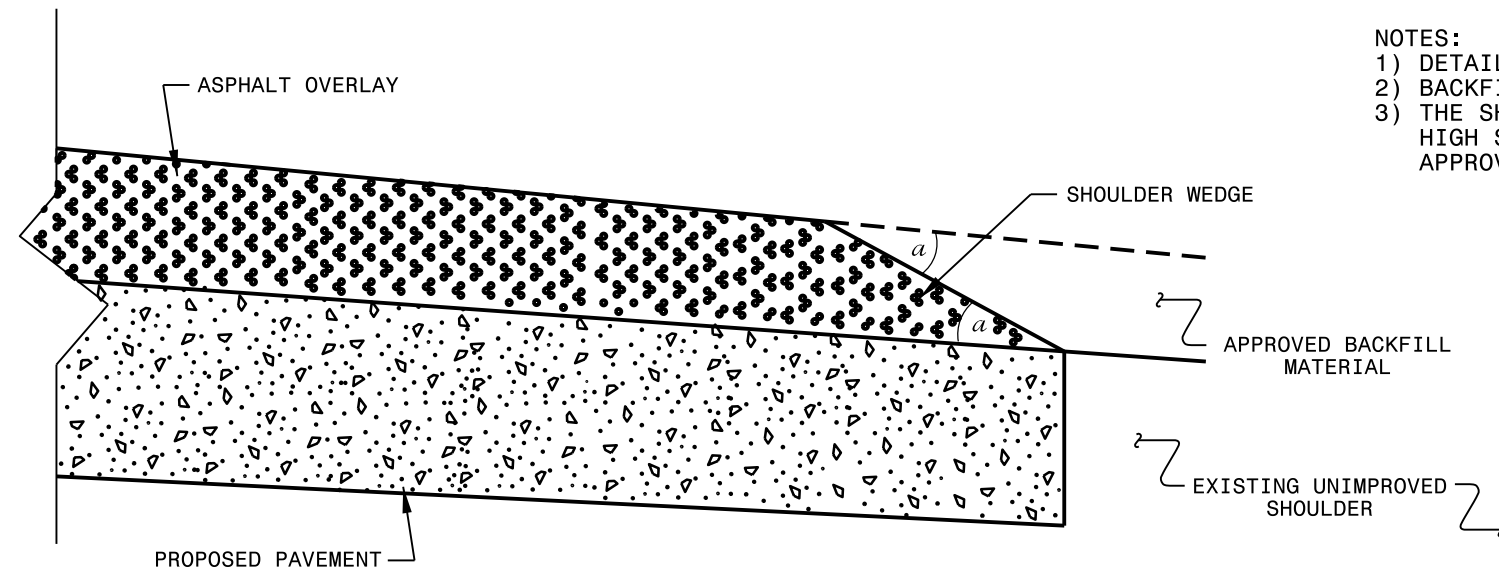

SHOULDER WEDGE DETAIL
 (Resurfacing Projects w/ Widening or
 with Existing Paved Shoulder having no dropoffs)

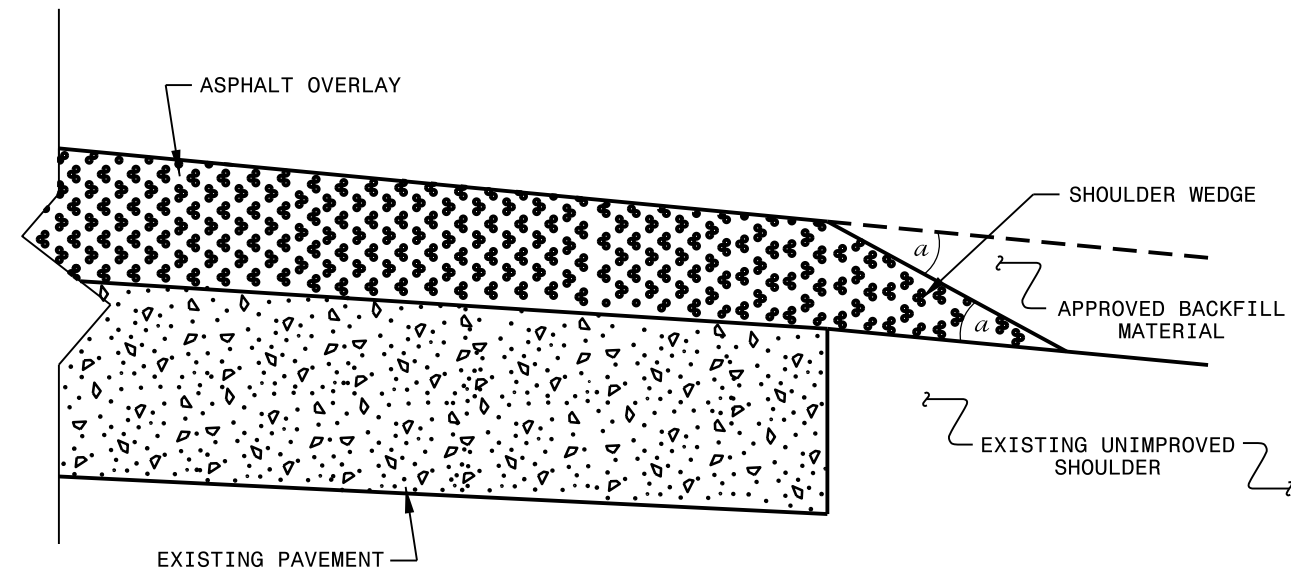

SHOULDER WEDGE DETAIL
 (Resurfacing Projects w/ NO Widening)

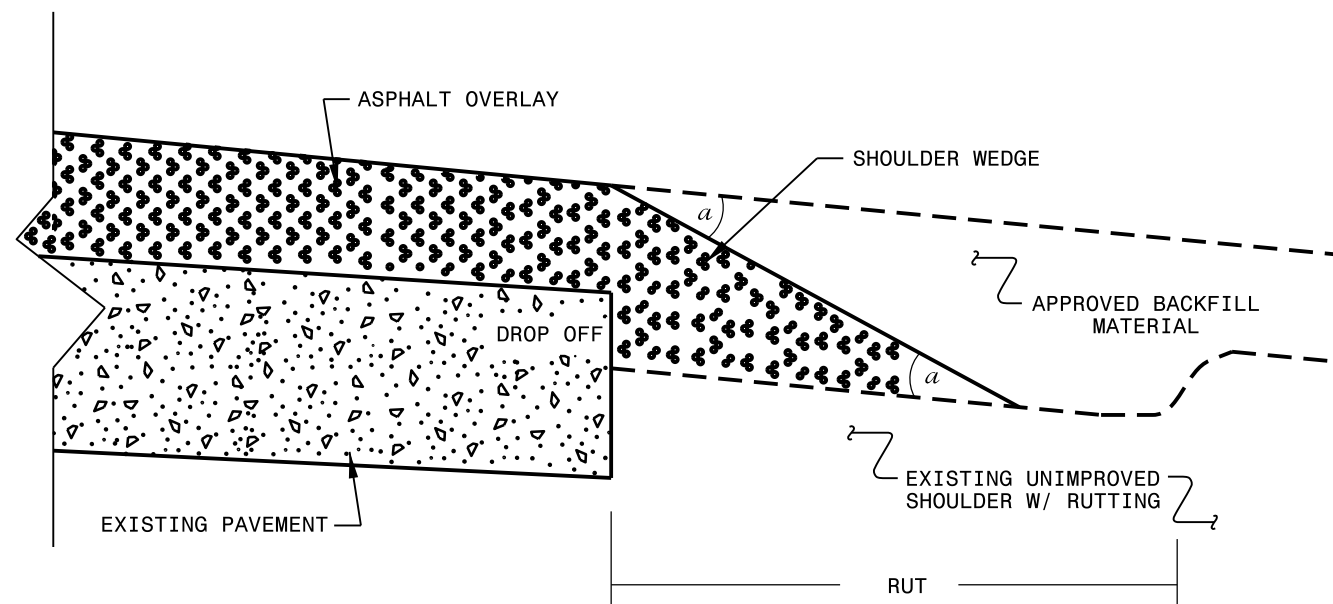

SHOULDER WEDGE DETAIL
 (Resurfacing Adjacent to
 Rutted Shoulder)

- SHOULDER WEDGE ANGLE = 30°

CONTRACT STANDARDS AND DEVELOPMENT UNIT			
Office 919-707-6950		FAX 919-250-4119	
SHOULDER WEDGE DETAILS			
ORIGINAL BY: T.SPELL	DATE: 7-19-11		
MODIFIED BY:	DATE: 2/2/16		
CHECKED BY:	DATE:		
FILE SPEC.: szusr/details/stand/shoulderwedgedetail.dgn			

24-MAR-2016 11:45
 S:\Contracts\Resurfacing Projects\Shoulder Wedge Details\Revised Shoulder Wedge Detail.dgn
 *****USERNAME*****

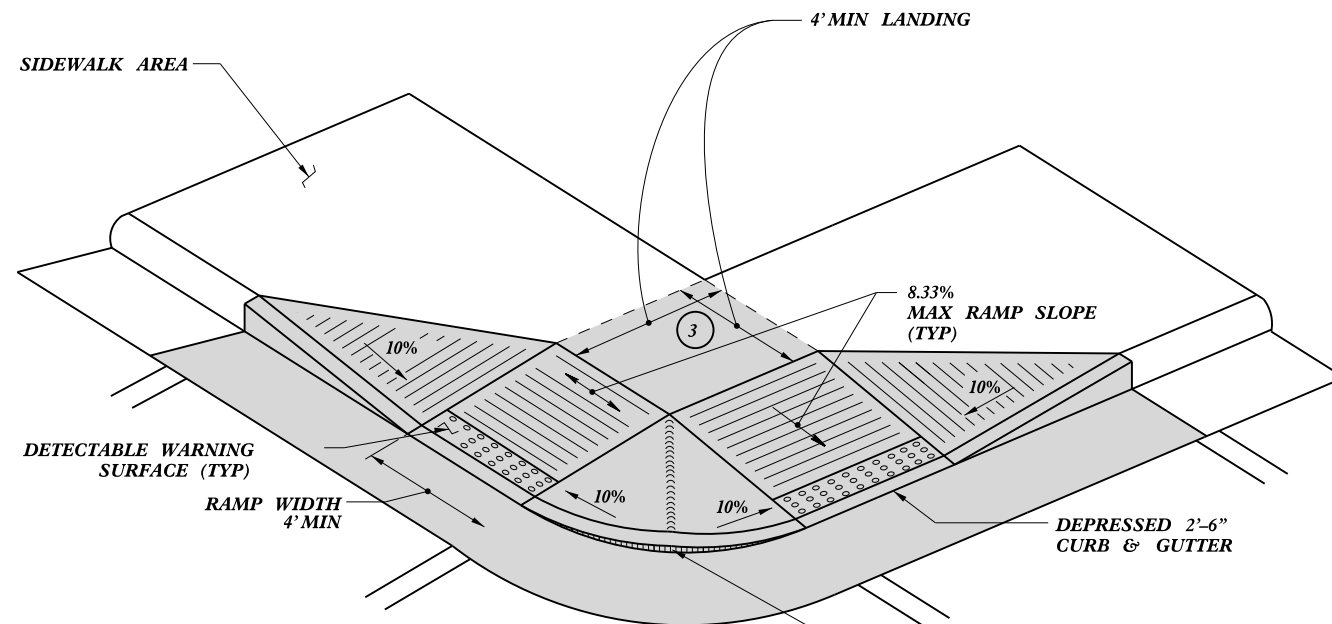

TYPE 4

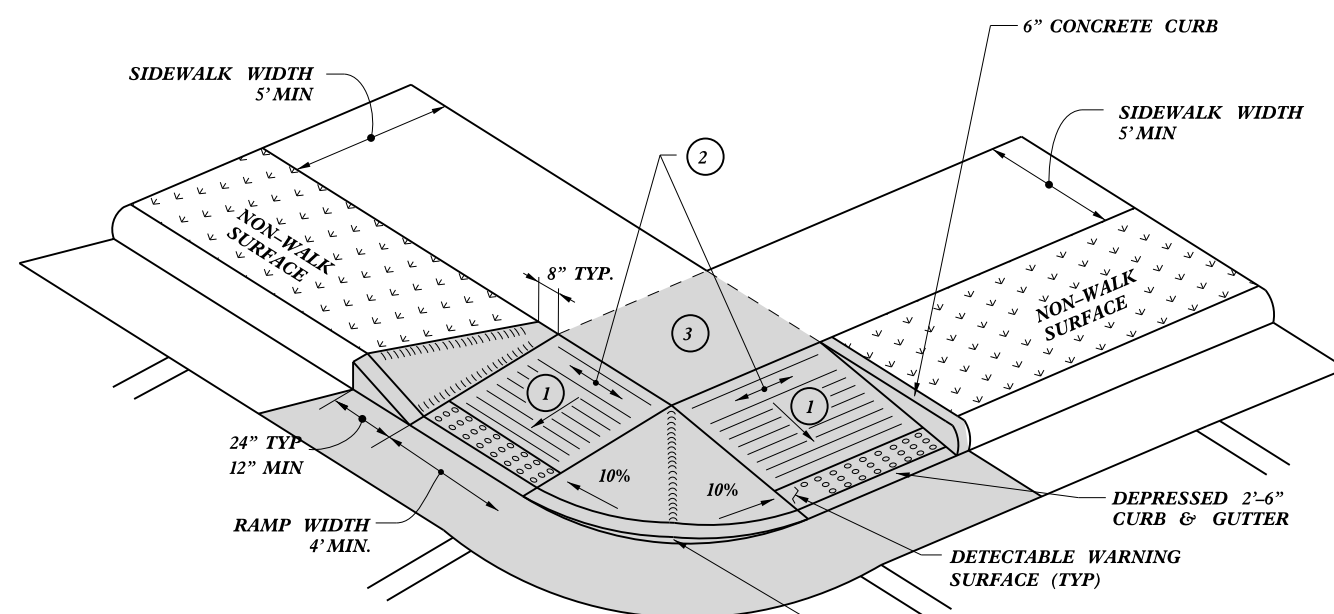

TYPE 4A

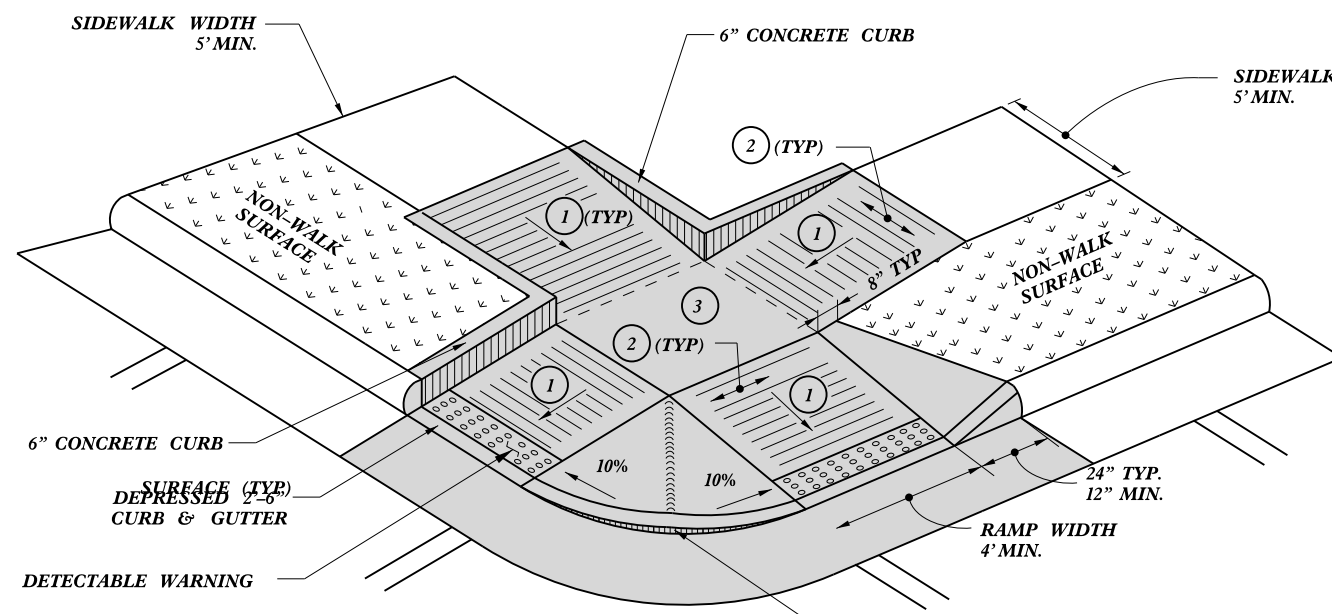

TYPE 5

PAY LIMITS FOR 2 CURB RAMPS

- 1 8.33% (12:1) MAX RAMP SLOPE
- 2 CROSS SLOPE: 2.00%
- 3 CURB RAMPS REQUIRE A (4'-0") MINIMUM LANDING WITH A MAXIMUM CROSS SLOPE AND LONGITUDINAL SLOPE OF 2.00% WHERE PEDESTRIANS PERFORM TURNING MANEUVERS. SLOPE TO DRAIN TO CURB.

DocuSigned by:
 Joel S Howerton
 449E8E25522144F...



11/18/2015

DOCUMENT NOT CONSIDERED FINAL UNLESS ALL SIGNATURES COMPLETED

CONTRACT STANDARDS AND DEVELOPMENT UNIT
 Office 919-707-6950 FAX 919-250-4119

CURB RAMPS
 Shared Landing

ORIGINAL BY: J.S. HOWERTON DATE: 7/7/11
 MODIFIED BY: DATE:
 CHECKED BY: DATE:
 FILE SPEC. :stds/2012CurbRamp/CurbRampDetails.dwg

REFER TO ROADWAY STANDARD DRAWING NUMBER 848.05 SHEET 3 OF 3 FOR ALL RAMP NOTES

5/14/1999

- 1 8.33% (12:1) MAX RAMP SLOPE
- 2 CROSS SLOPE: 2.00%
- 4 8.00% MAX CHANGE IN GRADE BETWEEN ROAD SURFACE AND DRIVEWAY

 PAY LIMITS FOR 1 CURB RAMP

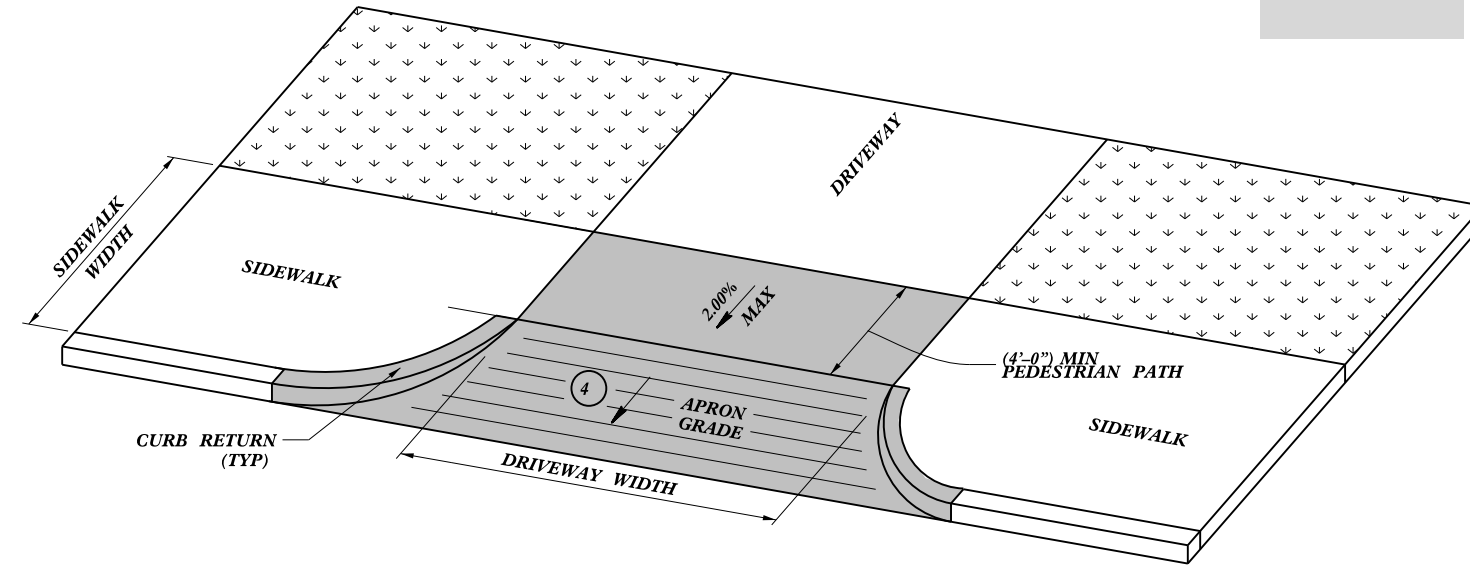

DRIVEWAY APRON
OPTION 1

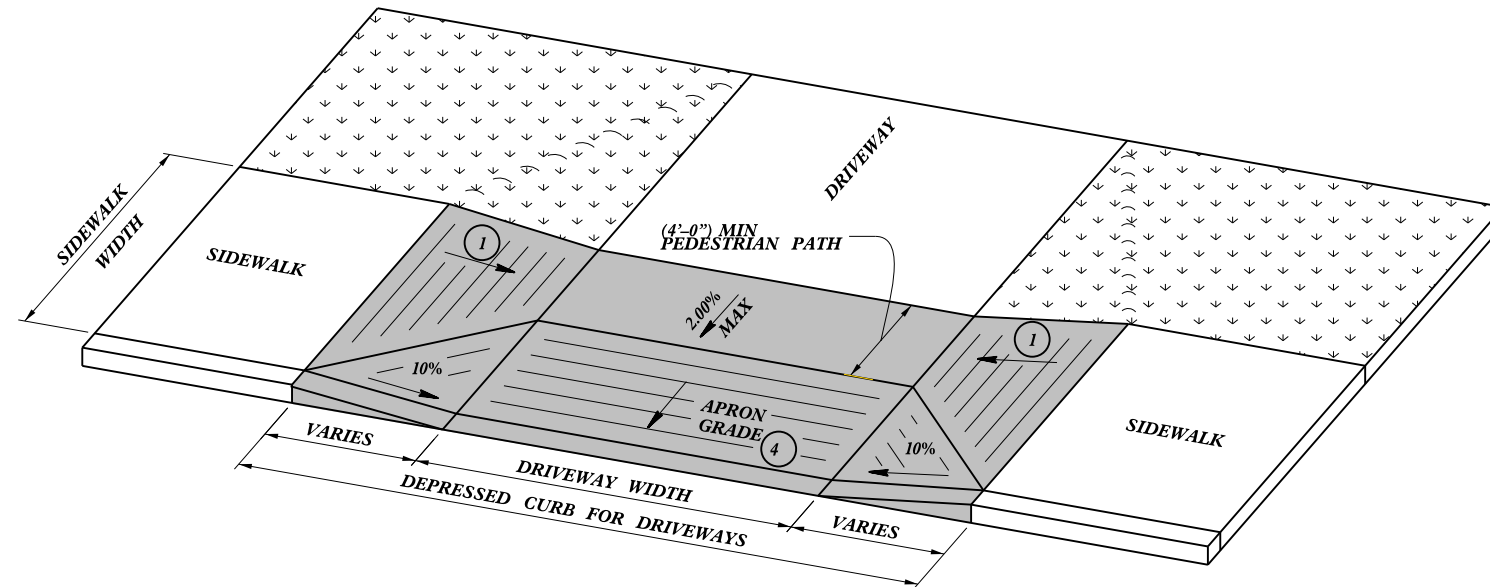

DRIVEWAY APRON
OPTION 2

-SEE ROADWAY DETAIL DRAWING 848.05 FOR DETECTABLE WARNING SURFACE AND FOR RAMP NOTES.
 -SEE ROADWAY STANDARD DRAWING 848.02 FOR CONCRETE DRIVEWAYS.

CONTRACT STANDARDS AND DEVELOPMENT UNIT	
Office 919-707-6950	FAX 919-250-4119
CURB RAMPS	
@ DRIVEWAY OPENINGS	
ORIGINAL BY: J.S. HOWERTON	DATE: 7/7/11
MODIFIED BY:	DATE:
CHECKED BY:	DATE:
FILE SPEC: sstds/2012CurbRamp/CurbRampDetails.dwg	

5/14/99
 C:\P\PROJECTS\2017\848.02\848.02.DWG

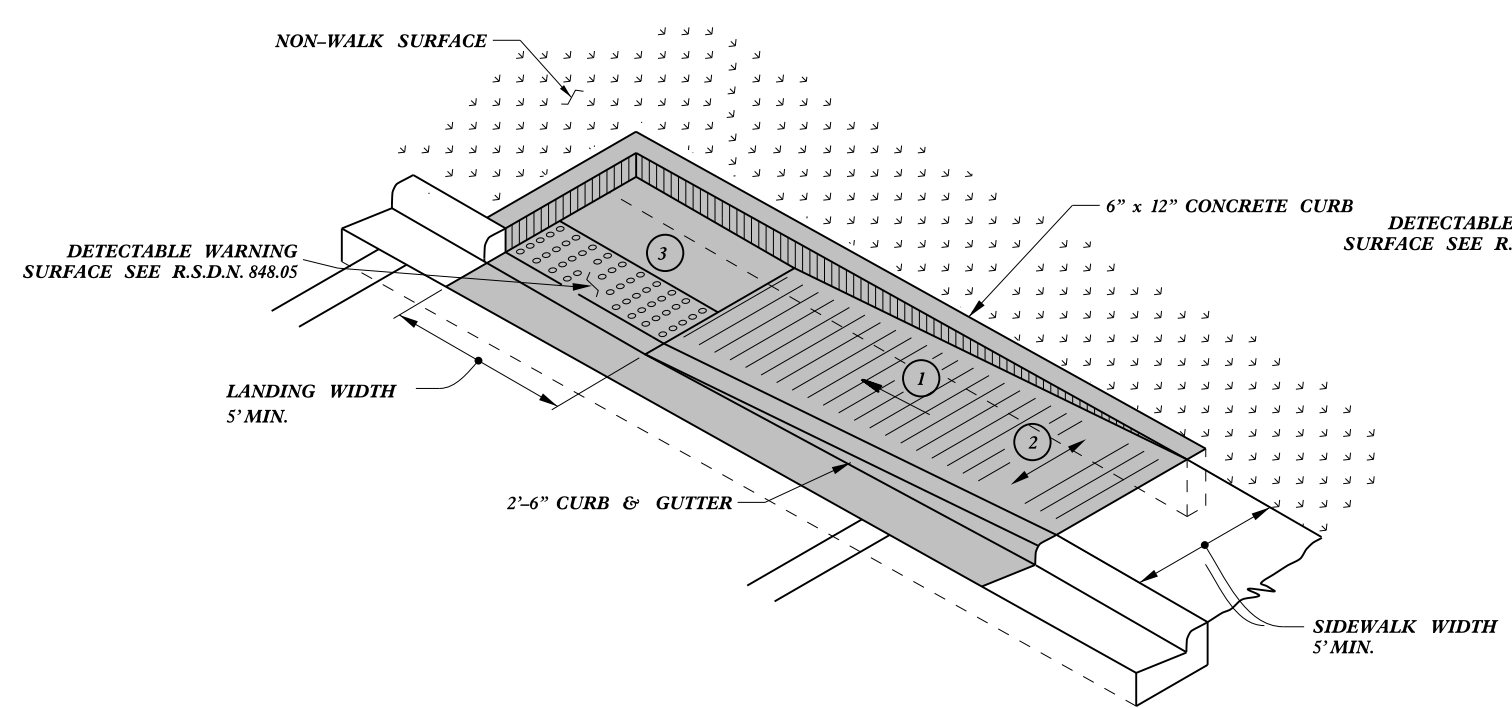

TYPE 1A

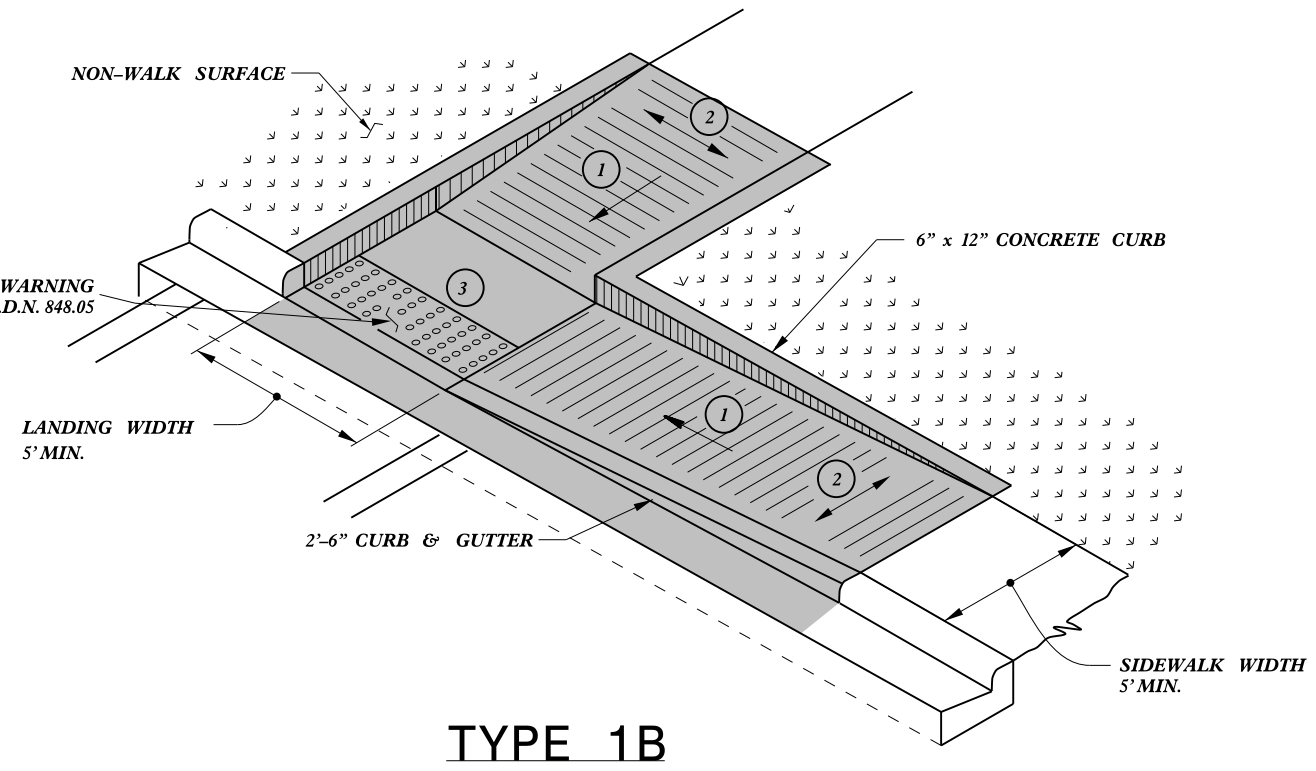

TYPE 1B

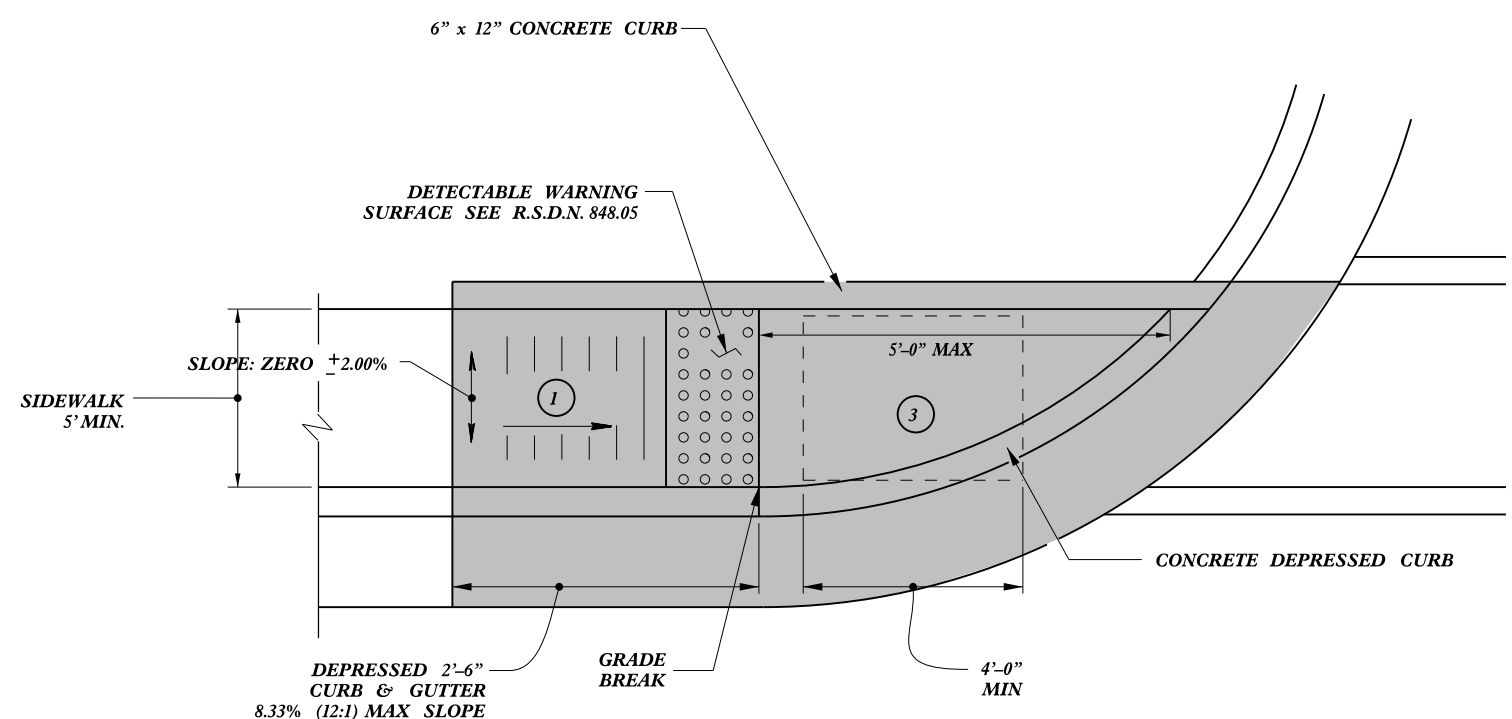

TYPE 1

PAY LIMITS FOR 1 CURB RAMP

- 1 8.33% (12:1) MAX RAMP SLOPE
- 2 CROSS SLOPE: 2.00%
- 3 CURB RAMPS REQUIRE A (4'-0") MINIMUM LANDING WITH A MAXIMUM CROSS SLOPE AND LONGITUDINAL SLOPE OF 2.00% WHERE PEDESTRIANS PERFORM TURNING MANEUVERS. SLOPE TO DRAIN TO CURB.

REFER TO ROADWAY STANDARD DRAWING NUMBER 848.05 SHEET 3 OF 3 FOR ALL RAMP NOTES



DocuSign by
 Joel S. Howerton
 449E8E25522144F...
 11/18/2015

DOCUMENT NOT CONSIDERED FINAL UNLESS ALL SIGNATURES COMPLETED

CONTRACT STANDARDS AND DEVELOPMENT UNIT	
Office 919-707-6950	FAX 919-250-4119
CURB RAMPS	
Directional Ramps	
ORIGINAL BY: J.S. HOWERTON	DATE: 7/7/11
MODIFIED BY:	DATE:
CHECKED BY:	DATE:
FILE SPEC: stds/2012CurbRamp/CurbRampDetails.dwg	

5/14/99
 1
 2
 3
 4
 5
 6
 7
 8
 9
 10
 11
 12
 13
 14
 15
 16
 17
 18
 19
 20
 21
 22
 23
 24
 25
 26
 27
 28
 29
 30
 31
 32
 33
 34
 35
 36
 37
 38
 39
 40
 41
 42
 43
 44
 45
 46
 47
 48
 49
 50
 51
 52
 53
 54
 55
 56
 57
 58
 59
 60
 61
 62
 63
 64
 65
 66
 67
 68
 69
 70
 71
 72
 73
 74
 75
 76
 77
 78
 79
 80
 81
 82
 83
 84
 85
 86
 87
 88
 89
 90
 91
 92
 93
 94
 95
 96
 97
 98
 99
 100

PROJECT NO.	SHEET NO.	TOTAL NO.
2017CPT.08.02.10621, ETC.	19	

SUMMARY OF QUANTITIES

PROJECT NO	COUNTY	MAP NO	ROUTE	DESCRIPTION	TYP	LANES	LANE TYPE	FINAL SURFACE TESTING REQUIRED	WARM MIX ASPHALT REQUIRED	LENGTH MI	WIDTH FT	BORROW EXCAVATION CY	AGGREGATE SHOULDER BORROW TON	INCIDENTAL STONE BASE TONS	SHOULDER RECONSTRUCTION SMI	2" MILLING SY	1.5" MILLING SY	1.25" MILLING SY	INCIDENTAL MILLING SY	INTERMEDIATE COURSE, I19.0B TONS	SURFACE COURSE, S9.5B TONS	LEVELING COURSE, S9.5B TONS	SURFACE COURSE, SF9.5A TON	ASPHALT BINDER FOR PLANT MIX TONS	PATCHING EXISTING PAVEMENT TONS	ASPHALT SURFACE TREATMENT, MATCOAT, #67 STONE SY	ASPHALT SURFACE TREATMENT, SINGLE SEAL SY	EMULSION FOR ASPHALT SURFACE TREATMENT GAL	LATEX MODIFIED MICRO-SURFACING, TYPE III SY				
2017CPT.08.02.10621	Montgomery	1	NC 24/27	FROM 250' W OF SR 1615 (DOGWOOD AVE) TO 660FT E OF SR 1554 (TAFT ST)	1	2	MU	NO	NO	2.315	40-47					61,120					8,075			484									
		2	NC 73	FROM NC 24 TO SR 1174 (PEE DEE DR)	2	2	2WU	NO	NO	4.32	24									400	5,650			339				60,830	21,295				
TOTAL FOR PROJ NO. 2017CPT.08.02.10621										6.635						61,120				400	13,725			823			60,830	21,295					
2017CPT.08.02.20621	Montgomery	3	SR 1005 (S MAIN ST/PEKIN RD)	FROM NC 24/27 TO END C&G SECTION 800FT S OF SR 1552 (FADUMA ST)	3	2	2WU	NO	NO	0.729	27-41						14,995				1,340			80									
		4	SR 1005 (PEKIN RD)	FROM END C&G SECTION TO SR 1519 (CAPELSIE RD)	4	2	2WU	NO	NO	0.954	21									292		1,150			69		11,755		4,702				
		5	SR 1160 (PINEHAVEN DR)	FROM SR1200 (DOGWOOD DR) TO 1ST AVE (NON-SYSTEM)	5	2	2WU	NO	NO	1.25	18													1,465	98								
		6	SR 1552 (FADUMA ST)	FROM SR 1005 (S MAIN ST) TO DEAD END	5	2	2WU	NO	NO	0.291	20-24															270	18						
		7	SR 1126 (MCKINNON RD)	FROM NC 109 TO SR 1127 (WOODYARD RD)	5	2	2WU	NO	NO	0.489	16																350	23					
TOTAL FOR PROJ NO. 2017CPT.08.02.20621										3.713						14,995			1,375	2,490		2,085	288			11,755	4,702						
2017CPT.08.02.10761	Randolph	8	US 220 BUS	FROM CONSTRUCTION JOINT OF HASKETTS CREEK BRIDGE #30 TO 0195 MI SOUTH OF BRIDGE #30	6	2	2WU	NO	NO	0.195	19		55		0.39						435			26	80								
		9	NC 49	FROM 0.20 WEST OF BRIDGE #156 OVER SR 1193 (OLD NC 49) TO SR 1193 (OLD NC 49)	7	2	2WU	NO	NO	9.094	30																					160,100	
TOTAL FOR PROJ NO. 2017CPT.08.02.10761										9.289			55		0.39						467		435	26	80						160,100		
2017CPT.08.02.20761	Randolph	10	SR 1944 (BRANSON DAVIS RD)	US 311 TO SR 2073 (WALKER MILL RD)	8	2	2WU	NO	NO	0.244	19								2,720				250	17	25								
		11	SR 2445 (BENNY LINEBERRY)	FROM SR 2261 (OLD LIBERTY RD) TO NC 22	9	2	2WU	NO	NO	2.28	20			635		4.56				110			2,035	136	113								
		12	SR 2455 (HARDIN ELLISON RD)	FROM NC 22 TO SR 2495 (MULBERRY ACADEMY ST.)	10	2	2WU	NO	NO	1.951	20				545		3.90					10	1,750	118	95								
		13	SR 2472 (SHADY GROVE CHURCH RD.)	US 64 TO SR 2470 (OLD STALEY GROVE CH RD)	11	2	2WU	NO	NO	2.8	18				780		5.60							2,250	355								
		14	SR 2472 (SHADY GROVE CHURCH RD)	FROM SR 2470 (OLD STALEY RD) TO NC 49	10	2	2WU	NO	NO	1.68	20				465		3.36						85	1,590	112	225							
		15	SR 2407 (SHILOH RD)	FROM US HWY 421 TO SR 2403 (OLD RED CROSS RD)	12	2	2WU	NO	NO	2.48	22																						32,000
		16	SR 2226 (CEDAR FALLS RD)	FROM NC 22 TO SR 2144 (WICKER LOVELL RD.)	13	2	2WU	NO	NO	1.6	20				445		3.20									105	450	19,000		7,600			
		17	SR 2495 (ACADEMY ST)	FROM SR 2500 (ACADEMY RD) TO NC 22	9	2	2WU	NO	NO	1.02	18				285		2.04								985	66	225						
		18	SR 2500 (ACADEMY RD EXT)	FROM NC 22 TO SR 2495 (MULBERRY ACADEMY)	12	2	2WU	NO	NO	1.29	18																338					13,625	
		19	SR 2557 (EMERALD DR)	FROM SR 2442 (RAMSEUR JULIAN RD) TO CUL-DE-SAC	9	2	2WU	NO	NO	0.428	20				120		0.86								385	26	180						
		20	SR 2642 (OLD SILER CITY RD)	FROM SR 2628 (PARKS CROSSROAD CHURCH RD) TO SR 2634 (OLD COLERIDGE RD)	9	2	2WU	NO	NO	3.044	18				845		6.09								2,445	164	1,450						
		21	SR 2606 (SPOONS CHAPEL RD)	FROM SR 2614 (GRANTVILLE LN) TO SR 2605 (IRON MOUNTAIN RD)	10	2	2WU	NO	NO	2.01	20				560		4.02						55	1,850	128	690							
		22	SR 2696 CANTERBURY TRL.	FROM SR 2600 (BRIARCLIFF DR) TO SR 2697 (CARRIAGE LN)	14	2	2WU	NO	NO	0.215	18			35		10	0.43								175	12	80						
		23	SR 2700 (HENLEY DR)	FROM SR 2675 (DANIEL RD) TO SR 2701 (FOREST VALLEY DR)	9	2	2WU	NO	NO	0.178	19				50		0.36								155	10							
		24	SR 2701 (FOREST VALLEY RD)	FROM SR 2700 (HENLEY DR) TO CUL-DE-SAC	9	2	2WU	NO	NO	0.15	19				45		0.30								130	9	23						
25	SR 2834 (OLD COX RD)	FROM SR 2845 (OLD NC-13) TO PVT. JT. 0.37MI S OF SR 2830 (OLD HUMBLE MILL RD)	15	2	2WU	NO	NO	3.363	20				935		6.73								3,000	201	300	39,500		15,800					
TOTAL FOR PROJ NO. 2017CPT.08.02.20761										24.733		35	5710	10	41.44			2,720	1,879	4,265	1,745	150	17,000	1,459	4,307	58,500		23,400	45,625				
GRAND TOTAL										44.37		35	5765	10	41.83	61,120	14,995	2,720	4,121	4,265	18,395	150	19,085	2,596	4,387	70,255	60,830	49,397	205,725				

PROJECT NO.	SHEET NO.	TOTAL NO.
2017CPT.08.02.10621, ETC.	20	

SUMMARY OF QUANTITIES

PROJECT NO	COUNTY	MAP NO	ROUTE	DESCRIPTION	TYP	LANES	LANE TYPE	FINAL SURFACE TESTING REQUIRED	WARM MIX ASPHALT REQUIRED	LENGTH MI	WIDTH FT	FRAME WITH GRATE & HOOD, STD 840.03, TYPE E	FRAME WITH GRATE & HOOD, STD 840.03, TYPE G	2'-6" CURB & GUTTER (STD. 846.01)	4" CONCRETE SIDEWALK (STD. 848.01)	RETROFIT EXISTING CURB RAMP (STD. 848.06)	CONCRETE CURB RAMP (STD. 848.05 or details)	ADJUST CATCH BASIN	ADJUST DROP INLET	ADJUST MANHOLES	ADJUST METER OR VALVE BOX	PORTABLE LIGHTING	TEMP SILT FENCE	WATTLE	SEED & MULCHING	INDUCTIVE LOOP SAWCUT			
NO		NO			NO					MI	FT	EA	EA	LF	SY	EA	EA	EA	EA	EA	EA	LS	LF	LF	AC	LF			
2017CPT.08.02.10621	Montgomery	1	NC 24/27	(DOGWOOD AVE) TO 660FT E OF SR 1554 (TAFT ST)	1	2	MU	NO	NO	2.315	40-47		1	40	40	13	2	1	1	19	13	*				2,100			
		2	NC 73	FROM NC 24 TO SR 1174 (PEE DEE DR)	2	2	2WU	NO	NO	4.32	24																		
TOTAL FOR PROJ NO. 2017CPT.08.02.10621										6.635			1	40	40	13	2	1	1	19	13	LS				2,100			
2017CPT.08.02.20621	Montgomery	3	SR 1005 (S MAIN ST/PEKIN RD)	SECTION 800FT S OF SR 1552 (FADUMA ST)	3	2	2WU	NO	NO	0.729	27-41	2		10	6	3	3		1	3	2	*				500			
		4	SR 1005 (PEKIN RD)	FROM END C&G SECTION TO SR 1519 (CAPELSIE RD)	4	2	2WU	NO	NO	0.954	21																		
		5	SR 1160 (PINEHAVEN DR)	FROM SR1200 (DOGWOOD DR) TO 1ST AVE (NON-SYSTEM)	5	2	2WU	NO	NO	1.25	18																		
		6	SR 1552 (FADUMA ST)	FROM SR 1005 (S MAIN ST) TO DEAD END	5	2	2WU	NO	NO	0.291	20-24											1							
		7	SR 1126 (MCKINNON RD)	FROM NC 109 TO SR 1127 (WOODYARD RD)	5	2	2WU	NO	NO	0.489	16																		
TOTAL FOR PROJ NO. 2017CPT.08.02.20621										3.713		2		10	6	3	3		1	4	2	LS				500			
2017CPT.08.02.10761	Randolph	8	US 220 BUS	FROM CONSTRUCTION JOINT OF HASKETTS CREEK BRIDGE #30 TO 0195 MI SOUTH OF BRIDGE #30	6	2	2WU	NO	NO	0.195	19																		
		9	NC 49	FROM 0.20 WEST OF BRIDGE #156 OVER SR 1193 (OLD NC 49) TO SR 1193 (OLD NC 49)	7	2	2WU	NO	NO	9.094	30																		
TOTAL FOR PROJ NO. 2017CPT.08.02.10761										9.289																			
2017CPT.08.02.20761	Randolph	10	SR 1944 (BRANSON DAVIS RD)	US 311 TO SR 2073 (WALKER MILL RD)	8	2	2WU	NO	NO	0.244	19																		
		11	SR 2445 (BENNY LINEBERRY)	FROM SR 2261 (OLD LIBERTY RD) TO NC 22	9	2	2WU	NO	NO	2.28	20																		
		12	SR 2455 (HARDIN ELLISON RD)	FROM NC 22 TO SR 2495 (MULBERRY ACADEMY ST.)	10	2	2WU	NO	NO	1.951	20																		
		13	SR 2472 (SHADY GROVE CHURCH RD.)	US 64 TO SR 2470 (OLD STALEY GROVE CH RD)	11	2	2WU	NO	NO	2.8	18																		
		14	SR 2472 (SHADY GROVE CHURCH RD)	FROM SR 2470 (OLD STALEY RD) TO NC 49	10	2	2WU	NO	NO	1.68	20																		
		15	SR 2407 (SHILOH RD)	FROM US HWY 421 TO SR 2403 (OLD RED CROSS RD)	12	2	2WU	NO	NO	2.48	22																		
		16	SR 2226 (CEDAR FALLS RD)	FROM NC 22 TO SR 2144 (WICKER LOVELL RD)	13	2	2WU	NO	NO	1.6	20																		
		17	SR 2495 (ACADEMY ST)	FROM SR 2500 (ACADEMY RD) TO NC 22	9	2	2WU	NO	NO	1.02	18												6						
		18	SR 2500 (ACADEMY RD EXT)	FROM NC 22 TO SR 2495 (MULBERRY ACADEMY)	12	2	2WU	NO	NO	1.29	18																		
		19	SR 2557 (EMERALD DR)	FROM SR 2442 (RAMSEUR JULIAN RD) TO CUL-DE-SAC	9	2	2WU	NO	NO	0.428	20																		
		20	SR 2642 (OLD SILER CITY RD)	FROM SR 2628 (PARKS CROSSROAD CHURCH RD) TO SR 2634 (OLD COLERIDGE RD)	9	2	2WU	NO	NO	3.044	18																		
		21	SR 2606 (SPOONS CHAPEL RD)	TO SR 2605 (IRON MOUNTAIN RD)	10	2	2WU	NO	NO	2.01	20																		
		22	SR 2696 CANTERBURY TRL.	FROM SR 2600 (BRIARCLIFF DR) TO SR 2697 (CARRIAGE LN)	14	2	2WU	NO	NO	0.215	18														25	15	0.31		
		23	SR 2700 (HENLEY DR)	FROM SR 2675 (DANIEL RD) TO SR 2701 (FOREST VALLEY DR)	9	2	2WU	NO	NO	0.178	19																		
		24	SR 2701 (FOREST VALLEY RD)	FROM SR 2700 (HENLEY DR) TO CUL-DE-SAC	9	2	2WU	NO	NO	0.15	19																		
25	SR 2834 (OLD COX RD)	FROM SR 2845 (OLD NC-13) TO PVT. JT. 0.37MI S OF SR 2830 (OLD HUMBLE MILL RD)	15	2	2WU	NO	NO	3.363	20																				
TOTAL FOR PROJ NO. 2017CPT.08.02.20761										24.733											6	25	15	0.31					
GRAND TOTAL										44.37		2	1	50	46	16	5	1	2	23	21	1	25	15	0.31	2,600			

PROJECT NO.	SHEET NO.	TOTAL NO.
2017CPT.08.02.10621, ETC.	21	

THERMOPLASTIC AND PAINT QUANTITIES

PROJECT NO	COUNTY	MAP NO	ROUTE	DESCRIPTION	TYP NO	LANES	LANE TYPE	LENGTH	WIDTH	441300000-E	445700000-N	451000000-N	468500000-E	468600000-E			469500000-E	470500000-E	471000000-E	472100000-E					
										WORK ZONE ADVANCE/GENERAL WARNING SIGNING	TEMPORARY TRAFFIC CONTROL	LAW ENFORCEMENT	4" X 90 M WHITE THERMO	4" X 120 M WHITE THERMO	4" X 120 M YELLOW THERMO	8" X 90 M YELLOW THERMO	16" X 120 M WHITE THERMO	24" X 120 M WHITE THERMO	THERMO MSG SCHOOL 120 M	THERMO RXR 120 M	THERMO MSG STOP 120 M	THERMO MSG ONLY 120 M	THERMO MSG AHEAD 120 M		
NO		NO			NO					SF	LS	HR	LF	LF	LF	LF	LF	LF	EA	EA	EA	EA	EA		
2017CPT.08.02.10621	Montgomery	1	NC 24/27	FROM 250' W OF SR 1615 (DOGWOOD AVE) TO SR 660FT E OF SR 1554 (TAFT ST)	1	2	MU	2.315	40-47	126	*	80	1,005	1,000	28,700	300		80							
		2	NC 73	FROM NC 24 TO SR 1174 (PEE DEE DR)	2	2	2WU	4.32	24	490	*			46,485		46,485									
TOTAL FOR PROJ NO. 2017CPT.08.02.10621										616	LS	80	47,490	1,000	75,185	300		80							
													76,185		300										
2017CPT.08.02.20621	Montgomery	3	SR 1005 (S MAIN ST/PEKIN RD)	FROM NC 24/27 TO END C&G SECTION 800FT S OF SR 1552 (FADUMA ST)	3	2	2WU	0.729	27-41	85	*	80	2,600	270	11,000			100	12						
		4	SR 1005 (PEKIN RD)	FROM END C&G SECTION TO SR 1519 (CAPELSIE RD)	4	2	2WU	0.954	21	110	*			10,265		10,265									
		5	SR 1160 (PINEHAVEN DR)	FROM SR1200 (DOGWOOD DR) TO 1ST AVE (NON-SYSTEM)	5	2	2WU	1.25	18	140	*			13,450		13,450									
		6	SR 1552 (FADUMA ST)	FROM SR 1005 (S MAIN ST) TO DEAD END	5	2	2WU	0.291	20-24	35	*														
		7	SR 1126 (MCKINNON RD)	FROM NC 109 TO SR 1127 (WOODYARD RD)	5	2	2WU	0.489	16	55	*								100	50	12	4			
TOTAL FOR PROJ NO. 2017CPT.08.02.20621										3.713	LS	80	26,315	270	34,715		100	150	24	4					
													34,985										28		
2017CPT.08.02.10761	Randolph	8	US 220 BUS	FROM CONSTRUCTION JOINT OF HASKETTS CREEK BRIDGE #30 TO 0.195 MI SOUTH OF BRIDGE #30	6	2	2WU	0.195	28	30	*		2,100	275	2,850	90									
		9	NC 49	FROM 0.20 WEST OF BRIDGE #156 OVER SR 1193 (OLD NC 49) TO SR 1193 (OLD NC 49)	7	2	2WU	9.094	30	1,020	*			2,100	275	2,850	90						8		
TOTAL FOR PROJ NO. 2017CPT.08.02.10761										9.289	LS		2,100	275	2,850	90							8	8	
													3,125										8		
2017CPT.08.02.20761	Randolph	10	SR 1944 (BRANSON DAVIS RD)	US 311 TO SR 2073 (WALKER MILL RD)	8	2	2WU	0.244	19	28	*		2,625		2,625			70			4		5		
		11	SR 2445 (BENNY LINEBERRY)	FROM SR 2261 (OLD LIBERTY RD) TO NC 22	9	2	2WU	2.28	20	253	*			24,533		24,533									
		12	SR 2455 (HARDIN ELLISON RD)	FROM NC 22 TO SR 2495 (MULBERRY ACADEMY ST.)	10	2	2WU	1.951	20	220	*			20,993		2,093									
		13	SR 2472 (SHADY GROVE CHURCH RD.)	US 64 TO SR 2470 (OLD STALEY GROVE CH RD)	11	2	2WU	2.8	18	315	*			30,128		30,128									
		14	SR 2472 (SHADY GROVE CHURCH RD)	FROM SR 2470 (OLD STALEY RD) TO NC 49	10	2	2WU	1.68	20	190	*			18,077		18,077									
		15	SR 2407 (SHILOH RD)	FROM US HWY 421 TO SR 2403 (OLD RED CROSS RD)	12	2	2WU	2.48	22	280	*														
		16	SR 2226 (CEDAR FALLS RD)	FROM NC 22 TO SR 2144 (WICKER LOVELL RD)	13	2	2WU	1.6	20	180	*			17,216		17,216									
		17	SR 2495 (ACADEMY ST)	FROM SR 2500 (ACADEMY RD) TO NC 22	9	2	2WU	1.02	18	115	*			10,975		10,975			140	12					
		18	SR 2500 (ACADEMY RD EXT)	FROM NC 22 TO SR 2495 (MULBERRY ACADEMY)	12	2	2WU	1.29	18	145	*														
		19	SR 2557 (EMERALD DR)	FROM SR 2442 (RAMSEUR JULIAN RD) TO CUL-DE-SAC	9	2	2WU	0.428	20	50	*														
		20	SR 2642 (OLD SILER CITY RD)	FROM SR 2628 (PARKS CROSSROAD CHURCH RD) TO SR 2634 (OLD COLERIDGE RD)	9	2	2WU	3.044	18	340	*			32,753		32,753									
		21	SR 2606 (SPOONS CHAPEL RD)	FROM SR 2614 (GRANTVILLE LN) TO SR 2605 (IRON MOUNTAIN RD)	10	2	2WU	2.01	20	226	*			21,628		21,628									
		22	SR 2696 CANTERBURY TRL.	FROM SR 2600 (BRIARCLIFF DR) TO SR 2697 (CARRIAGE LN)	14	2	2WU	0.215	18	25	*														
		23	SR 2700 (HENLEY DR)	FROM SR 2675 (DANIEL RD) TO SR 2701 (FOREST VALLEY DR)	9	2	2WU	0.178	19	20	*														
24	SR 2701 (FOREST VALLEY RD)	FROM SR 2700 (HENLEY DR) TO CUL-DE-SAC	9	2	2WU	0.15	19	17	*																
25	SR 2834 (OLD COX RD)	FROM SR 2845 (OLD NC-13) TO PVT. JT. 0.37MI S OF SR 2830 (OLD HUMBLE MILL RD)	15	2	2WU	3.363	20	377	*				36,186		36,186			210	12		4		5		
TOTAL FOR PROJ NO. 2017CPT.08.02.20761										24.733	LS		215,114		196,214		210	12		4			5		
													196,214									21			
GRAND TOTAL									44.37		160	291,019	1,545	308,964	390	100	440	36	4	4	8	5			
													310,509		390							57			

PROJECT NO.	SHEET NO.	TOTAL NO.
2017CPT.08.02.10621, ETC.	22	

THERMOPLASTIC AND PAINT QUANTITIES

PROJECT NO	COUNTY	MAP NO	ROUTE	DESCRIPTION	TYP NO	LANES	LANE TYPE	LENGTH	WIDTH	4725000000-E						4810000000-E		4850000000-E	4860000000-E	4875000000-N	4890000000-E			4900000000-N	4905000000-N		
										THERMO STR & RT ARROW 90 M EA	THERMO LT ARROW 90 M EA	THERMO RT ARROW 90 M EA	THERMO STR ARROW 90 M EA	THERMO MERGE ARROW 90 M EA	THERMO STR & LT ARROW 90 M EA	4" WHITE PAINT LF	4" YELLOW PAINT LF	4" LINE REMOVAL LF	8" LINE REMOVAL LF	REMOVAL OF PAVEMENT MARKING SYMBOLS & CHARACTERS EA	HOT SPRAY THERMO PAVEMENT MARKING LINES 4"X 50M WHITE LF	HOT SPRAY THERMO PAVEMENT MARKING LINES 4"X 50M YELLOW LF	HOT SPRAY THERMO PAVEMENT MARKING LINES 12"X 50M YELLOW LF	YELLOW & YELLOW MARKERS EA	SNOW PLOWABLE MARKERS C & R MARKERS EA	SNOW PLOWABLE MARKERS Y & Y MARKERS EA	
2017CPT.08.02.10621	Montgomery	1	NC 24/27	FROM 250' W OF SR 1615 (DOGWOOD AVE) TO SR 660FT E OF SR 1554 (TAFT ST)	1	2	MU	2.315	40-47	3	76		1		1										41	525	
		2	NC 73	FROM NC 24 TO SR 1174 (PEE DEE DR)	2	2	2WU	4.32	24																285		
TOTAL FOR PROJ NO. 2017CPT.08.02.10621									6.635		3	76		1	1								285	41	525		
										81												566					
2017CPT.08.02.20621	Montgomery	3	SR 1005 (S MAIN ST/PEKIN RD)	FROM NC 24/27 TO END C&G SECTION 800FT S OF SR 1552 (FADUMA ST)	3	2	2WU	0.729	27-41	2	5					2900	11000										
		4	SR 1005 (PEKIN RD)	FROM END C&G SECTION TO SR 1519 (CAPELSIE RD)	4	2	2WU	0.954	21																63		
		5	SR 1160 (PINEHAVEN DR)	FROM SR1200 (DOGWOOD DR) TO 1ST AVE (NON-SYSTEM)	5	2	2WU	1.25	18																		
		6	SR 1552 (FADUMA ST)	FROM SR 1005 (S MAIN ST) TO DEAD END	5	2	2WU	0.291	20-24																		
		7	SR 1126 (MCKINNON RD)	FROM NC 109 TO SR 1127 (WOODYARD RD)	5	2	2WU	0.489	16																		
TOTAL FOR PROJ NO. 2017CPT.08.02.20621									3.713		2	5			2,900	11,000								63			
										7						13,900											
2017CPT.08.02.10761	Randolph	8	US 220 BUS	FROM CONSTRUCTION JOINT OF HASKETTS CREEK BRIDGE #30 TO 0.195 MI SOUTH OF BRIDGE #30	6	2	2WU	0.195	28		5		2												10	60	
		9	NC 49	FROM 0.20 WEST OF BRIDGE #156 OVER SR 1193 (OLD NC 49) TO SR 1193 (OLD NC 49)	7	2	2WU	9.094	30	10	26	12	26	3			203725	1625	97	102,225	101,500	1,625			400	735	
TOTAL FOR PROJ NO. 2017CPT.08.02.10761									9.289		10	31	12	28	3		203,725	1,625	97	102,225	101,500	1,625		410	795		
										84						203,725						1,205					
2017CPT.08.02.20761	Randolph	10	SR 1944 (BRANSON DAVIS RD)	US 311 TO SR 2073 (WALKER MILL RD)	8	2	2WU	0.244	19																		
		11	SR 2445 (BENNY LINEBERRY)	FROM SR 2261 (OLD LIBERTY RD) TO NC 22	9	2	2WU	2.28	20																		
		12	SR 2455 (HARDIN ELLISON RD)	FROM NC 22 TO SR 2495 (MULBERRY ACADEMY ST.)	10	2	2WU	1.951	20																		
		13	SR 2472 (SHADY GROVE CHURCH RD.)	US 64 TO SR 2470 (OLD STALEY GROVE CH RD)	11	2	2WU	2.8	18																		
		14	SR 2472 (SHADY GROVE CHURCH RD)	FROM SR 2470 (OLD STALEY RD) TO NC 49	10	2	2WU	1.68	20																		
		15	SR 2407 (SHILOH RD)	FROM US HWY 421 TO SR 2403 (OLD RED CROSS RD)	12	2	2WU	2.48	22									23,370			26,685	26,685					
		16	SR 2226 (CEDAR FALLS RD)	FROM NC 22 TO SR 2144 (WICKER LOVELL RD)	13	2	2WU	1.6	20																106		
		17	SR 2495 (ACADEMY ST)	FROM SR 2500 (ACADEMY RD) TO NC 22	9	2	2WU	1.02	18																63		
		18	SR 2500 (ACADEMY RD EXT)	FROM NC 22 TO SR 2495 (MULBERRY ACADEMY)	12	2	2WU	1.29	18									27,760			13,880	13,880					
		19	SR 2557 (EMERALD DR)	FROM SR 2442 (RAMSEUR JULIAN RD) TO CUL-DE-SAC	9	2	2WU	0.428	20																		
		20	SR 2642 (OLD SILER CITY RD)	FROM SR 2628 (PARKS CROSSROAD CHURCH RD) TO SR 2634 (OLD COLERIDGE RD)	9	2	2WU	3.044	18																		
		21	SR 2606 (SPOONS CHAPEL RD)	FROM SR 2614 (GRANTVILLE LN) TO SR 2605 (IRON MOUNTAIN RD)	10	2	2WU	2.01	20																		
		22	SR 2696 CANTERBURY TRL	FROM SR 2600 (BRIARCLIFF DR) TO SR 2697 (CARRIAGE LN)	14	2	2WU	0.215	18																		
		23	SR 2700 (HENLEY DR)	FROM SR 2675 (DANIEL RD) TO SR 2701 (FOREST VALLEY DR)	9	2	2WU	0.178	19																		
		24	SR 2701 (FOREST VALLEY RD)	FROM SR 2700 (HENLEY DR) TO CUL-DE-SAC	9	2	2WU	0.15	19																		
25	SR 2834 (OLD COX RD)	FROM SR 2845 (OLD NC-13) TO PVT. JT. 0.37MI S OF SR 2830 (OLD HUMBLE MILL RD)	15	2	2WU	3.363	20																				
TOTAL FOR PROJ NO. 2017CPT.08.02.20761									24.733							51,130			40,565	40,565		169					
										81,130												1,771					
GRAND TOTAL									44.37		15	112	12	29	3	1	2,900	11,000	254,855	1,625	97	142,790	142,065	1,625	517	451	1,320
										172						13,900						284,855					

SIGNING FOR RESURFACING PROJECTS

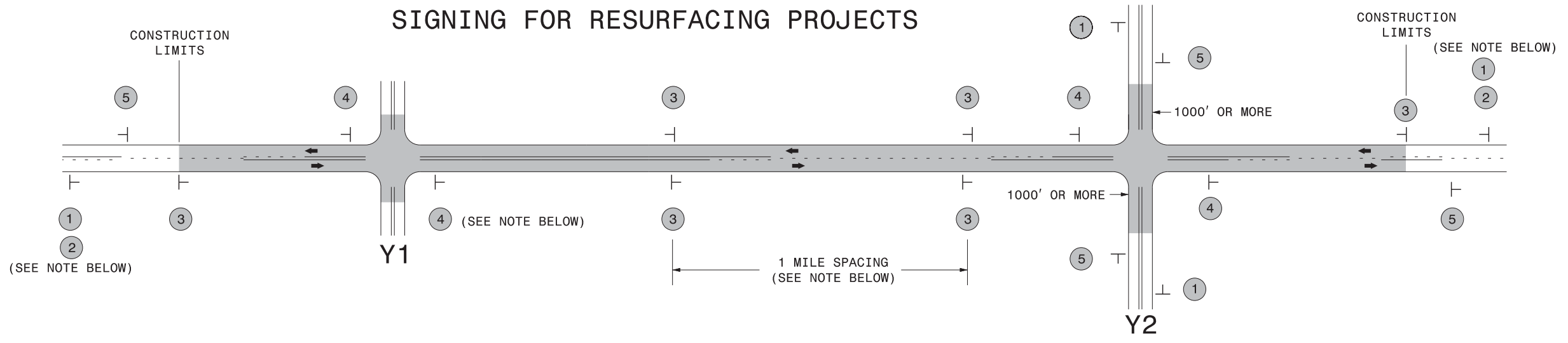

LEGEND

┆ STATIONARY SIGN

← DIRECTION OF TRAFFIC FLOW

MAINLINE (-L-) SIGNING

-Y- LINE SIGNING

SIGNING NOTES AND PLACEMENT PER DIRECTION	1	 W20-1 48" X 48"	PLACE 1000' PRIOR TO BEGINNING OF CONSTRUCTION LIMITS. ONLY USED ON -Y- LINES IF RESURFACING LIMITS EXTEND 1000' ALONG -Y- LINE.	<p>NO REQUIRED STATIONARY SIGNING FOR THE FOLLOWING -Y- LINE CONDITIONS:</p> <ol style="list-style-type: none"> LESS THAN 1000' OF RESURFACING ALONG -Y- LINE SUBDIVISION ROADS DEAD END ROADS <p>WHEN PAVING/CONSTRUCTION ACTIVITIES PROCEED ACROSS AN UNSIGNED -Y- LINE, ADVANCE WARNING PORTABLE SIGNS SHALL BE USED ALONG THE -Y- LINE AS SHOWN BELOW. REMOVE UPON COMPLETION OF WORK.</p> <div style="display: flex; justify-content: space-around;"> <div style="text-align: center;"> W20-1 48" X 48" </div> <div style="text-align: center;"> W20-7 A 48" X 48" </div> </div> <p>PLACED 500' IN ADVANCE OF FLAGGER. PLACED 250' IN ADVANCE OF FLAGGER.</p>
	2	 W7-3aP 24" X 18"	#2 SIGN ONLY USED WHEN RESURFACING LIMITS ARE 2 OR MORE MILES IN LENGTH. ROUND UP TO NEXT WHOLE NUMBER. (NO FRACTIONAL OR DECIMAL NUMBERS)	
	3	 SP 13107 48" X 48"	PLACE INITIALLY AT THE CONSTRUCTION LIMITS AND SPACED 1 MILE APART THEREAFTER. IF NO -Y- LINES EXIST, PLACE 2ND SET 1/2 MILE FROM THE CONSTRUCTION LIMITS AND THEN SPACE 1 MILE THEREAFTER.	
	4	 SP 13106 48" X 48"	THESE ARE FOR -Y- LINES THAT ARE "THROUGH" ROADWAYS. DEAD END AND SUBDIVISION ROADS ARE NOT "THROUGH" ROADWAYS. INSTALL 500' +/- FROM EACH -Y- LINE APPROACH AS SHOWN ABOVE. FOR MULTIPLE -Y- LINES THAT ARE SEPARATED BY 0.25 MILES OR LESS, TREAT AS A SINGLE UNIT AND INSTALL WITHIN 500' OF EACH APPROACH. A MAXIMUM OF 2 SIGN SETS PER MILE. DO NOT INSTALL WHEN -Y- LINES ARE WITHIN 0.5 MILES FROM "END ROAD WORK" SIGN.	
	5	 G20-2 A 48" X 24"	PLACE 500' FOLLOWING THE END OF CONSTRUCTION LIMITS.	

**RESURFACING
 ADVANCE WARNING SIGNS
 FOR
 RURAL AND SUBURBAN
 2 LANE ROADWAYS**

3/19/2015 C:\Users\rmgarrett\Downloads\Resurfacing_AdvWarn.2Ln (2).dgn User:rmgarrett

SIGNING FOR ASPHALT SURFACE TREATMENT

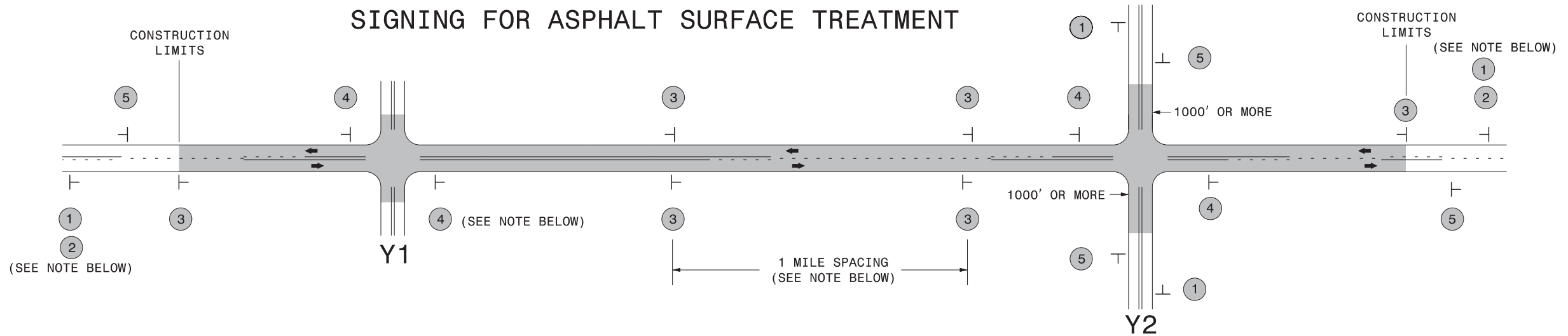

LEGEND

┆ STATIONARY SIGN

← DIRECTION OF TRAFFIC FLOW

MAINLINE (-L-) SIGNING

-Y- LINE SIGNING

SIGNING NOTES AND PLACEMENT PER DIRECTION	 	<p>PLACE 1000' PRIOR TO BEGINNING OF CONSTRUCTION LIMITS. ONLY USED ON -Y- LINES IF RESURFACING LIMITS EXTEND 1000' ALONG -Y- LINE.</p> <p>#2 SIGN ONLY USED WHEN RESURFACING LIMITS ARE 2 OR MORE MILES IN LENGTH. ROUND UP TO NEXT WHOLE NUMBER. (NO FRACTIONAL OR DECIMAL NUMBERS)</p>	<p>NO REQUIRED STATIONARY SIGNING FOR THE FOLLOWING -Y- LINE CONDITIONS:</p> <ol style="list-style-type: none"> 1) LESS THAN 1000' OF RESURFACING ALONG -Y- LINE 2) SUBDIVISION ROADS 3) DEAD END ROADS <p>WHEN PAVING/CONSTRUCTION ACTIVITIES PROCEED ACROSS AN UNSIGNED -Y- LINE, ADVANCE WARNING PORTABLE SIGNS SHALL BE USED ALONG THE -Y- LINE AS SHOWN BELOW. REMOVE UPON COMPLETION OF WORK.</p> <div style="display: flex; justify-content: space-around;"> <div style="text-align: center;"> <small>W20-1 48" X 48"</small> </div> <div style="text-align: center;"> <small>W20-7 A 48" X 48"</small> </div> </div> <p>PLACED 500' IN ADVANCE OF FLAGGER. PLACED 250' IN ADVANCE OF FLAGGER.</p>
	 	<p>ALTERNATE THE FOLLOWING TWO SIGNS:</p> <p>STARTING WITH "LOOSE GRAVEL" (W8-7) FOLLOWED BY "UNMARKED PAVEMENT".</p> <p>PLACE INITIALLY AT THE CONSTRUCTION LIMITS AND SPACED 1 MILE APART THEREAFTER. IF NO -Y- LINES EXIST, PLACE 2ND SET 1/2 MILE FROM THE CONSTRUCTION LIMITS AND THEN SPACE 1 MILE THEREAFTER.</p>	
		<p>THESE ARE FOR -Y- LINES THAT ARE "THROUGH" ROADWAYS. DEAD END AND SUBDIVISION ROADS ARE NOT "THROUGH" ROADWAYS. INSTALL 500' +/- FROM EACH -Y- LINE APPROACH AS SHOWN ABOVE. FOR MULTIPLE -Y- LINES THAT ARE SEPARATED BY 0.25 MILES OR LESS, TREAT AS A SINGLE UNIT AND INSTALL WITHIN 500' OF EACH APPROACH. A MAXIMUM OF 2 SIGN SETS PER MILE. DO NOT INSTALL WHEN -Y- LINES ARE WITHIN 0.5 MILES FROM "END ROAD WORK" SIGN.</p>	
		<p>PLACE 500' FOLLOWING THE END OF CONSTRUCTION LIMITS.</p>	

ADVANCE WARNING SIGNS FOR ASPHALT SURFACE TREATMENTS 2 LANE ROADWAYS

12/22/2014 S:\TMU\WZTC\apps\work\zonegeneral\externalwebpage\desres\resurfacing\resurfacing_advwarn_2Ln - AST.dgn User:rmgarratt

NOTES: Less than 5' - 10' undisturbed buffer from ROW, ditchline, water feature, or drainage inlet, add BMP.

BMP Options: Wattle, Silt Fence or Hardened Aggregate.

EROSION CONTROL DETAIL

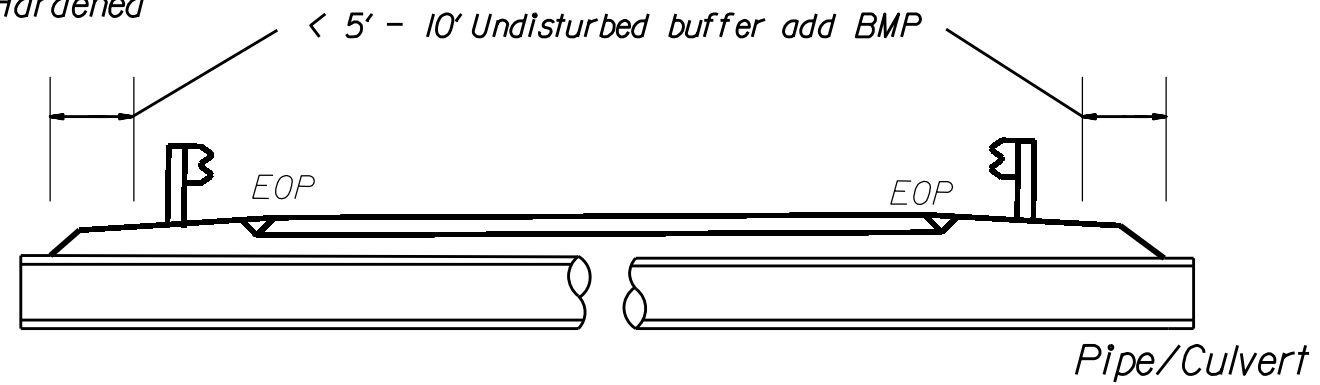

< 5' - 10' Undisturbed buffer from jurisdictional feature add BMP

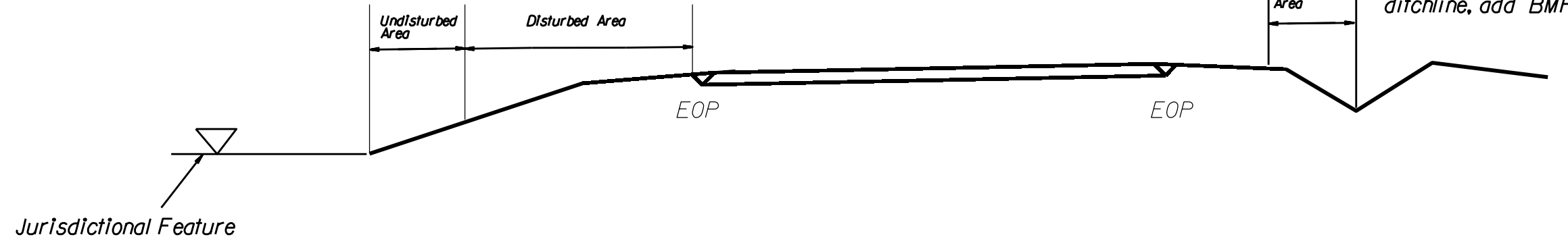

Use BMP's if shoulders and/or frontslopes and/or ditchline and/or backslopes are disturbed

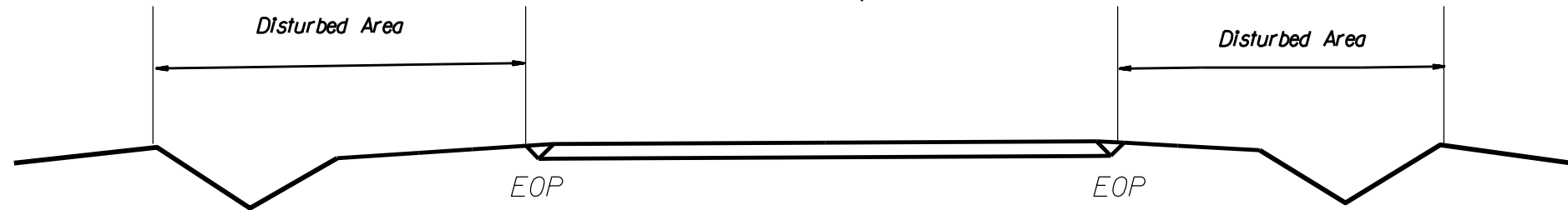

< 5' - 10' Undisturbed buffer from inlet, add wattle

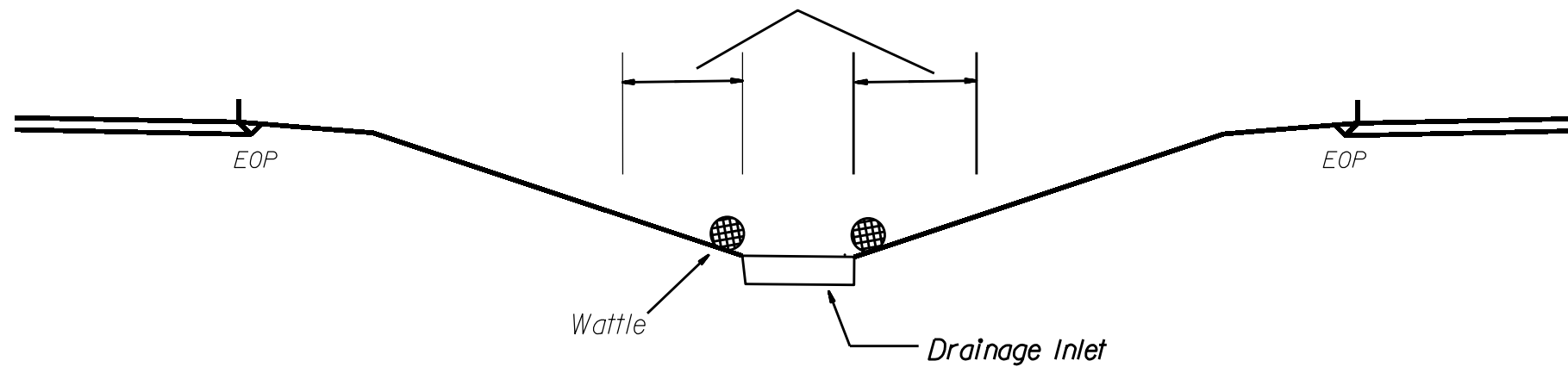

NOT TO SCALE

WATTLE DETAIL

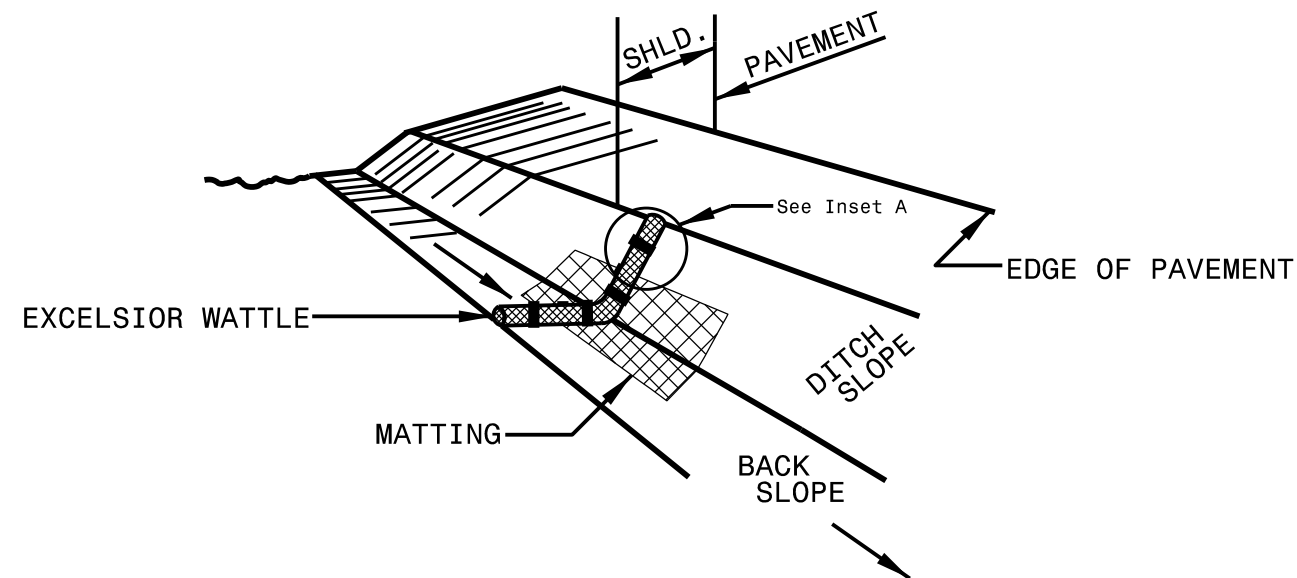

ISOMETRIC VIEW

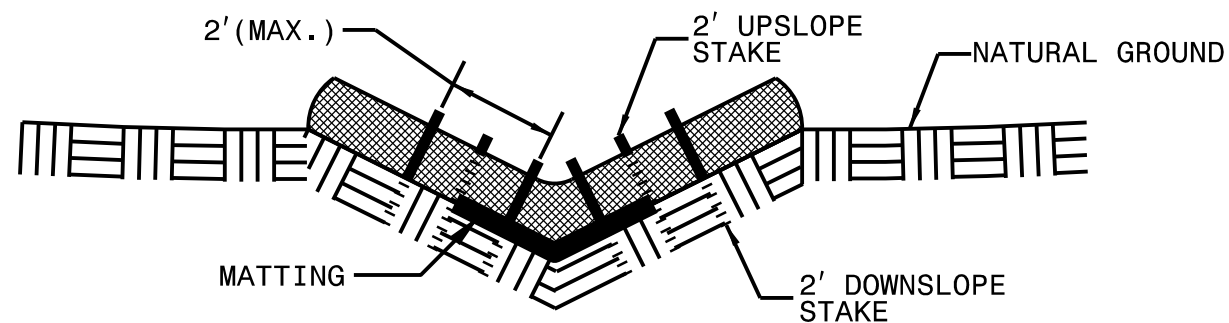

**CROSS SECTION
VEE DITCH**

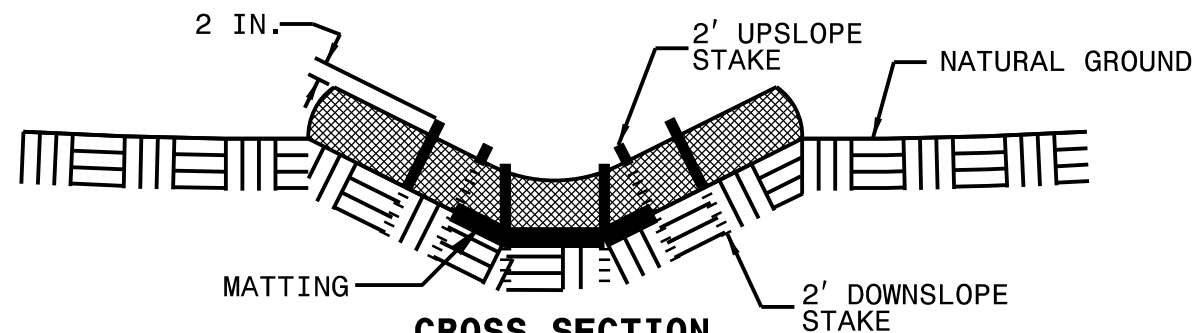

**CROSS SECTION
TRAPEZOIDAL DITCH**

NOTES:

USE MINIMUM 12 IN. DIAMETER EXCELSIOR WATTLE.

USE 2 FT. WOODEN STAKES WITH A 2 IN. BY 2 IN. NOMINAL CROSS SECTION.

ONLY INSTALL WATTLE(S) TO A HEIGHT IN DITCH SO FLOW WILL NOT WASH AROUND WATTLE AND SCOUR DITCH SLOPES AND AS DIRECTED.

INSTALL A MINIMUM OF 2 UPSLOPE STAKES AND 4 DOWNSLOPE STAKES AT AN ANGLE TO WEDGE WATTLE TO BOTTOM OF DITCH.

PROVIDE STAPLES MADE OF 0.125 IN. DIAMETER STEEL WIRE FORMED INTO A U SHAPE NOT LESS THAN 12" IN LENGTH.

INSTALL STAPLES APPROXIMATELY EVERY 1 LINEAR FOOT ON BOTH SIDES OF WATTLE AND AT EACH END TO SECURE IT TO THE SOIL.

INSTALL MATTING IN ACCORDANCE WITH SECTION 1631 OF THE STANDARD SPECIFICATIONS.



INSET A

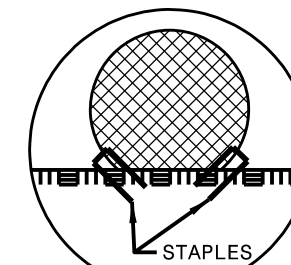

INSET B

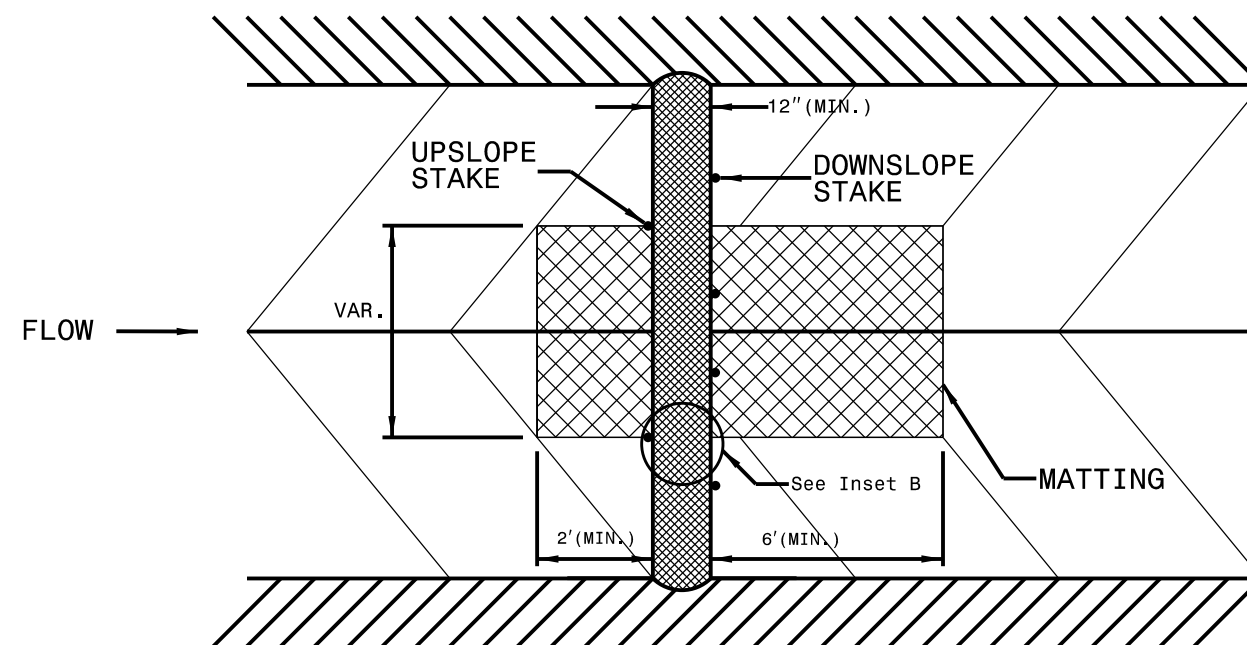

TOP VIEW

High Speed Detection (≥40 mph)

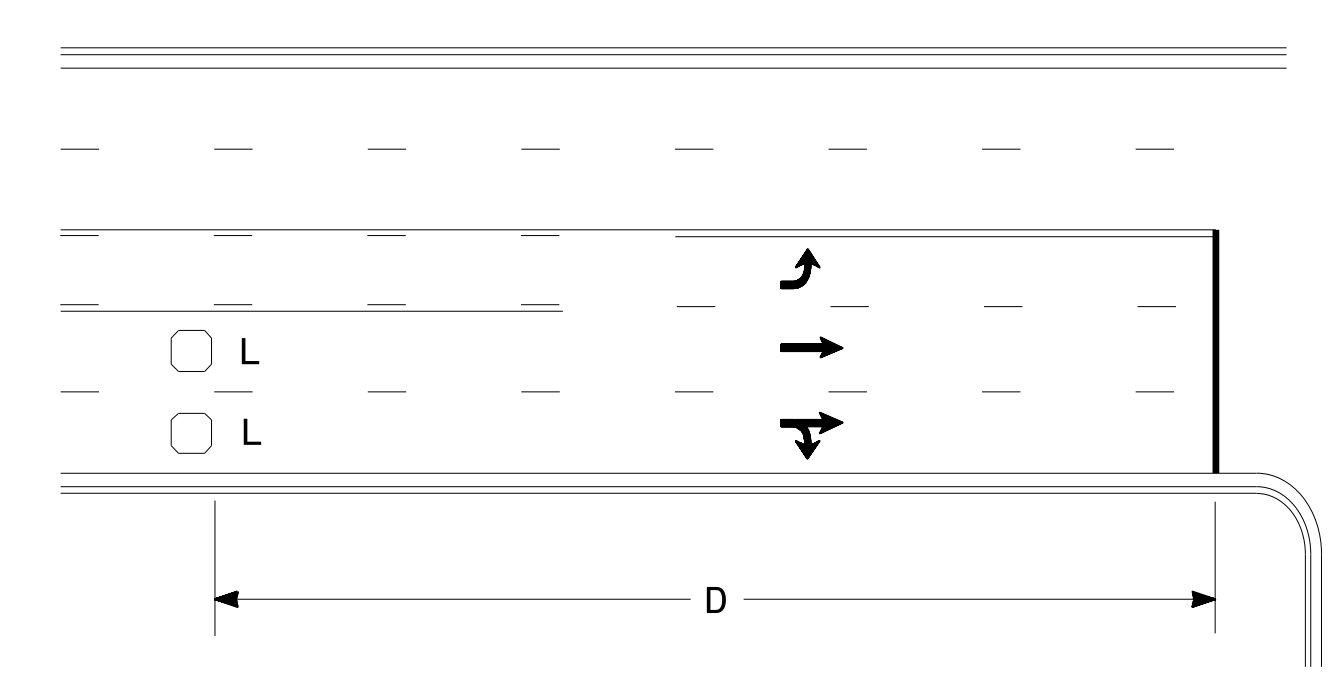

Speed Limit mph	D ft
40	250
45	300
50	355
55	420

L = 6ft X 6ft
 Wired in series for TS1
 Controllers
 Wired separately for TS2,
 170, and 2070L Controllers

Volume Density Operation

OR

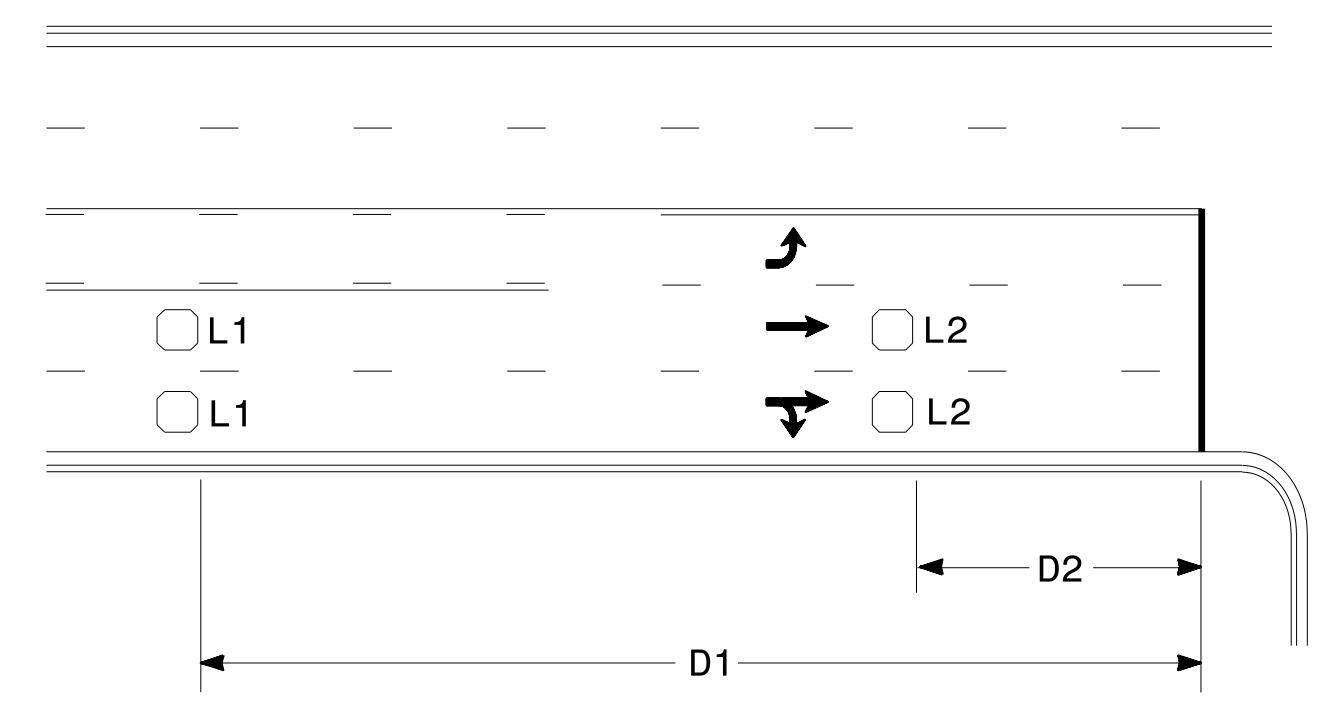

Speed Limit mph	D1 ft	D2 ft
40	250	80
45	300	90
50	355	100
55	420	110

L1 = 6ft X 6ft
 Wired in series
 L2 = 6ft X 6ft
 Wired in series

"Stretch" Operation

Low Speed Detection (≤35 mph)

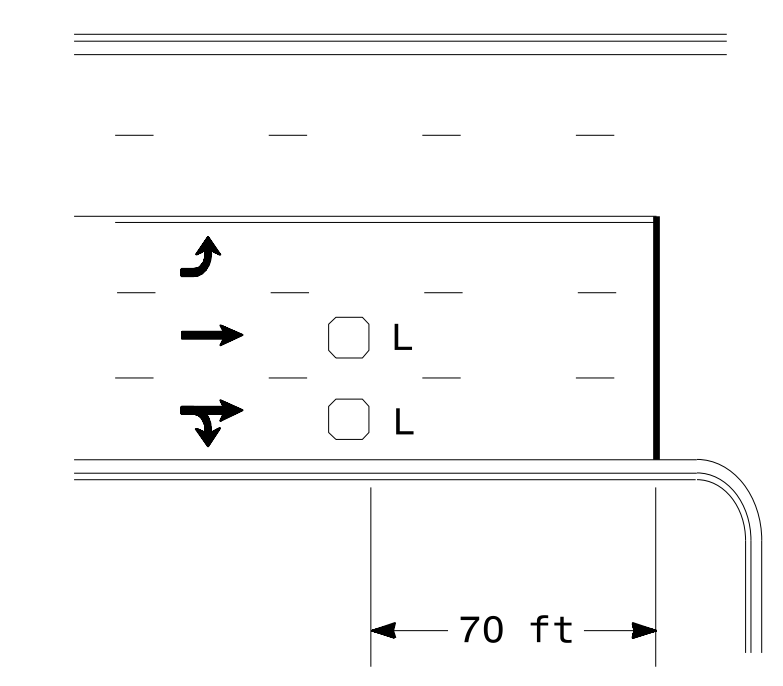

L = 6ft X 6ft
 Wired in series

OR

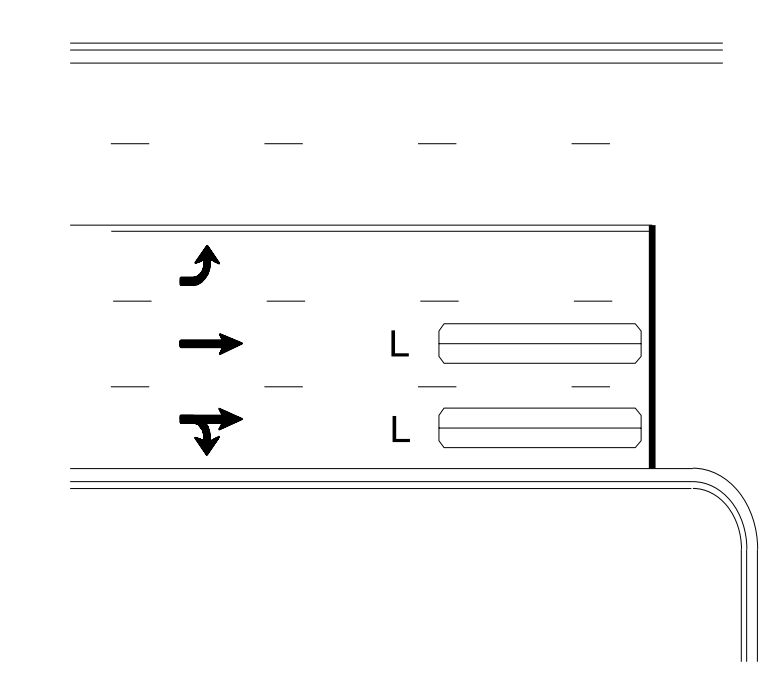

L = 6ft X 40ft
 Quadrupole loop, wired separately

Left Turn Lane Detection

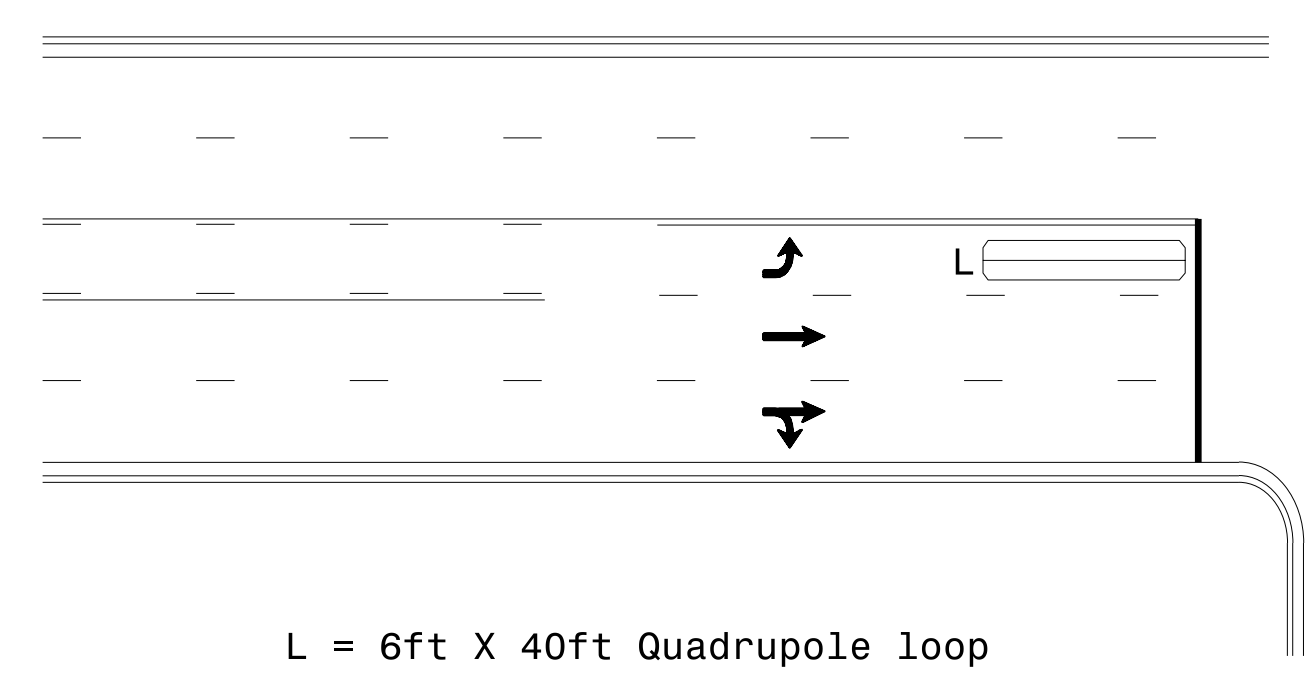

L = 6ft X 40ft Quadrupole loop

Presence Loop Detection

OR

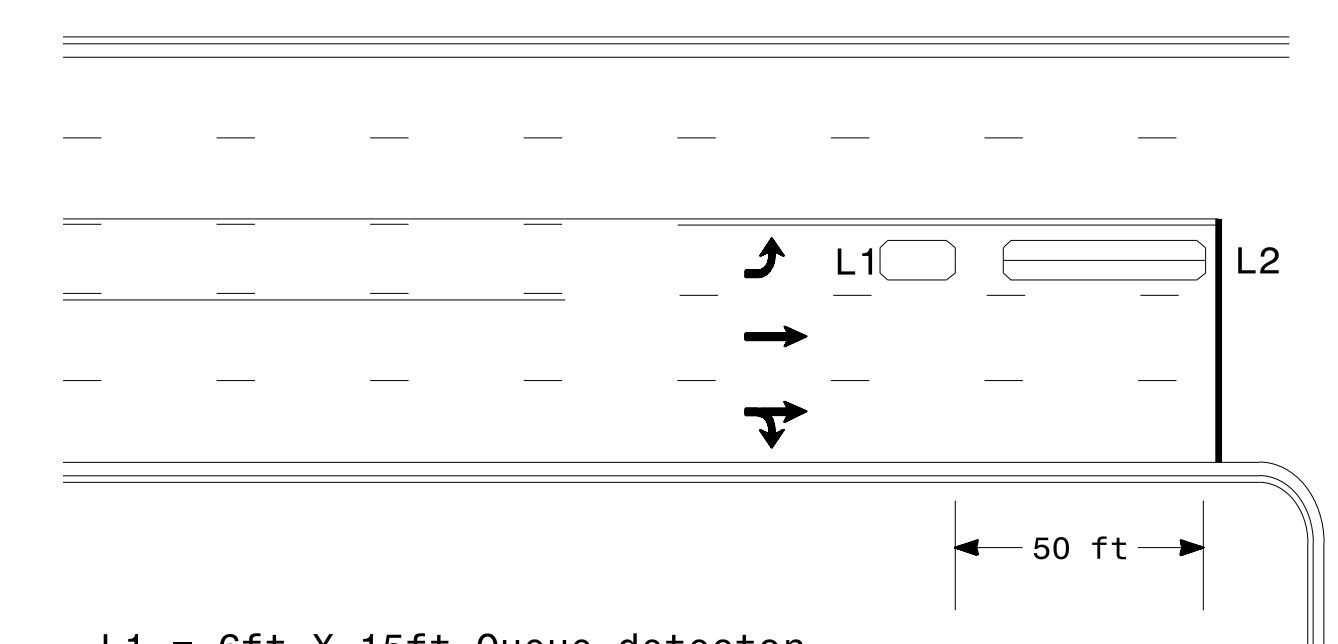

L1 = 6ft X 15ft Queue detector
 L2 = 6ft X 40ft Quadrupole loop

Queue Loop Detection

Right Turn Lane Detection

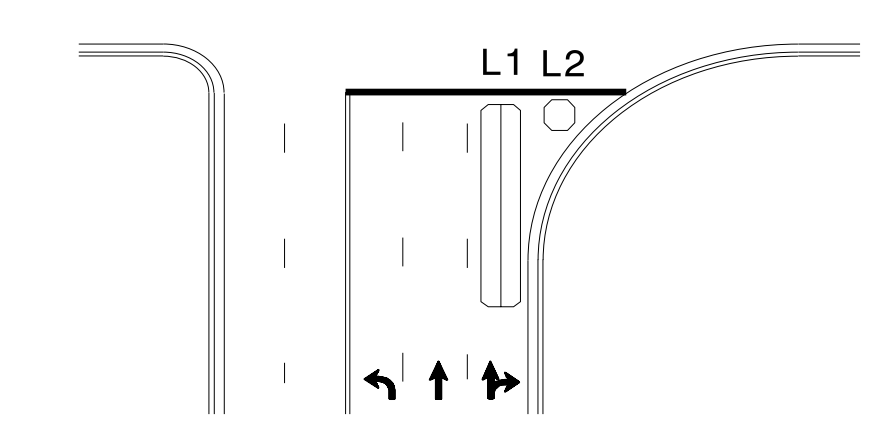

Shared Lane/
Wide Radius Turn

L1 = 6ft X 40ft Quadrupole loop
 L2 = 6ft X 6ft [Minimum] Presence loop
 Wired separately

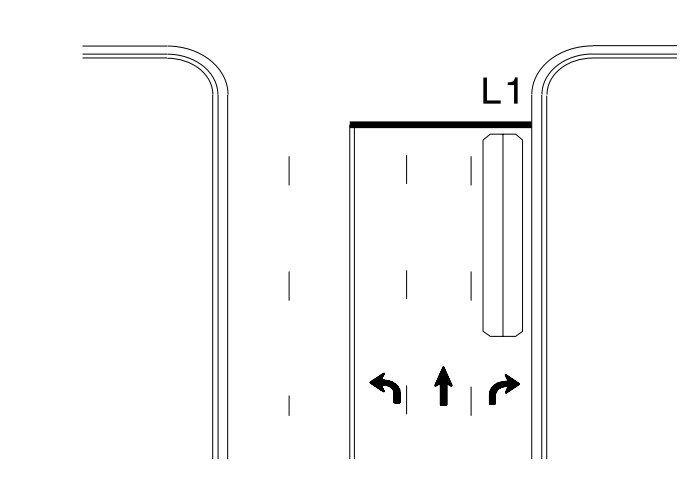

Standard Turn

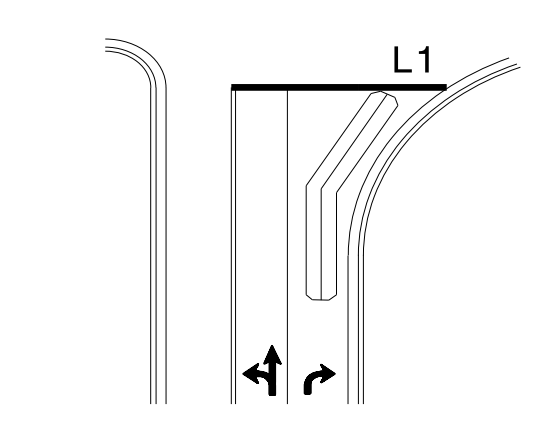

Wide Radius Turn

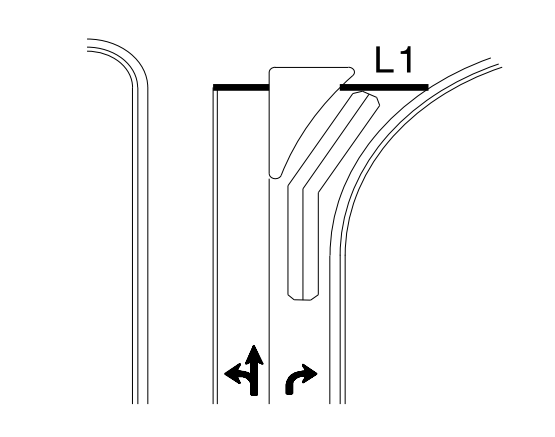

Channelized Turn

Side Street Detection

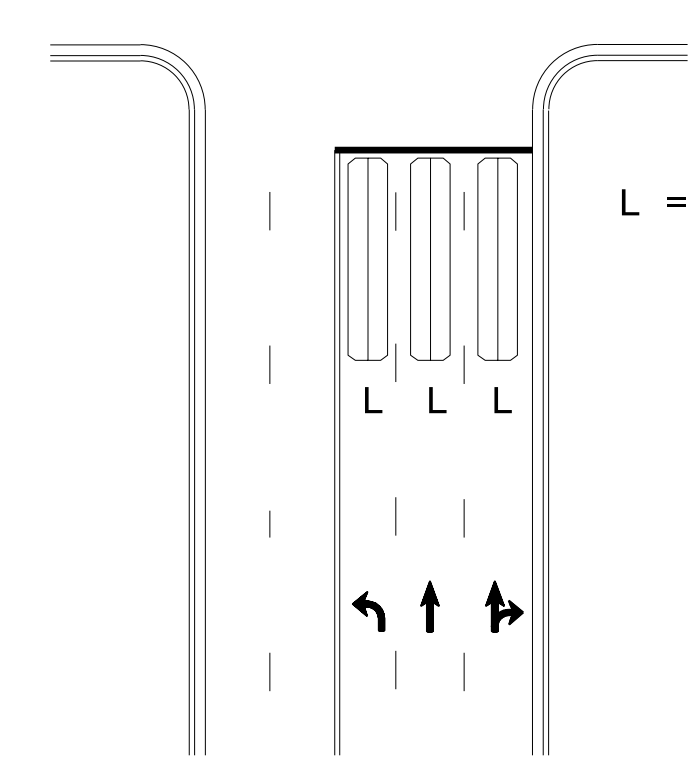

L = 6ft X 40ft
 Quadrupole loop
 Wired to separate
 detectors/channels

Presence Loop Placement at Stop Lines

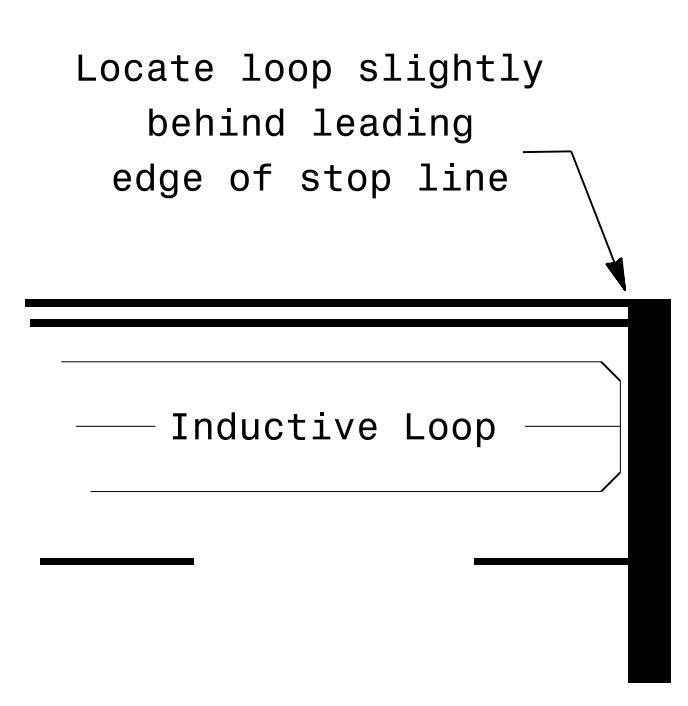

Locate loop slightly
 behind leading
 edge of stop line

Note:
 Loop may be located in advance
 of stop line under any of the
 following conditions:
 1) stop line is greater than 15'
 from edge of intersecting
 roadway
 2) loop detects a permissive or
 protected/permissive left turn
 3) for an exclusive right turn
 lane

Recommended Number of Turns

Single 6' X 6' loop
 (when wired separately):

Length of Lead-in ft	Number of Turns
< 250	3
250-375	4
375-525	5
> 525	6

Quadrupole loops: Use 2-4-2 turns
 6' X 15' Loops:
 Lead-in < 150', use 2 turns
 Lead-in > 150', use 3 turns

Prepared In the Offices of:
 TRANSPORTATION MOBILITY AND SAFETY SOLUTIONS, INC.
 SIGNAL DESIGN SECTION
 750 N. Greenfield Pkwy, Garner, NC 27529

Typical Signal Loop Locations

PLAN DATE: January 2015	REVIEWED BY: JPG
PREPARED BY: PLA	REVIEWED BY:
REVISIONS	INIT. DATE

SCALE: N/A

SEAL
 NORTH CAROLINA
 PROFESSIONAL ENGINEER
 PAMELA L. ALEXANDER
 23489

DocuSigned by:
 P. Alexander
 1/30/2015 10:44:44 AM
 SIG. INVENTORY NO.

3D:\4146-2015_12\319
 S:\4146\4146-TS\SIGNAL\SIGNAL Design Section\Eastern Region\loop\loop\ypj\ca\2015.dgn
 paalexander