

**This electronic collection of documents is provided
for the convenience of the user
and is Not a Certified Document –**

**The documents contained herein were originally issued
and sealed by the individuals whose names and license
numbers appear on each page, on the dates appearing
with their signature on that page.**

**This file or an individual page
shall not be considered a certified document.**

STATE OF NORTH CAROLINA
DIVISION OF HIGHWAYS

TRANSPORTATION MANAGEMENT PLAN

FORSYTH COUNTY

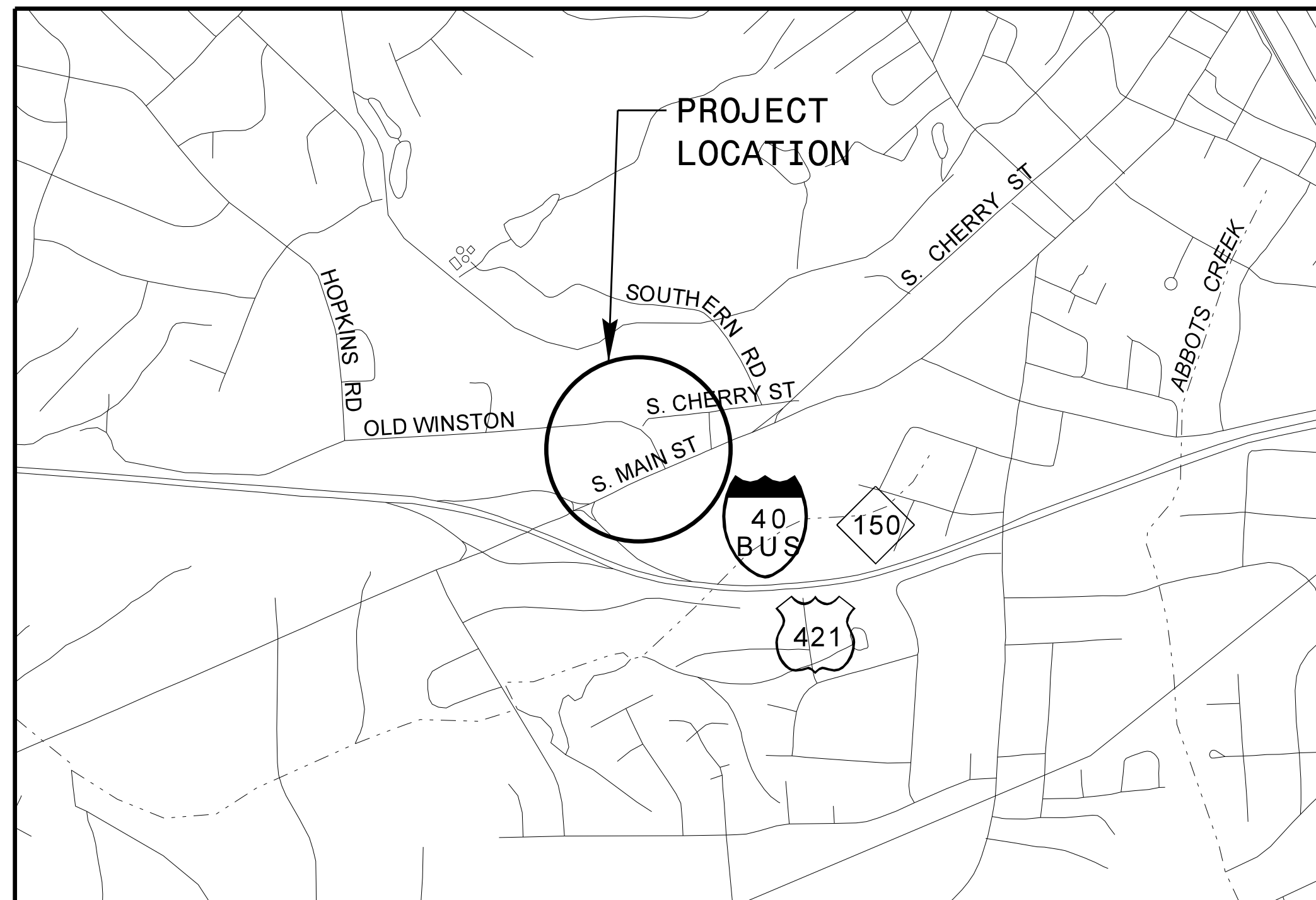
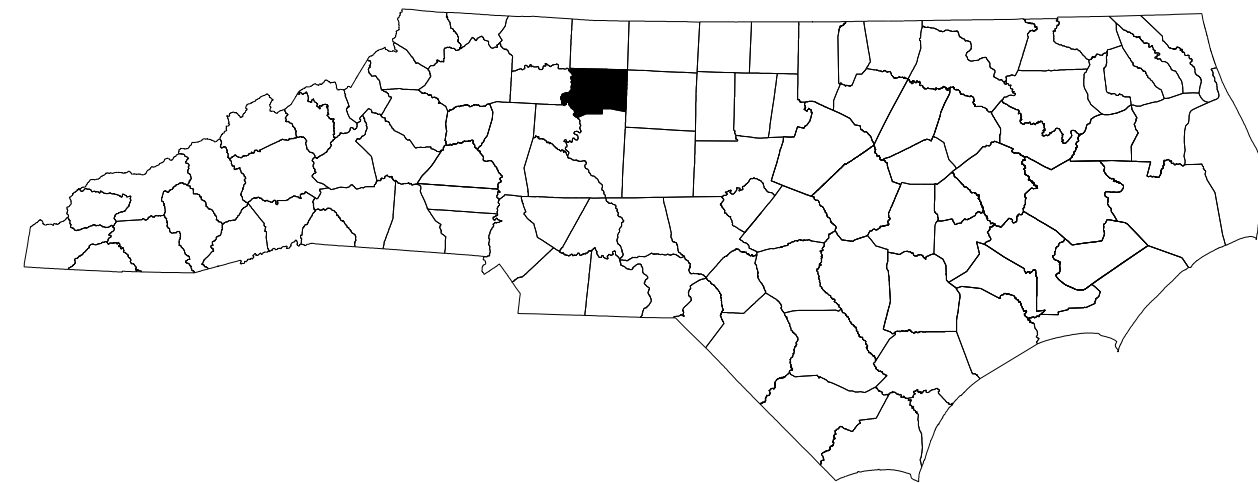

VICINITY MAP



INDEX OF SHEETS

<u>SHEET NO.</u>	<u>TITLE</u>
TMP-1	TITLE SHEET, VICINITY MAP AND INDEX OF SHEETS
TMP-1A	LIST OF APPLICABLE ROADWAY STANDARD DRAWINGS, AND LEGEND
TMP-1B	TRANSPORTATION OPERATIONS PLAN: (MANAGEMENT STRATEGIES, GENERAL NOTES AND LOCAL NOTES)
TMP-2	DETOUR ROUTE
TMP-3	TEMPORARY TRAFFIC CONTROL PHASING
TMP-4 THRU TMP-6	TEMPORARY TRAFFIC CONTROL PHASE I DETAIL
TMP-7 THRU TMP-9	TEMPORARY TRAFFIC CONTROL PHASE II DETAIL
TMP-10 THRU TMP-12	TEMPORARY TRAFFIC CONTROL PHASE III DETAIL
SD-1	SPECIAL SIGN DESIGN

SHEET NO.
TMP-1

TIP PROJECT: W-5510

Kimley»Horn

MATT WEST, P.E. *TRAFFIC CONTROL PROJECT ENGINEER*

DAVID SHINBARA, E.I. *TRAFFIC CONTROL PROJECT DESIGN ENGINEER*

**DOCUMENT NOT CONSIDERED FINAL
UNLESS ALL SIGNATURES COMPLETED**



WORK ZONE SAFETY & MOBILITY
"from the MOUNTAINS to the COAST"

N.C.D.O.T. WORK ZONE TRAFFIC CONTROL
1561 MAIL SERVICE CENTER (MSC) RALEIGH, NC 27699-1561
750 N. GREENFIELD PARKWAY, GARNER, NC 27529 (DELIVERY)
PHONE: (919) 773-2800 FAX: (919) 771-2745

J. S. BOURNE, P.E. *STATE TRAFFIC MANAGEMENT ENGINEER*
DAVID BISSETTE, P.E. *TRAFFIC CONTROL PROJECT ENGINEER*
MIKE STEELMAN *TRAFFIC CONTROL PROJECT DESIGN ENGINEER*
ALLEN HAYES, E.I. *TRAFFIC CONTROL DESIGN ENGINEER*

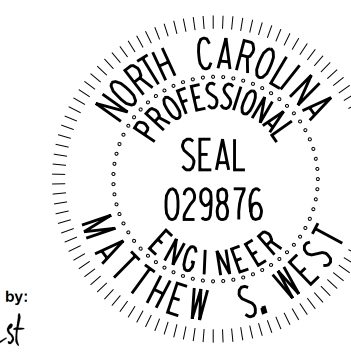
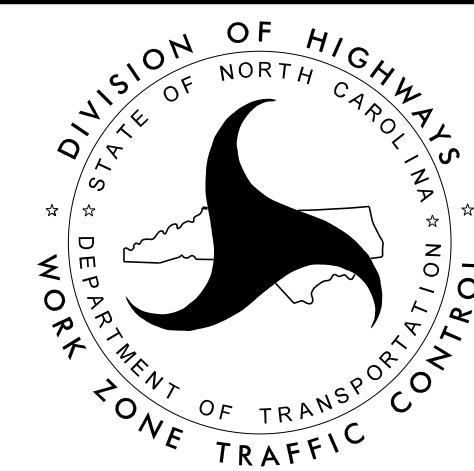

DocuSigned by:
Matt West
8C71A1D0726B426

1/4/2016

APPROVED: _____
DATE: _____

SEAL

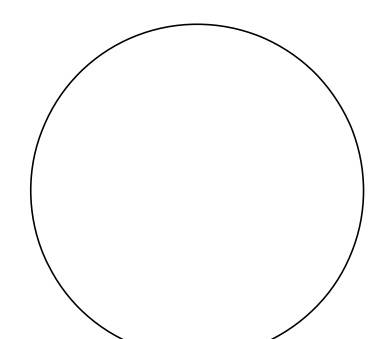

ROADWAY STANDARD DRAWINGS

THE FOLLOWING ROADWAY STANDARDS AS SHOWN IN "ROADWAY STANDARD DRAWINGS" - PROJECT SERVICES UNIT - N.C. DEPARTMENT OF TRANSPORTATION - RALEIGH, N.C., DATED JANUARY 2012 ARE APPLICABLE TO THIS PROJECT AND BY REFERENCE HEREBY ARE CONSIDERED A PART OF THESE PLANS:

STD. NO.	TITLE
1101.01	WORK ZONE ADVANCE WARNING SIGNS
1101.02	TEMPORARY LANE CLOSURES
1101.03	TEMPORARY ROAD CLOSURES
1101.04	TEMPORARY SHOULDER CLOSURES
1101.05	WORK ZONE VEHICLE ACCESSES
1101.06	WARNING SIGNS FOR BLASTING ZONES
1101.11	TRAFFIC CONTROL DESIGN TABLES
1110.01	STATIONARY WORK ZONE SIGNS
1110.02	PORTABLE WORK ZONE SIGNS
1115.01	FLASHING ARROW BOARDS
1130.01	DRUM
1135.01	CONES
1145.01	BARRICADES
1150.01	FLAGGING DEVICES
1160.01	TEMPORARY CRASH CUSHION
1165.01	WORK VEHICLE LIGHTING SYSTEMS AND TMA DELINEATION
1170.01	POSITIVE PROTECTION
1180.01	SKINNY-DRUM
1205.01	PAVEMENT MARKINGS - LINE TYPES AND OFFSETS
1205.02	PAVEMENT MARKINGS - TWO-LANE AND MULTI-LANE ROADWAYS
1205.03	PAVEMENT MARKINGS - EXITS AND ENTRANCE RAMP
1205.04	PAVEMENT MARKINGS - INTERSECTIONS
1205.05	PAVEMENT MARKINGS - TURN LANES
1205.06	PAVEMENT MARKINGS - LANE DROPS
1205.07	PAVEMENT MARKINGS - PEDESTRIAN CROSSWALKS
1205.08	PAVEMENT MARKINGS - SYMBOLS AND WORD MESSAGES
1205.09	PAVEMENT MARKINGS - PAINTED ISLANDS
1205.10	PAVEMENT MARKINGS - SCHOOL AREAS
1205.11	PAVEMENT MARKINGS - RAILROAD CROSSINGS
1205.12	PAVEMENT MARKINGS - BRIDGES
1205.13	PAVEMENT MARKINGS - LANE REDUCTIONS
1250.01	RAISED PAVEMENT MARKERS - INSTALLATION SPACING
1251.01	RAISED PAVEMENT MARKERS - PERMANENT AND TEMPORARY
1261.01	GUARDRAIL AND BARRIER DELINEATORS - INSTALLATION SPACING
1261.02	GUARDRAIL AND BARRIER DELINEATORS - TYPES AND MOUNTING
1262.01	GUARDRAIL END DELINEATION
1264.01	OBJECT MARKERS - TYPES
1264.02	OBJECT MARKERS - INSTALLATION

LEGEND

GENERAL

- DIRECTION OF TRAFFIC FLOW
- DIRECTION OF PEDESTRIAN TRAFFIC FLOW
- EXIST. PVMT.
- NORTH ARROW
- PROPOSED PVMT.
- TEMP. SHORING (LOCATION PURPOSES ONLY)

- WORK AREA
- REMOVAL
- USER DEFINED (IF NEEDED)
- USER DEFINED (IF NEEDED)

SIGNALS

- EXISTING
- PROPOSED
- TEMPORARY

PAVEMENT MARKINGS

- EXISTING LINES
- TEMPORARY LINES

TEMPORARY PAVEMENT MARKING

PAVEMENT MARKING LINES

- PA - PAINT (4" WHITE, 2X) EDGELINE
- PB - PAINT (4" YELLOW, 2X) EDGELINE
- PC - PAINT (4" WHITE, 2X) 4" X 10' SKIP
- PD - PAINT (4" WHITE, 2X) 4" x 2' MINISKIP
- PE - PAINT (4" WHITE, 2X) SOLID LANE LINE
- PF - PAINT (4" YELLOW, 2X) 4" X 10' SKIP
- PG - PAINT (4" YELLOW, 2X) 4" x 2' MINISKIP
- PH - PAINT (4" YELLOW, 2X) SINGLE CENTER LINE
- PI - PAINT (4" YELLOW, 2X) DOUBLE CENTER LINE
- PR - PAINT (8" WHITE, 2X) GORELINE
- PS - PAINT (8" WHITE, 2X) DIAGONAL
- PV - PAINT (8" YELLOW, 2X) DIAGONAL
- PX - PAINT (8" WHITE, 2X) CROSSWALK
- P2 - PAINT (24" WHITE, 2X) STOP BAR

PAVEMENT MARKING SYMBOLS

- QA - PAINT 2X (LEFT TURN ARROW)
- QB - PAINT 2X (RIGHT TURN ARROW)
- QC - PAINT 2X (STRAIGHT ARROW)
- QD - PAINT 2X (COMBINATION STRAIGHT & LEFT TURN ARROW)
- QE - PAINT 2X (COMBINATION STRAIGHT & RIGHT TURN ARROW)
- QG - PAINT 2X (COMBINATION STRAIGHT, RIGHT, & LEFT TURN ARROW)
- QI - PAINT 2X (ALPHANUMERIC CHARACTER)
- QN - PAINT 2X (24" YIELD LINE TRIANGLE)
- QW - PAINT 2X (FISH-HOOK RIGHT TURN AND STRAIGHT ARROW)
- QB - PAINT 2X (FISH-HOOK WITH CIRCLE LEFT TURN AND STRAIGHT ARROW)

TRAFFIC CONTROL DEVICES

- BARRICADE (TYPE III)
- CONE
- DRUM SKINNY DRUM TUBULAR MARKER
- TEMPORARY CRASH CUSHION
- FLASHING ARROW BOARD
- FLAGGER
- LAW ENFORCEMENT
- TRUCK MOUNTED ATTENUATOR (TMA)
- CHANGEABLE MESSAGE SIGN

TEMPORARY SIGNING

- PORTABLE SIGN
- STATIONARY SIGN
- STATIONARY OR PORTABLE SIGN

PAVEMENT MARKERS

- CRYSTAL/CRYSTAL
- CRYSTAL/RED
- YELLOW/YELLOW

PAVEMENT MARKING SYMBOLS

- PAVEMENT MARKING SYMBOLS

\$\$\$\$\$SYTIME\$\$\$\$\$
 \$\$\$DDON\$\$\$\$\$
 \$\$\$USERNAME\$\$\$\$\$

DOCUMENT NOT CONSIDERED FINAL
UNLESS ALL SIGNATURES COMPLETED

APPROVED: _____ DATE: _____

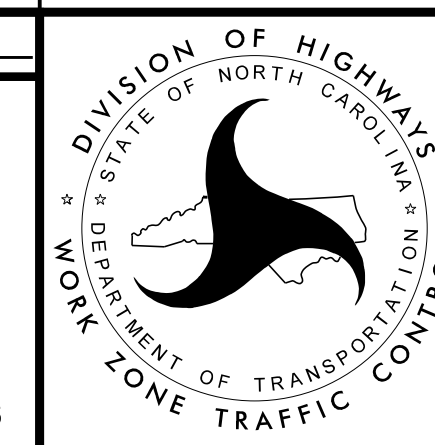
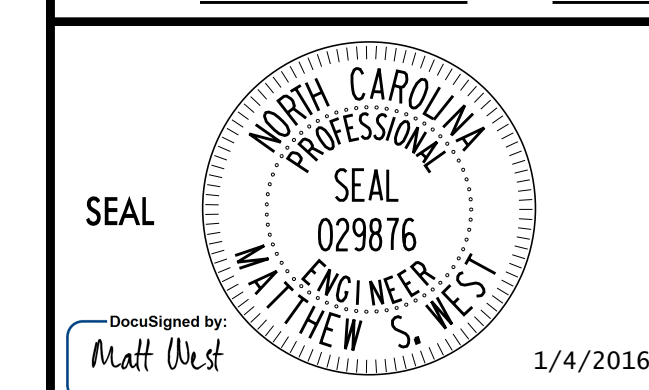

ROADWAY STANDARD
DRAWINGS & LEGEND

MANAGEMENT STRATEGIES

THE PROPOSED ROUNDABOUT WILL BE CONSTRUCTED PRIMARILY AWAY FROM TRAFFIC. PROPOSED IMPROVEMENTS ALONG S MAIN STREET, S CHERRY STREET, AND OLD WINSTON ROAD WILL BE CONSTRUCTED IN 3 PHASES USING TEMPORARY TRAFFIC PATTERNS MAINTAINED BY TEMPORARY PAVEMENT MARKINGS, TEMPORARY SIGNALS, AND SIGNING. TEMPORARY LANE AND SHOULDER CLOSURES, AND TEMPORARY 1 LANE 2 WAY FLAGGER OPERATIONS WILL BE USED AS NECESSARY OUTSIDE OF PEAK HOUR TRAFFIC TIMES TO COMPLETE CONSTRUCTION.

GENERAL NOTES

CHANGES MAY BE REQUIRED WHEN PHYSICAL DIMENSIONS IN THE DETAIL DRAWINGS, STANDARD DETAILS, AND ROADWAY DETAILS ARE NOT ATTAINABLE TO MEET FIELD CONDITIONS OR RESULT IN DUPLICATE OR UNDESIRED OVERLAPPING OF DEVICES. MODIFICATION MAY INCLUDE: MOVING, SUPPLEMENTING, COVERING, OR REMOVAL OF DEVICES AS DIRECTED BY THE ENGINEER.

THE FOLLOWING GENERAL NOTES APPLY AT ALL TIMES FOR THE DURATION OF THE CONSTRUCTION PROJECT EXCEPT WHEN OTHERWISE NOTED IN THE PLAN OR DIRECTED BY THE ENGINEER.

TIME RESTRICTIONS

A) DO NOT CLOSE OR NARROW TRAVEL LANES AS FOLLOWS:

ROAD NAME	DAY AND TIME RESTRICTIONS
S MAIN STREET S CHERRY STREET OLD WINSTON ROAD	6:00 AM - 9:00 AM AND 4:00 PM - 7:00 PM MONDAY THRU FRIDAY

B) DO NOT CLOSE OR NARROW TRAVEL LANES DURING HOLIDAYS AND SPECIAL EVENTS AS FOLLOWS:

ROAD NAME
S MAIN STREET S CHERRY STREET OLD WINSTON ROAD

HOLIDAY

- FOR ANY UNEXPECTED OCCURRENCE THAT CREATES UNUSUALLY HIGH TRAFFIC VOLUMES, AS DIRECTED BY THE ENGINEER.
- FOR NEW YEAR'S, BETWEEN THE HOURS OF 6:00 A.M. DECEMBER 31st TO 7:00 P.M. JANUARY 2ND. IF NEW YEAR'S DAY IS ON A FRIDAY, SATURDAY, SUNDAY, OR MONDAY THEN UNTIL 7:00 P.M. THE FOLLOWING TUESDAY.
- FOR EASTER, BETWEEN THE HOURS OF 6:00 A.M. THURSDAY AND 7:00 P.M. MONDAY.
- FOR MEMORIAL DAY, BETWEEN THE HOURS OF 6:00 A.M. FRIDAY TO 7:00 P.M. TUESDAY.
- FOR INDEPENDENCE DAY, BETWEEN THE HOURS OF 6:00 A.M. THE DAY BEFORE INDEPENDENCE DAY AND 7:00 P.M. THE DAY AFTER INDEPENDENCE DAY.

IF INDEPENDENCE DAY IS ON A FRIDAY, SATURDAY, SUNDAY OR MONDAY THEN BETWEEN THE HOURS OF 6:00 A.M. THE THURSDAY BEFORE INDEPENDENCE DAY AND 7:00 P.M. THE TUESDAY AFTER INDEPENDENCE DAY.
- FOR LABOR DAY, BETWEEN THE HOURS OF 6:00 A.M. FRIDAY AND 7:00 P.M. TUESDAY.
- FOR THANKSGIVING DAY, BETWEEN THE HOURS OF 6:00 A.M. TUESDAY TO 7:00 P.M. MONDAY.
- FOR CHRISTMAS, BETWEEN THE HOURS OF 6:00 A.M. THE FRIDAY BEFORE THE WEEK OF CHRISTMAS DAY AND 7:00 P.M. THE FOLLOWING TUESDAY AFTER THE WEEK OF CHRISTMAS.

C) DO NOT STOP TRAFFIC AS FOLLOWS:

ROAD NAME	DAY AND TIME RESTRICTIONS	DURATION AND OPERATION
S MAIN STREET S CHERRY STREET OLD WINSTON ROAD	6:00 AM - 9:00 AM AND 4:00 PM - 7:00 PM MONDAY THRU FRIDAY	15 MINUTES FOR PAVEMENT MARKING TIE-INS

D) DO NOT CONDUCT ANY HAULING OPERATIONS AGAINST THE FLOW OF TRAFFIC OF AN OPEN TRAVELWAY UNLESS THE HAULING OPERATION IS PROTECTED BY BARRIER OR GUARDRAIL OR AS DIRECTED BY THE ENGINEER.

LANE AND SHOULDER CLOSURE REQUIREMENTS

E) REMOVE LANE CLOSURE DEVICES FROM THE LANE WHEN WORK IS NOT BEING PERFORMED BEHIND THE LANE CLOSURE OR WHEN A LANE CLOSURE IS NO LONGER NEEDED OR AS DIRECTED BY THE ENGINEER.

F) WHEN PERSONNEL AND/OR EQUIPMENT ARE WORKING WITHIN 15 FT OF AN OPEN TRAVEL LANE, CLOSE THE NEAREST OPEN SHOULDER USING ROADWAY STANDARD DRAWING NO. 1101.04 UNLESS THE WORK AREA IS PROTECTED BY BARRIER OR GUARDRAIL OR A LANE CLOSURE IS INSTALLED.

G) WHEN PERSONNEL AND/OR EQUIPMENT ARE WORKING ON THE SHOULDER ADJACENT TO AN UNDIVIDED FACILITY AND WITHIN 5 FT OF AN OPEN TRAVEL LANE, CLOSE THE NEAREST OPEN TRAVEL LANE USING ROADWAY STANDARD DRAWING NO. 1101.02 UNLESS THE WORK AREA IS PROTECTED BY BARRIER OR GUARDRAIL.

WHEN PERSONNEL AND/OR EQUIPMENT ARE WORKING ON THE SHOULDER ADJACENT TO A DIVIDED FACILITY AND WITHIN 10 FT OF AN OPEN TRAVEL LANE, CLOSE THE NEAREST OPEN TRAVEL LANE USING ROADWAY STANDARD DRAWING NO. 1101.02 UNLESS THE WORK AREA IS PROTECTED BY BARRIER OR GUARDRAIL.

H) WHEN PERSONNEL AND/OR EQUIPMENT ARE WORKING WITHIN A LANE OF TRAVEL OF AN UNDIVIDED OR DIVIDED FACILITY, CLOSE THE LANE ACCORDING TO THE TRAFFIC CONTROL PLANS, ROADWAY STANDARD DRAWINGS, OR AS DIRECTED BY THE ENGINEER. CONDUCT THE WORK SO THAT ALL PERSONNEL AND/OR EQUIPMENT REMAIN WITHIN THE CLOSED TRAVEL LANE.

I) DO NOT WORK SIMULTANEOUSLY WITHIN 15 FT ON BOTH SIDES OF AN OPEN TRAVELWAY, RAMP, OR LOOP WITHIN THE SAME LOCATION UNLESS PROTECTED WITH GUARDRAIL OR BARRIER.

J) DO NOT INSTALL MORE THAN ONE LANE CLOSURE IN ANY ONE DIRECTION ON ALL STREETS.

PAVEMENT EDGE DROP OFF REQUIREMENTS

K) BACKFILL AT A 6:1 SLOPE UP TO THE EDGE AND ELEVATION OF EXISTING PAVEMENT IN AREAS ADJACENT TO AN OPENED TRAVEL LANE THAT HAS AN EDGE OF PAVEMENT DROP-OFF AS FOLLOWS:

BACKFILL DROP-OFFS THAT EXCEED 2 INCHES ON ROADWAYS WITH POSTED SPEED LIMITS OF 45 MPH OR GREATER.

BACKFILL DROP-OFFS THAT EXCEED 3 INCHES ON ROADWAYS WITH POSTED SPEED LIMITS LESS THAN 45 MPH.

BACKFILL WITH SUITABLE COMPACTED MATERIAL, AS APPROVED BY THE ENGINEER, AT NO EXPENSE TO THE DEPARTMENT.

L) DO NOT EXCEED A DIFFERENCE OF 2 INCHES IN ELEVATION BETWEEN OPEN LANES OF TRAFFIC FOR NOMINAL LIFTS OF 1.5 INCHES. INSTALL ADVANCE WARNING "UNEVEN LANES" SIGNS (W8-11) 100 FT IN ADVANCE AND A MINIMUM OF EVERY HALF MILE THROUGHOUT THE UNEVEN AREA.

TRAFFIC PATTERN ALTERATIONS

M) NOTIFY THE ENGINEER TWENTY ONE (21) CALENDAR DAYS PRIOR TO ANY TRAFFIC PATTERN ALTERATION.

SIGNING

N) INSTALL ADVANCE WORK ZONE WARNING SIGNS WHEN WORK IS WITHIN 40 FT FROM THE EDGE OF TRAVEL LANE AND NO MORE THAN THREE (3) DAYS PRIOR TO THE BEGINNING OF CONSTRUCTION.

O) ENSURE ALL NECESSARY SIGNING IS IN PLACE PRIOR TO ALTERING ANY TRAFFIC PATTERN.

P) INSTALL BLACK ON ORANGE "DIP" SIGNS (W8-2) AND/OR "BUMP" SIGNS (W8-1) 100 FT IN ADVANCE OF THE UNEVEN AREA, OR AS DIRECTED BY THE ENGINEER.

TRAFFIC CONTROL DEVICES

Q) WHEN LANE CLOSURES ARE NOT IN EFFECT SPACE CHANNELIZING DEVICES IN WORK AREAS NO GREATER IN FEET THAN TWICE THE POSTED SPEED LIMIT (MPH) EXCEPT, 10 FT ON-CENTER IN RADII, AND 3 FT OFF THE EDGE OF AN OPEN TRAVELWAY. REFER TO STANDARD SPECIFICATIONS FOR ROADS AND STRUCTURES SECTIONS 1130 (DRUMS), 1135 (CONES) AND 1180 (SKINNY DRUMS) FOR ADDITIONAL REQUIREMENTS.

R) PLACE TYPE III BARRICADES, WITH "ROAD CLOSED" SIGN R11-2 ATTACHED, OF SUFFICIENT LENGTH TO CLOSE ENTIRE ROADWAY.

S) PLACE ADDITIONAL SETS OF THREE CHANNELIZING DEVICES PERPENDICULAR TO THE EDGE OF TRAVELWAY ON 500 FT CENTERS WHEN UNOPENED LANES ARE CLOSED TO TRAFFIC.

PAVEMENT MARKINGS AND MARKERS

T) INSTALL TEMPORARY PAVEMENT MARKINGS ON INTERIM LAYERS OF PAVEMENT AS FOLLOWS:

ROAD NAME	MARKING
ALL	PAINT

U) PLACE ONE APPLICATION OF PAINT FOR TEMPORARY TRAFFIC PATTERNS. PLACE A SECOND APPLICATION OF PAINT SIX (6) MONTHS AFTER THE INITIAL APPLICATION AND EVERY SIX MONTHS AS DIRECTED BY THE ENGINEER.

V) TIE PROPOSED PAVEMENT MARKING LINES TO EXISTING PAVEMENT MARKING LINES.

W) REMOVE/REPLACE ANY CONFLICTING/DAMAGED PAVEMENT MARKINGS AND MARKERS BY THE END OF EACH DAY'S OPERATION.

MISCELLANEOUS

X) LAW ENFORCEMENT MAY BE USED TO MAINTAIN TRAFFIC THROUGH THE WORK AREA AND/OR INTERSECTIONS AS DIRECTED BY THE ENGINEER.

Y) IN THE EVENT A TIE-IN CANNOT BE MADE IN ONE DAY'S TIME, BRING THE TIE-IN AREA TO AN APPROPRIATE ROADWAY ELEVATION AS DETERMINED BY THE ENGINEER. PLACE BLACK ON ORANGE "LOOSE GRAVEL" SIGNS (W8-7) AND BLACK ON ORANGE "PAVEMENT ENDS" SIGNS (W8-3) 100 FT AND 100 FT RESPECTIVELY IN ADVANCE OF THE UNEVEN AREAS. USE DRUMS TO DELINEATE THE EDGE OF ROADWAY ALONG UNPAVED AREAS.

K:\RAL_Roadway\01036245 - Kernersville\TrafficControl\CP\MP\W5510_TMP_TSH.dgn 12/22/2015

DOCUMENT NOT CONSIDERED FINAL
UNLESS ALL SIGNATURES COMPLETED

APPROVED: _____ DATE: _____

SEAL

DocuSigned by:
Matt West

1/4/2016

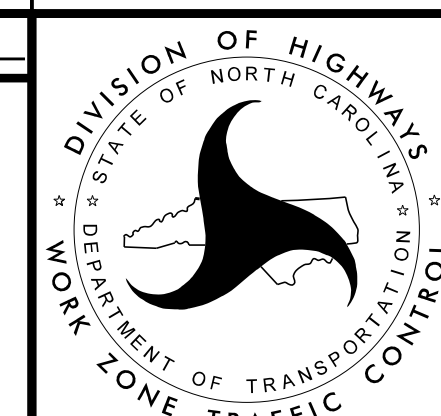

**TRANSPORTATION
OPERATIONS
PLAN**

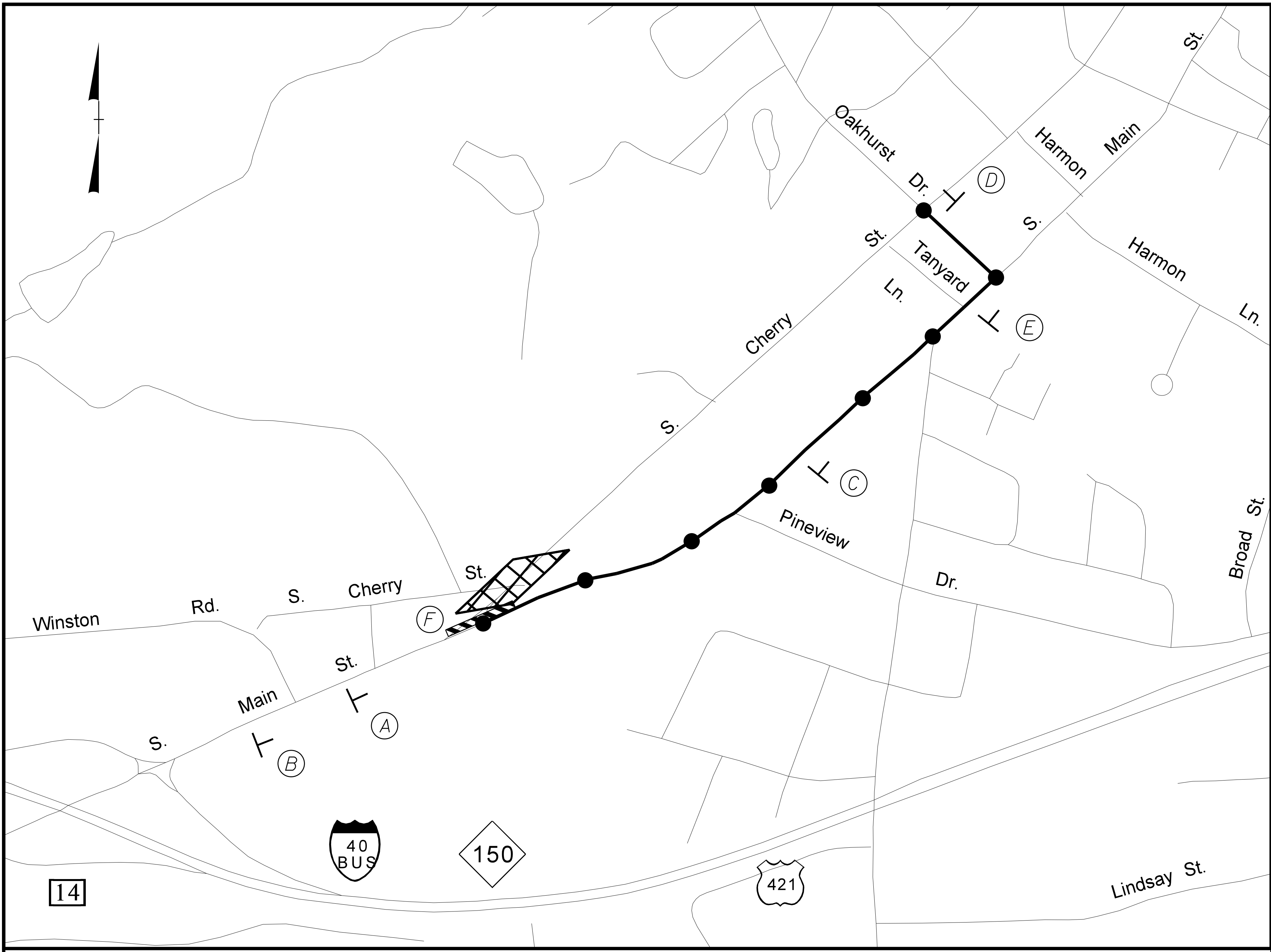

DETOUR ROUTE FOR NORTHBOUND CHERRY STREET CLOSURE

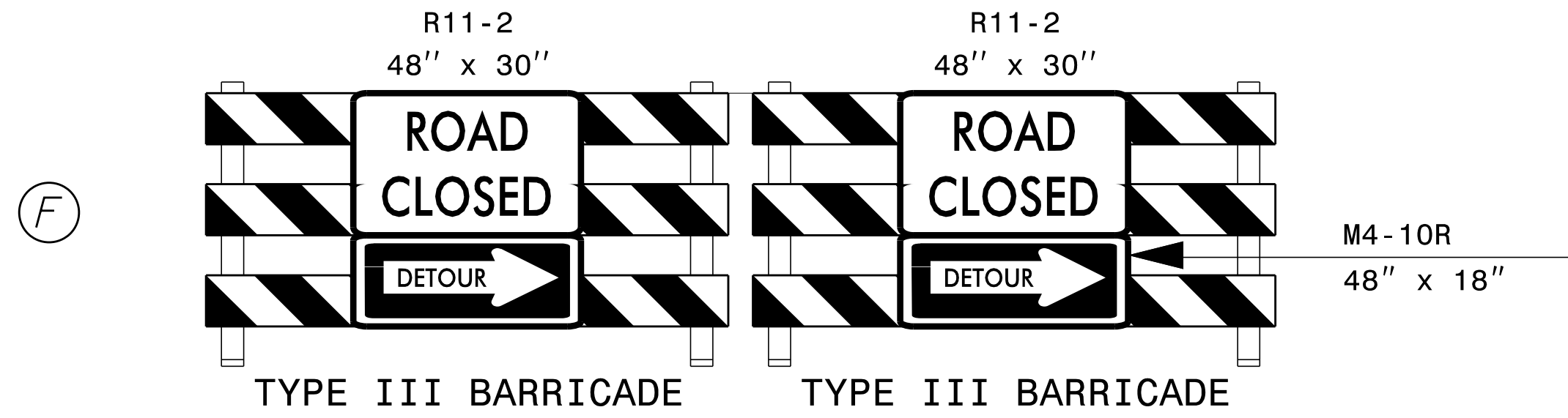
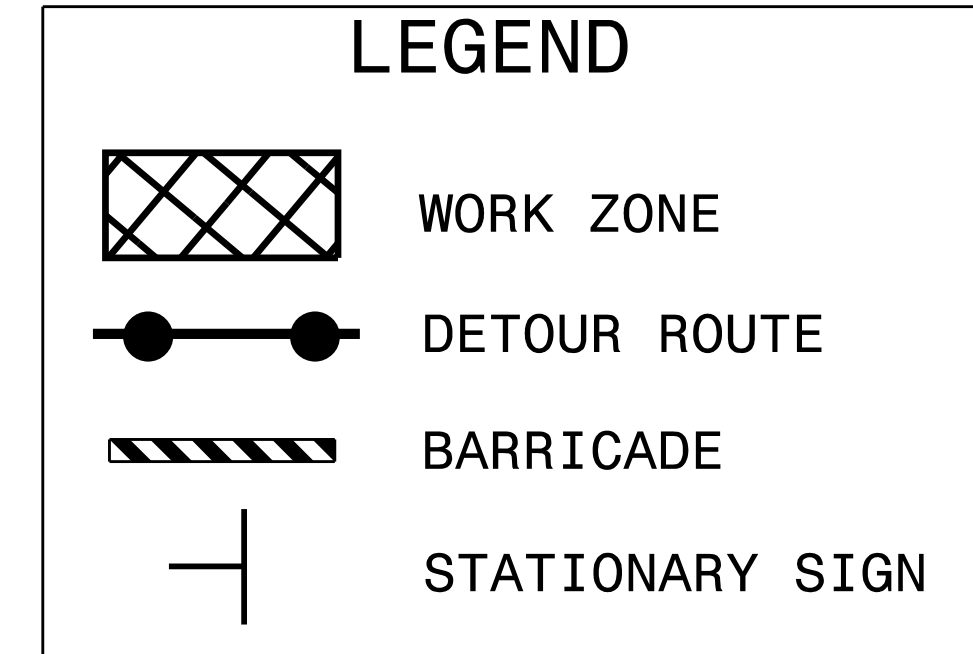
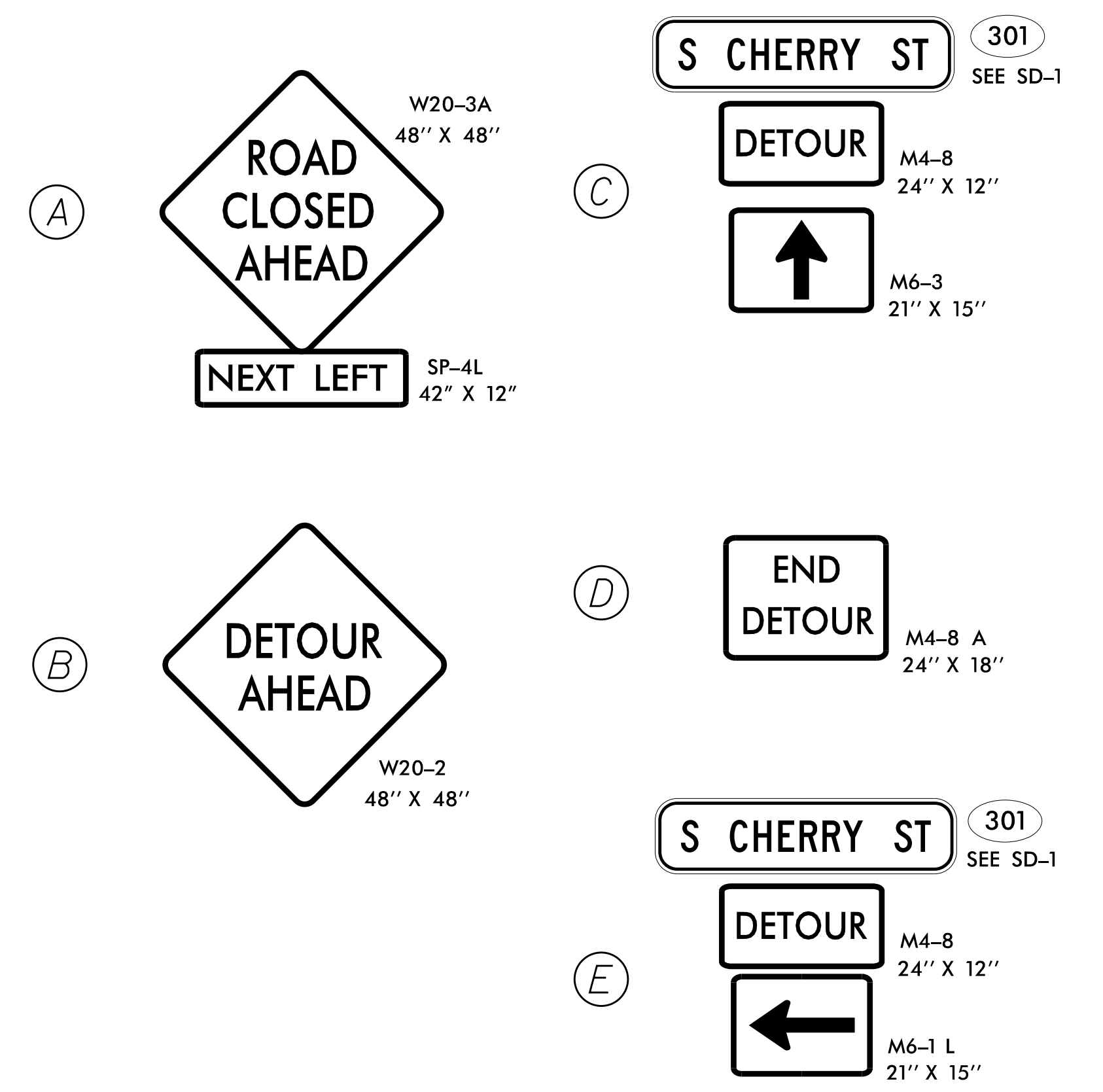

DOCUMENT NOT CONSIDERED FINAL
UNLESS ALL SIGNATURES COMPLETED

APPROVED: _____ DATE: _____

SEAL

DocuSigned by:
Matt West
ACF1A1D0798425

NORTH CAROLINA PROFESSIONAL SEAL
029876
ENGINEER
MATTHEW S. WEST

3/15/2016

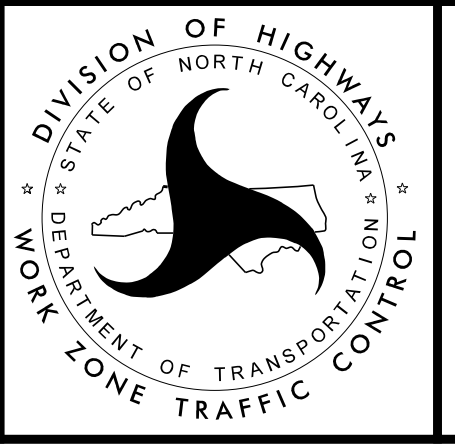

Kimley»Horn

**TRAFFIC CONTROL
DETOUR SHEET**

K:\RAL_Roadway\01036245 - Kernersville\TrafficControl\CPNTMP\W5510_TMP_PSH02.dgn 3/14/2016

CONSTRUCTION PHASING

PHASE I

PRIOR TO BEGINNING ANY CONSTRUCTION ACTIVITY, THE CONTRACTOR SHALL INSTALL WORK ZONE ADVANCE WARNING SIGNS AS SHOWN IN THE NCDOT ROADWAY STANDARD DRAWING NO. 1101.01.

WHILE MAINTAINING EXISTING TRAFFIC ON OLD WINSTON RD, -Y3- S CHERRY ST, -Y4- S CHERRY ST, S MAIN ST AND ALL INTERSECTING ROADWAYS AND DRIVEWAYS, USING NCDOT ROADWAY STANDARD DRAWING NO. 1101.02 FOR TEMPORARY LANE CLOSURES AND RETURNING TRAFFIC TO THE PATTERNS SHOWN ON SHEETS TMP-4 THRU TMP-6 AT THE END OF THE DAY, THE CONTRACTOR SHALL:

STEP 1

INSTALL ALL TRAFFIC CONTROL DEVICES AT THE -Y3- S CHERRY ST/-Y4- S CHERRY ST INTERSECTION AS SHOWN ON SHEET TMP-6.

USING TEMPORARY LANE CLOSURES, WIDEN -Y3- S CHERRY ST AND CONSTRUCT NEW DRIVE AS SHOWN ON SHEET TMP-6 IN ORDER TO MAINTAIN 2 WAY TRAFFIC FOR SUBSEQUENT WORK.

USING TEMPORARY LANE CLOSURES, REMOVE EXISTING CONCRETE ISLAND AND PATCH PAVEMENT ON -Y2- OLD WINSTON RD FROM STA 14+90 TO STA 16+02 IN ORDER TO MAINTAIN THE PHASE 1, STEP 2 TEMPORARY TRAFFIC PATTERN.

STEP 2 (COMPLETE OPERATIONS IN A SINGLE WORK PERIOD)

REMOVE TRAFFIC CONTROL DEVICES ASSOCIATED WITH STEP 1.

USING TEMPORARY LANE CLOSURES, FLAGGERS, AND LAW ENFORCEMENT TO DIRECT TRAFFIC AT INTERSECTION AS NEEDED, REMOVE ALL CONFLICTING PAVEMENT MARKINGS, PLACE TEMPORARY PAVEMENT MARKINGS ALONG -Y2- OLD WINSTON RD AS SHOWN ON SHEETS TMP-4 AND TMP-5, AND SHIFT TRAFFIC ONTO NEW PATTERN.

INSTALL ALL TRAFFIC CONTROL DEVICES ALONG -Y2- OLD WINSTON RD, -Y3- S CHERRY ST, -Y4- S CHERRY ST, AND S MAIN ST AS SHOWN ON SHEETS TMP-4 AND TMP-5.

STEP 3

USING TEMPORARY LANE CLOSURES AS NEEDED, CONSTRUCT PROPOSED IMPROVEMENTS UP TO BUT NOT INCLUDING THE FINAL LAYER OF ASPHALT ALONG -Y1- OLD WINSTON RD, -Y3- S CHERRY ST, AND -L- S MAIN ST AS SHOWN ON SHEETS TMP-4 AND TMP-5.

AWAY FROM TRAFFIC, CONSTRUCT NEW ROUNDABOUT AND NEW -Y1- OLD WINSTON RD

COMPLETE PAVEMENT WEDGING ON -Y1- OLD WINSTON RD FROM STA 15+50 TO 17+80 (APPROX) USING TEMPORARY LANE CLOSURES AND 1 LANE, 2 WAY FLAGGER OPERATIONS.

PHASE II

WHILE MAINTAINING EXISTING TRAFFIC ON -Y1- OLD WINSTON RD, -Y3- S CHERRY ST, -Y4- S CHERRY ST, -L- S MAIN ST AND ALL INTERSECTING ROADWAYS AND DRIVEWAYS, USING NCDOT ROADWAY STANDARD DRAWING NO. 1101.02 FOR TEMPORARY LANE CLOSURES AND RETURNING TRAFFIC TO THE PATTERNS SHOWN ON SHEETS TMP-7 THRU TMP-9 AT THE END OF THE DAY, THE CONTRACTOR SHALL:

STEP 1

REMOVE ALL PHASE 1 TRAFFIC CONTROL DEVICES.

USING TEMPORARY LANE CLOSURES, REMOVE EXISTING CONCRETE ISLAND AND PATCH PAVEMENT ON -L- MAIN STREET FROM STA 19+92 TO STA 21+44 AS SHOWN ON SHEET TMP-8.

INSTALL TEMPORARY TRAFFIC SIGNAL AT -L- S MAIN ST/-Y1- OLD WINSTON RD INTERSECTION. COVER SIGNAL HEADS AND DO NOT ACTIVATE.

STEP 2 (COMPLETE OPERATIONS IN A SINGLE WORK PERIOD)

USING TEMPORARY LANE CLOSURES, FLAGGERS, AND LAW ENFORCEMENT TO DIRECT TRAFFIC AT INTERSECTION AS NEEDED, REMOVE ALL CONFLICTING PAVEMENT MARKINGS, PLACE TEMPORARY PAVEMENT MARKINGS ALONG -Y1- OLD WINSTON RD AND -L- S MAIN ST AS SHOWN ON SHEETS TMP-7 THRU TMP-9, ACTIVATE TEMPORARY SIGNALS AND SHIFT TRAFFIC ONTO NEW PATTERN.

INSTALL ALL TRAFFIC CONTROL DEVICES ALONG -Y1- OLD WINSTON RD, -Y4- S CHERRY ST, AND -L- S MAIN ST AS SHOWN ON SHEETS TMP-7 THRU TMP-9.

STEP 3

USING TEMPORARY LANE CLOSURES AS NEEDED, CONSTRUCT PROPOSED IMPROVEMENTS UP TO BUT NOT INCLUDING THE FINAL LAYER OF ASPHALT ALONG -Y2- OLD WINSTON RD, -Y4- S CHERRY ST, AND -L- S MAIN ST AS SHOWN ON SHEETS TMP-7 THRU TMP-9.

COMPLETE WORK ALONG -Y4- S CHERRY ST SHOWN ON SHEET TMP-9 USING TEMPORARY LANE CLOSURES AND 1 LANE, 2 WAY FLAGGER OPERATIONS.

STEP 4

**INTERMEDIATE CONTRACT TIME
COMPLETE NORTHBOUND CHERRY ST INTERSECTION WORK USING A TEMPORARY CLOSURE OF NORTHBOUND -Y4- S CHERRY ST. CONTRACTOR MAY IMPLEMENT THE CLOSURE FOR A MAXIMUM OF 3 CONSECUTIVE DAYS. REFER TO TMP-2 FOR OFFSITE DETOUR ROUTE. REFER TO PROJECT SPECIFICATIONS FOR LIQUIDATED DAMAGES.**

PHASE III

WHILE MAINTAINING EXISTING TRAFFIC ON -Y1- OLD WINSTON RD, -Y3- S CHERRY ST, -Y4- S CHERRY ST, -L- S MAIN ST AND ALL INTERSECTING ROADWAYS AND DRIVEWAYS, USING NCDOT ROADWAY STANDARD DRAWING NO. 1101.02 FOR TEMPORARY LANE CLOSURES AND RETURNING TRAFFIC TO THE PATTERNS SHOWN ON SHEETS TMP-10 THRU TMP-12 AT THE END OF THE DAY, THE CONTRACTOR SHALL:

STEP 1

REMOVE ALL PHASE 2 TRAFFIC CONTROL DEVICES.

INSTALL FINAL TRAFFIC SIGNAL AT -L- S MAIN ST/-Y1- OLD WINSTON RD INTERSECTION. COVER SIGNAL HEADS AND DO NOT ACTIVATE.

STEP 2 (COMPLETE OPERATIONS IN A SINGLE WORK PERIOD)

USING TEMPORARY LANE CLOSURES, FLAGGERS, AND LAW ENFORCEMENT TO DIRECT TRAFFIC AT INTERSECTION AS NEEDED, REMOVE ALL CONFLICTING PAVEMENT MARKINGS, PLACE TEMPORARY PAVEMENT MARKINGS ALONG -Y1- OLD WINSTON RD, -Y2-, -L- S MAIN ST, -Y3- S CHERRY ST, AND -Y4- S CHERRY ST IN THE FINAL PATTERN AS SHOWN ON SHEETS TMP-10 THRU TMP-12 AND ON THE PAVEMENT MARKING PLANS, ACTIVATE FINAL SIGNALS AND SHIFT TRAFFIC ONTO FINAL PATTERN.

INSTALL ALL TRAFFIC CONTROL DEVICES ALONG -Y1- OLD WINSTON RD, -Y3- S CHERRY ST, -Y4- S CHERRY ST, AND -L- S MAIN ST AS SHOWN ON SHEETS TMP-10 THRU TMP-12.

COMPLETE STEP 2 OPERATIONS IN A SINGLE WORK PERIOD.

STEP 3

USING TEMPORARY LANE CLOSURES, CONSTRUCT PROPOSED MEDIAN IMPROVEMENTS ALONG -Y1- OLD WINSTON RD, -Y2-, -Y4- S CHERRY ST, AND -L- S MAIN ST AS SHOWN ON SHEETS TMP-10 THRU TMP-12.

STEP 4

USING TEMPORARY LANE CLOSURES, FLAGGERS, AND LAW ENFORCEMENT TO DIRECT TRAFFIC AT INTERSECTION AS NEEDED, PLACE FINAL SURFACE COURSE OF PAVEMENT, AND PLACE FINAL PAVEMENT MARKINGS AND MARKERS AS SHOWN IN THE PAVEMENT MARKING PLANS.

OPEN ALL LANES TO TRAFFIC AND REMOVE ALL TRAFFIC CONTROL DEVICES.

K:\RAL_Roadway\01036245 - Kernersville\TrafficControl\TrafficControl\W5510_TMP_TSH.dgn 3/21/2016

DOCUMENT NOT CONSIDERED FINAL UNLESS ALL SIGNATURES COMPLETED	
APPROVED: _____	DATE: _____
	
DocuSigned by: <i>Matthew S. West</i> 3/21/2016	

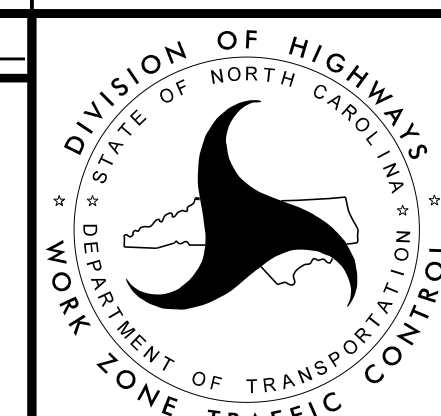

TRANSPORTATION OPERATIONS PLAN

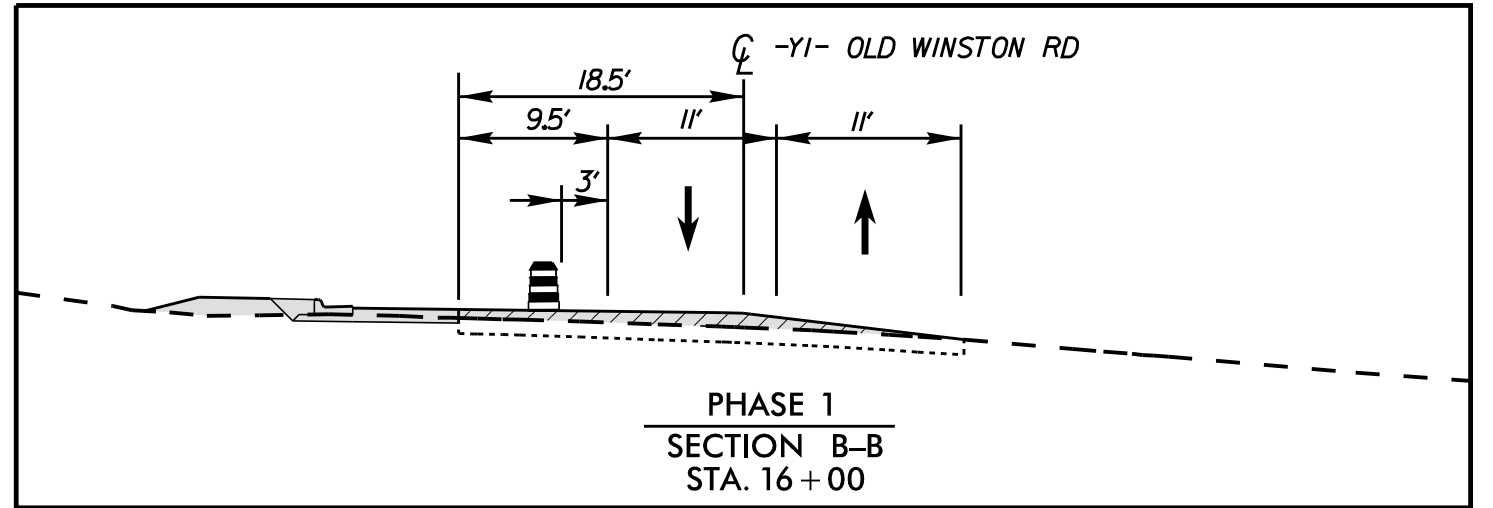

BEGIN CONSTRUCTION
-Y1- POT Sta. 10+20.00

-Y1- STA. 14+00
TIE TO EXIST.
PAVEMENT MARKINGS

COMPLETE WEDGING USING A TEMPORARY
LANE CLOSURE AND ONE LANE, TWO WAY
FLAGGER OPERATIONS

MATCHLINE -Y1- STA 17+50.00 (SHEET TMP-05)

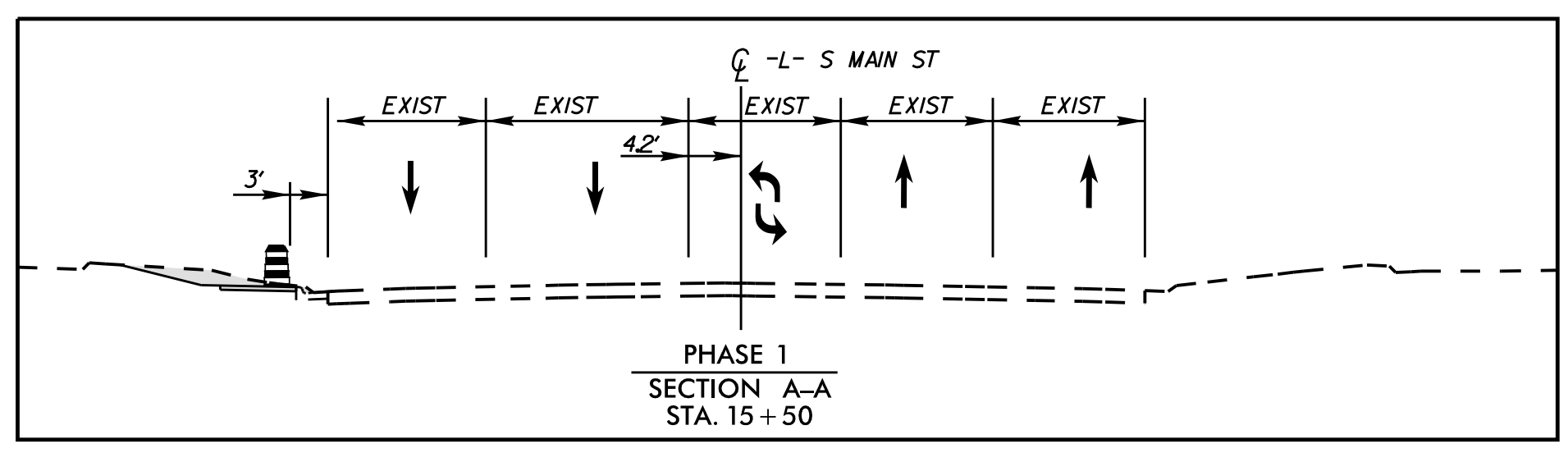
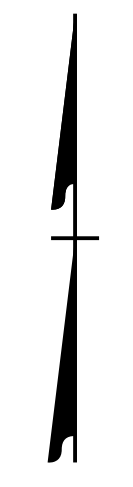
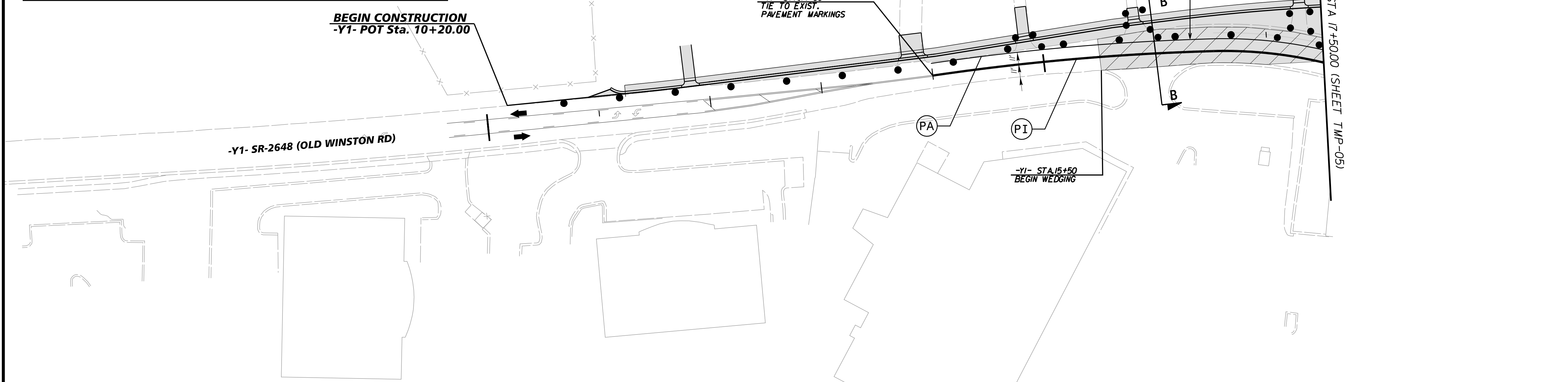

BEGIN CONSTRUCTION
-L- POT Sta. 14+23.00



MATCHLINE -L- STA 17+50.00 (TMP-05 SHEET)

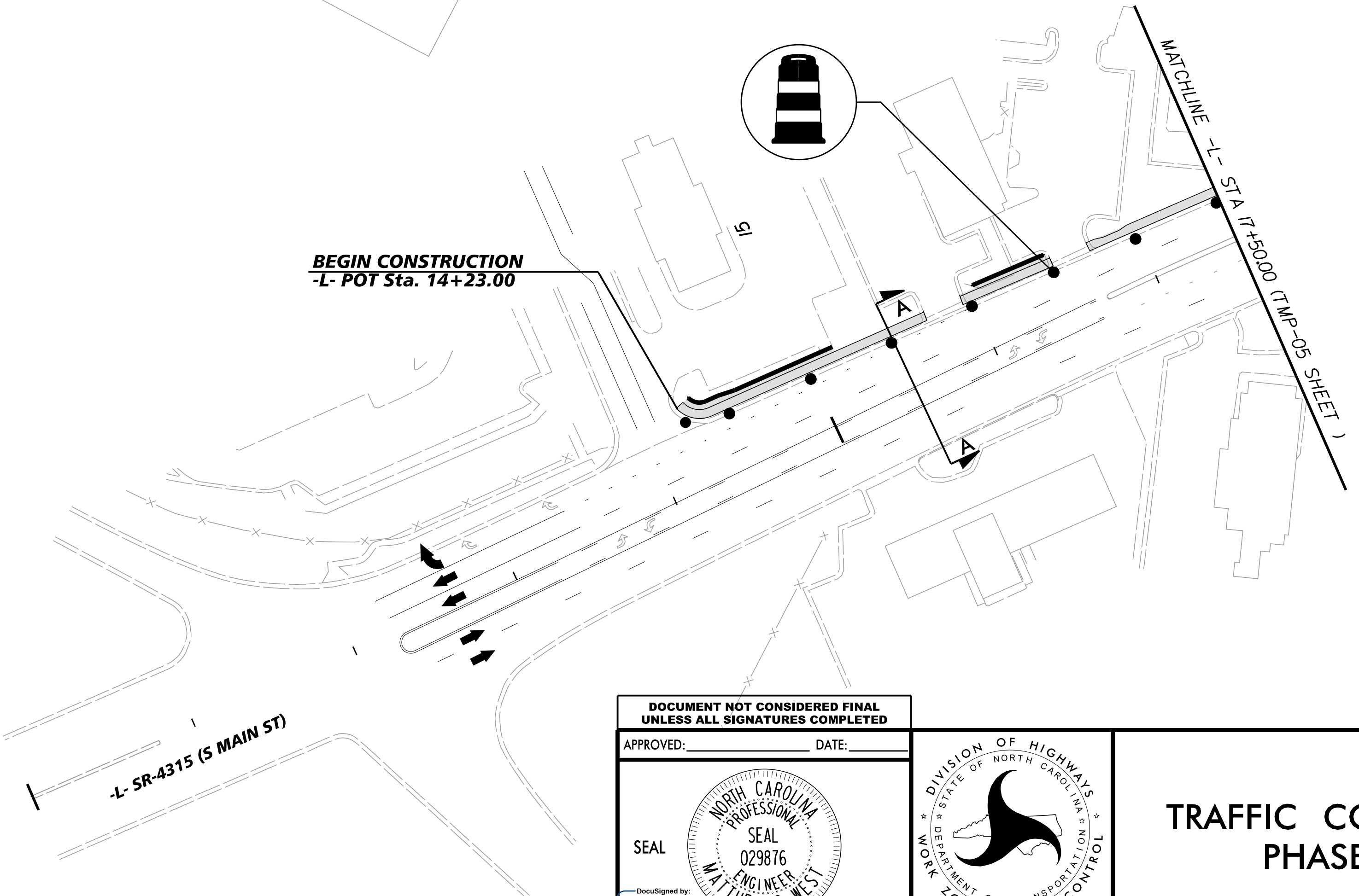

- WORK AREA
- PAVEMENT REMOVAL
- WEDGING

DOCUMENT NOT CONSIDERED FINAL
UNLESS ALL SIGNATURES COMPLETED

APPROVED: _____ DATE: _____

SEAL

North Carolina Professional Seal
029876
ENGINEER
MATTHEW S. WEST

DocuSigned by:
Matt West
3/15/2016

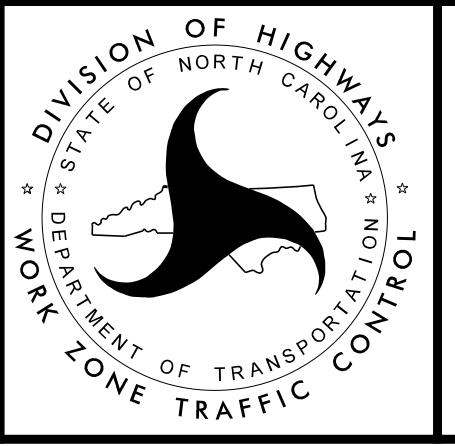

**TRAFFIC CONTROL
PHASE I**

K:\RAL_Roadway\01036245 - Kernersville\TrafficControl\TMP\W5510_TMP_PSH04.dgn 3/14/2016

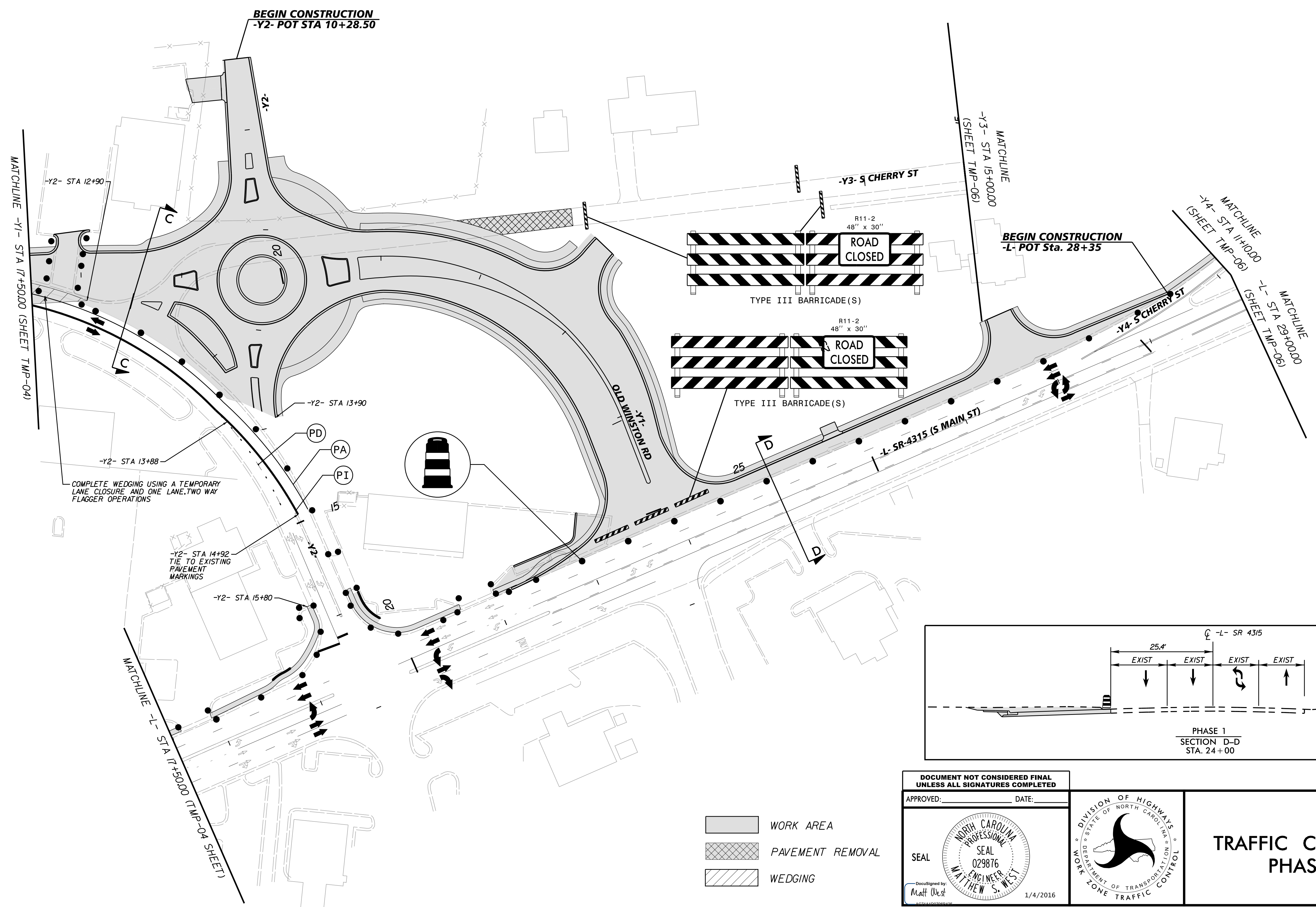
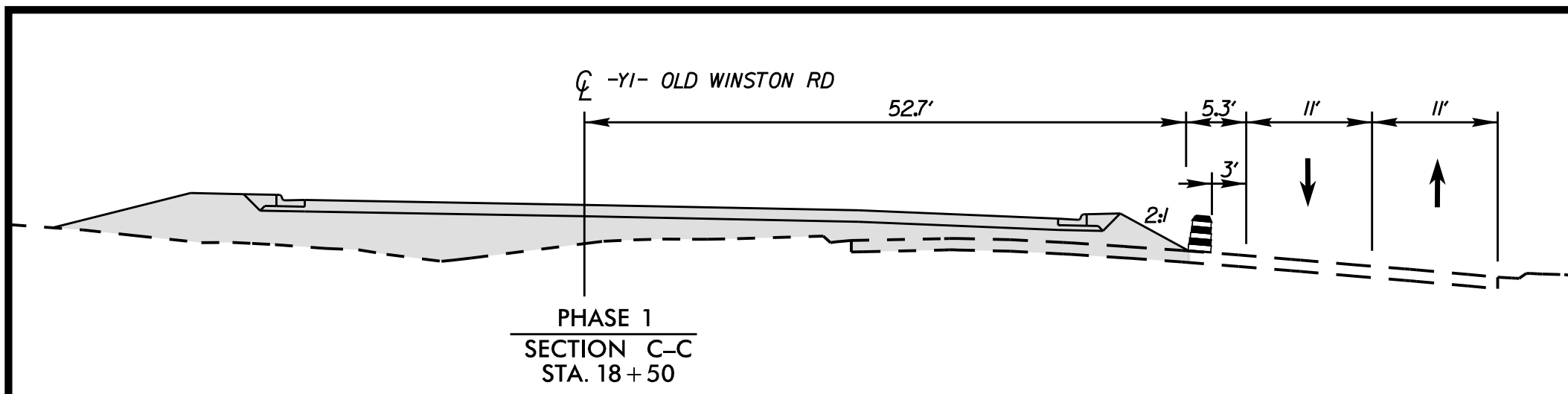
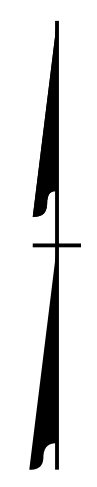

COMPLETE WEDGING USING A TEMPORARY LANE CLOSURE AND ONE LANE, TWO WAY FLAGGER OPERATIONS

-Y2- STA 14+92 TIE TO EXISTING PAVEMENT MARKINGS

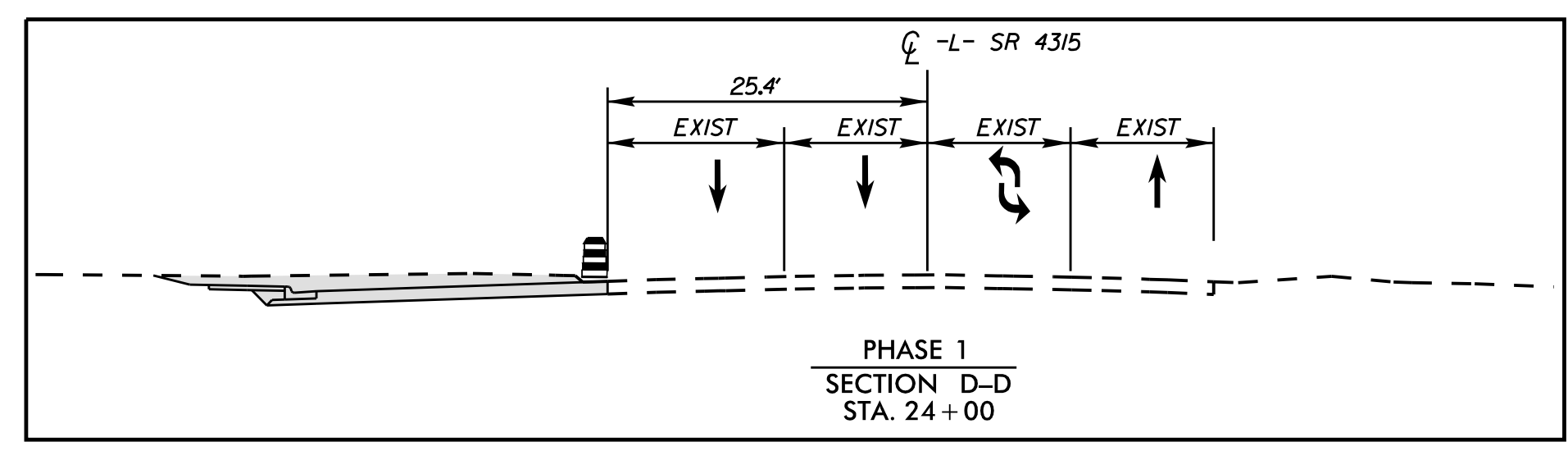

- WORK AREA
- PAVEMENT REMOVAL
- WEDGING

DOCUMENT NOT CONSIDERED FINAL UNLESS ALL SIGNATURES COMPLETED

APPROVED: _____ DATE: _____

SEAL

DocuSigned by: **Matthew S. West** 1/4/2016

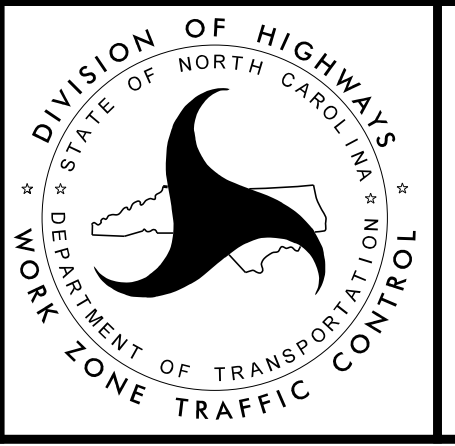

TRAFFIC CONTROL PHASE I

K:\RAL_Roadway\01036245 - Kernersville\TrafficControl\TMP\W5510_TMP_PSH05.dgn 12/22/2015

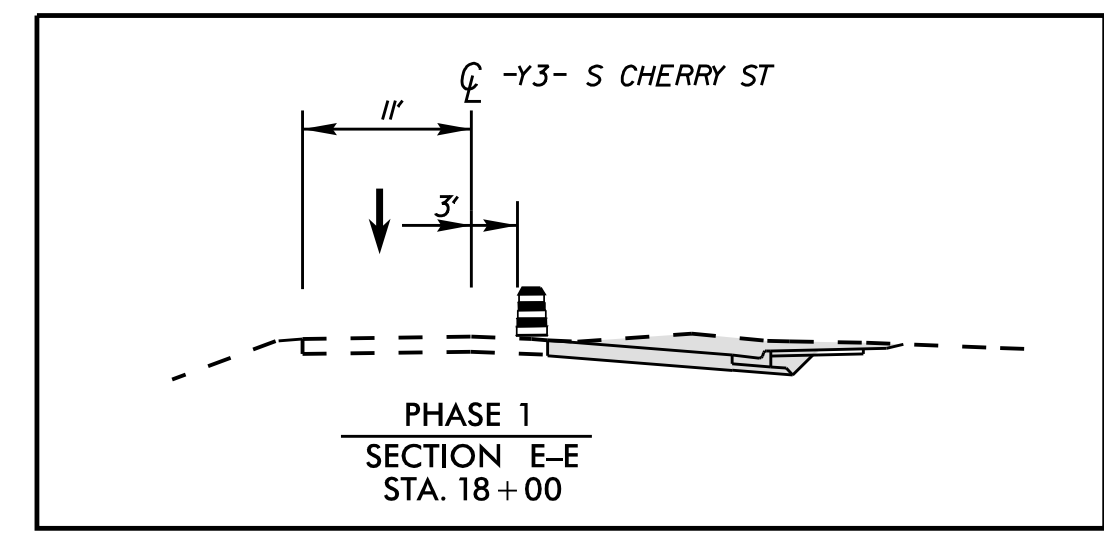

K:\RAL_Roadway\01036245 - Kernersville\TrafficControl\CPNTMP\W5510_TMP_PSH06.dgn
3/14/2016

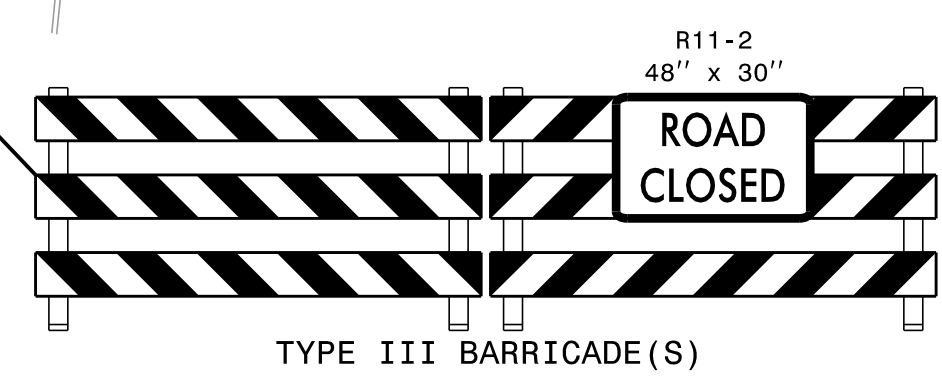
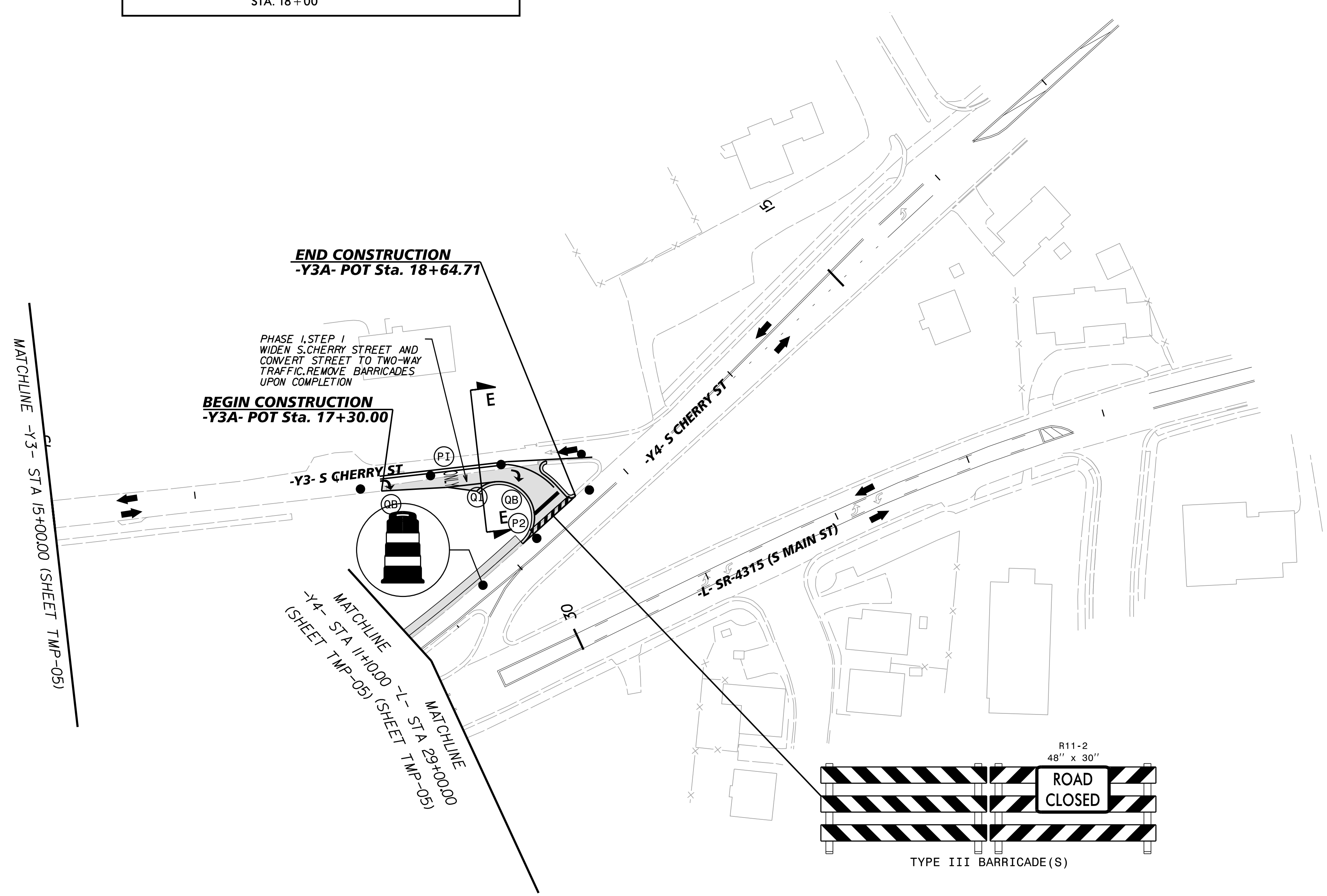

- WORK AREA
- PAVEMENT REMOVAL
- WEDGING

DOCUMENT NOT CONSIDERED FINAL
UNLESS ALL SIGNATURES COMPLETED

APPROVED: _____ DATE: _____

SEAL

DocuSigned by:
Matthew S. West
3/15/2016

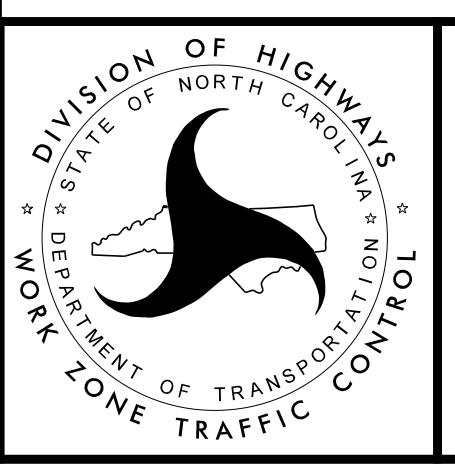

**TRAFFIC CONTROL
PHASE I**



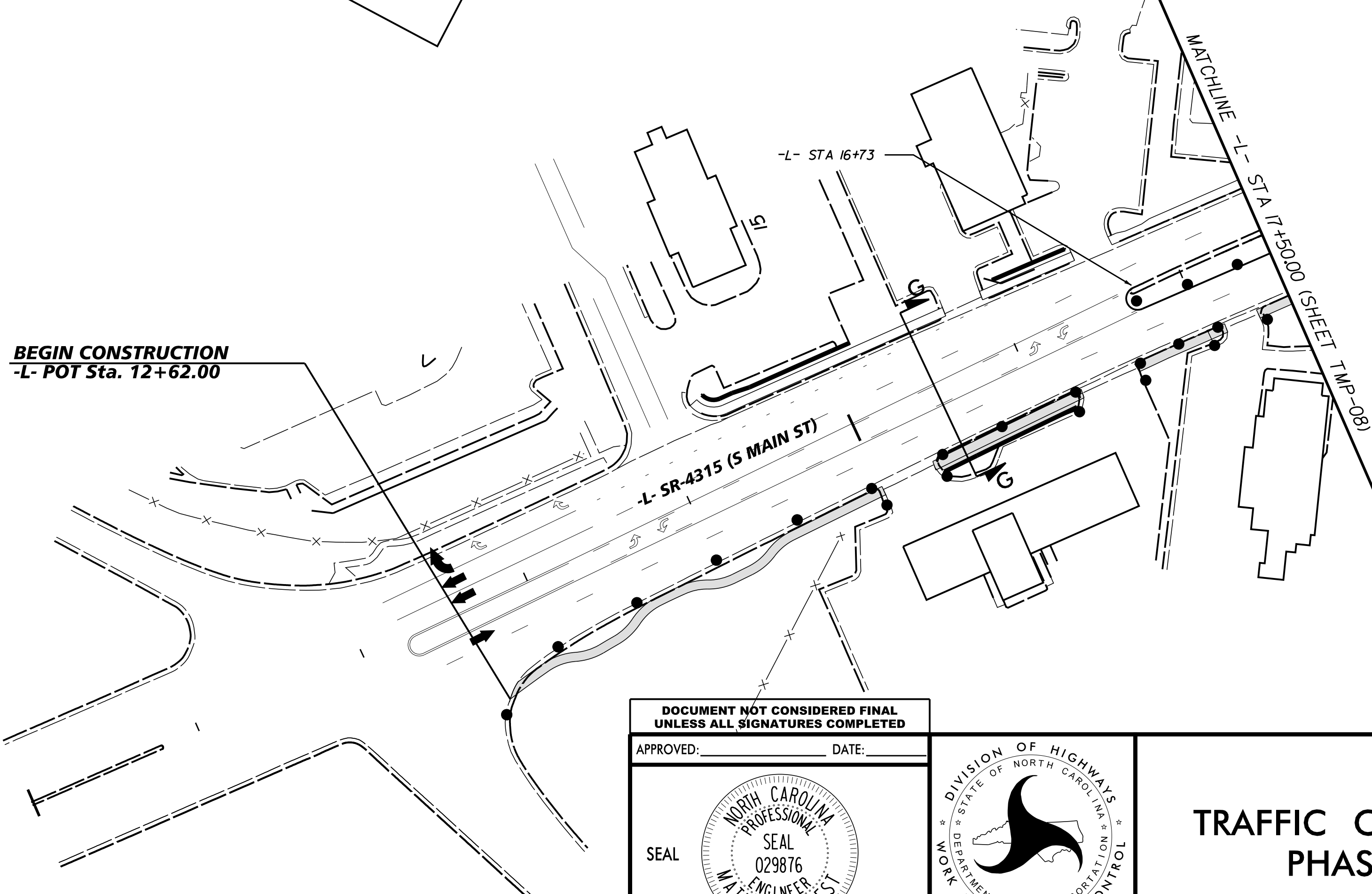
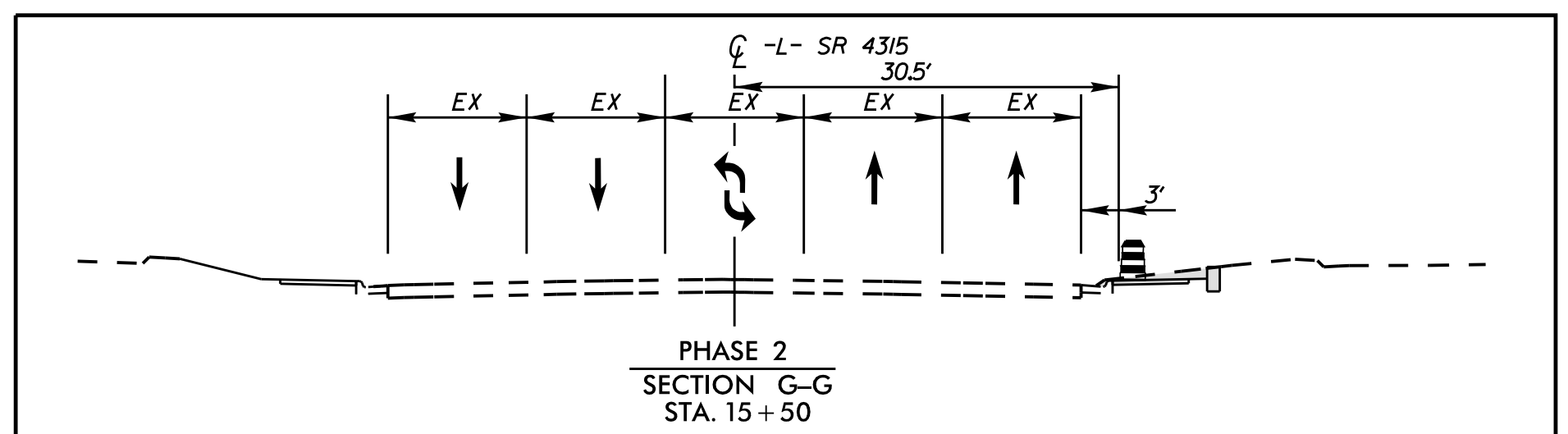
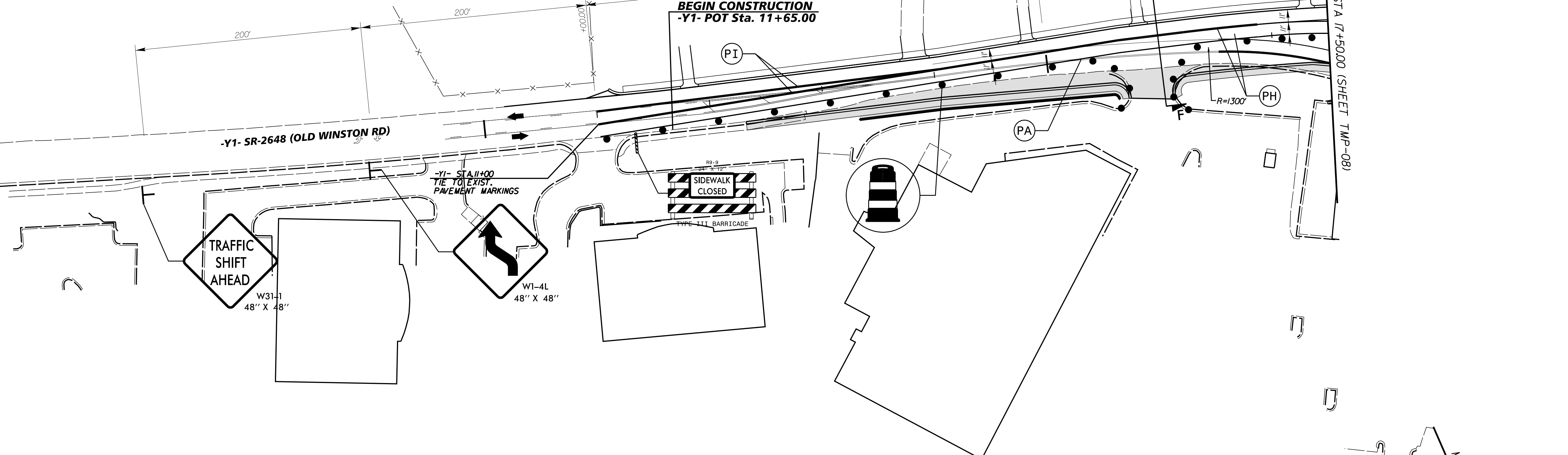
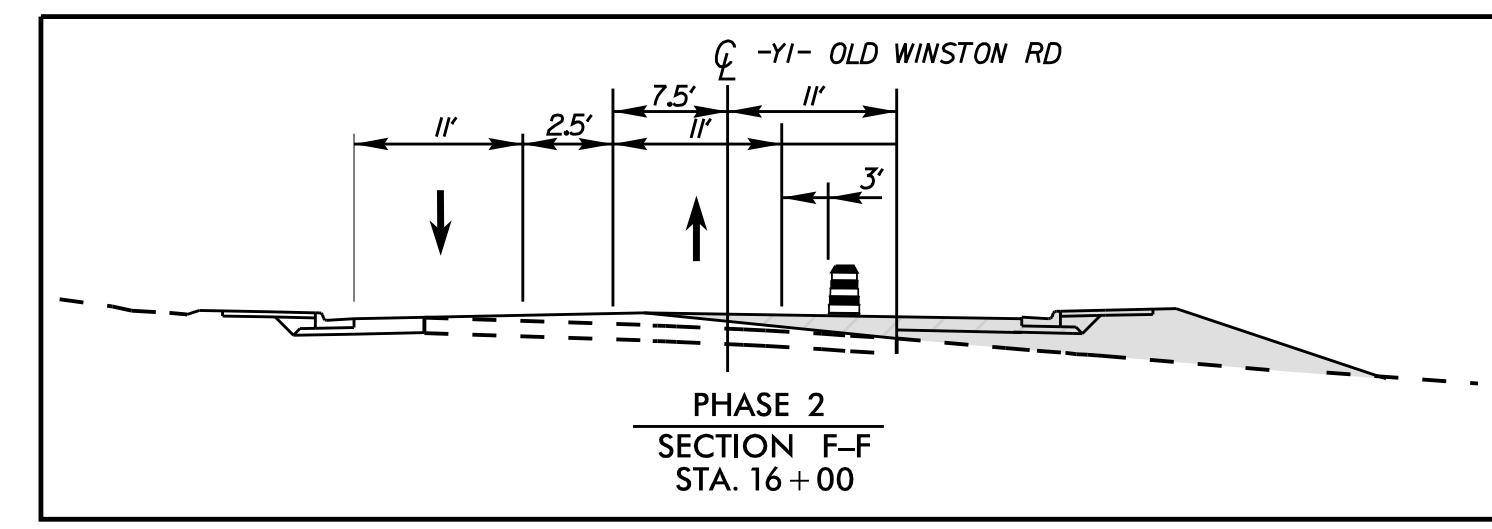

- WORK AREA
- PAVEMENT REMOVAL
- WEDGING

DOCUMENT NOT CONSIDERED FINAL
UNLESS ALL SIGNATURES COMPLETED

APPROVED: _____ DATE: _____

SEAL

DocuSigned by:
Matthew S. West

3/15/2016

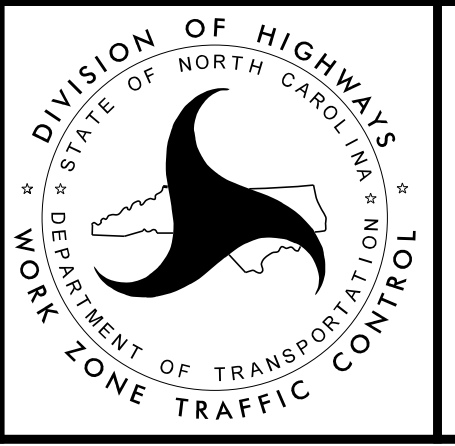

**TRAFFIC CONTROL
PHASE II**

K:\RAL_Roadway\01036245 - Kernersville\TrafficControl\CPNTMP\W5510_TMP_PSHOT.dgn 3/14/2016

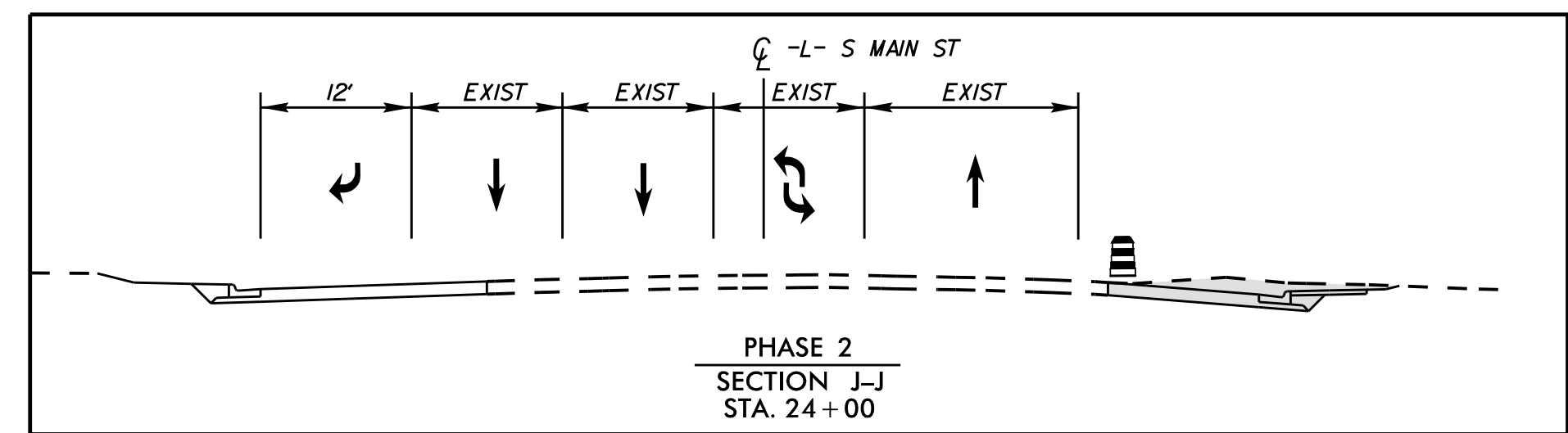
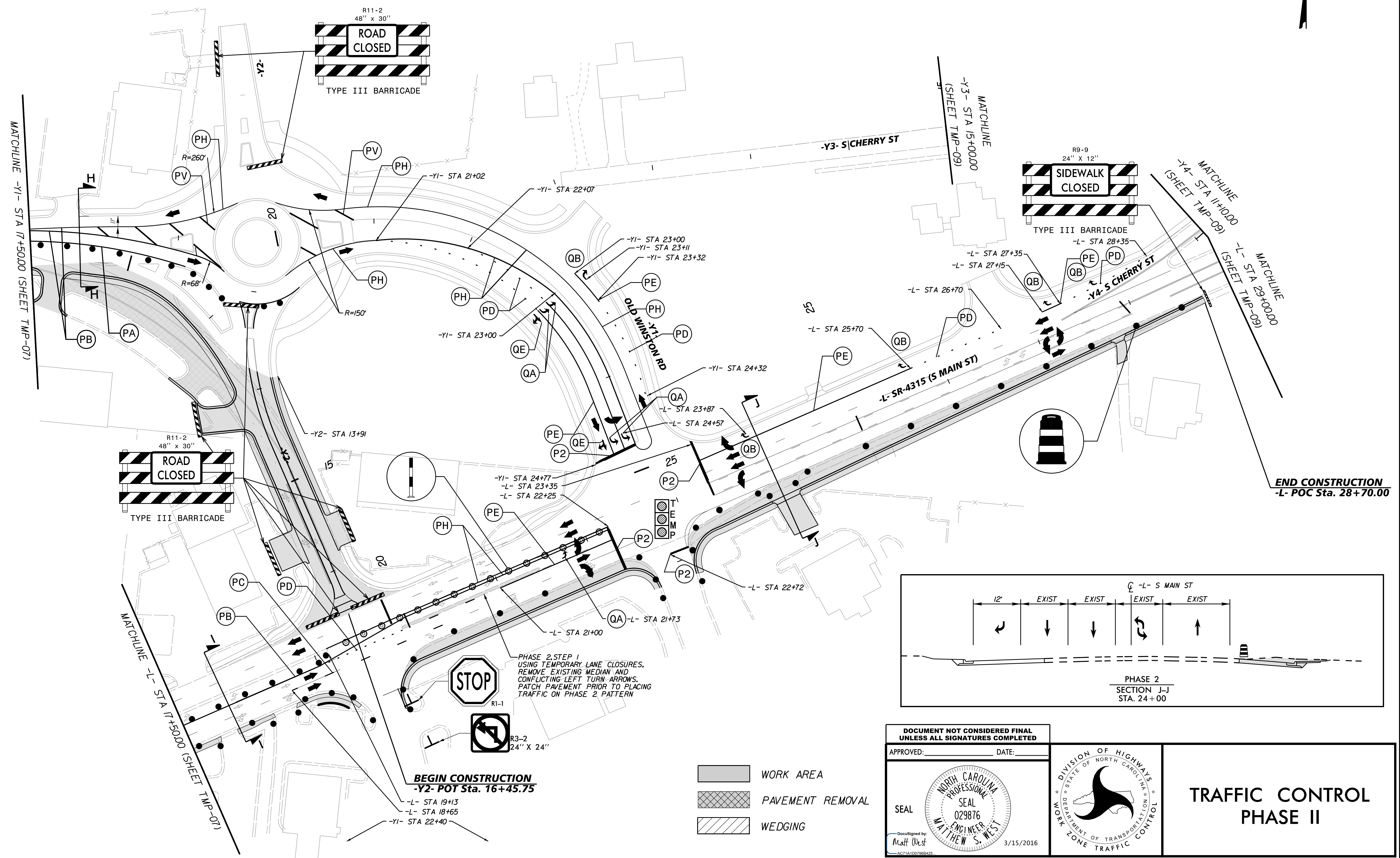
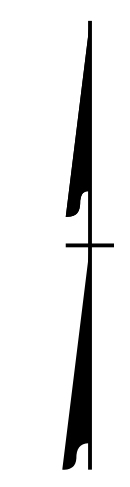
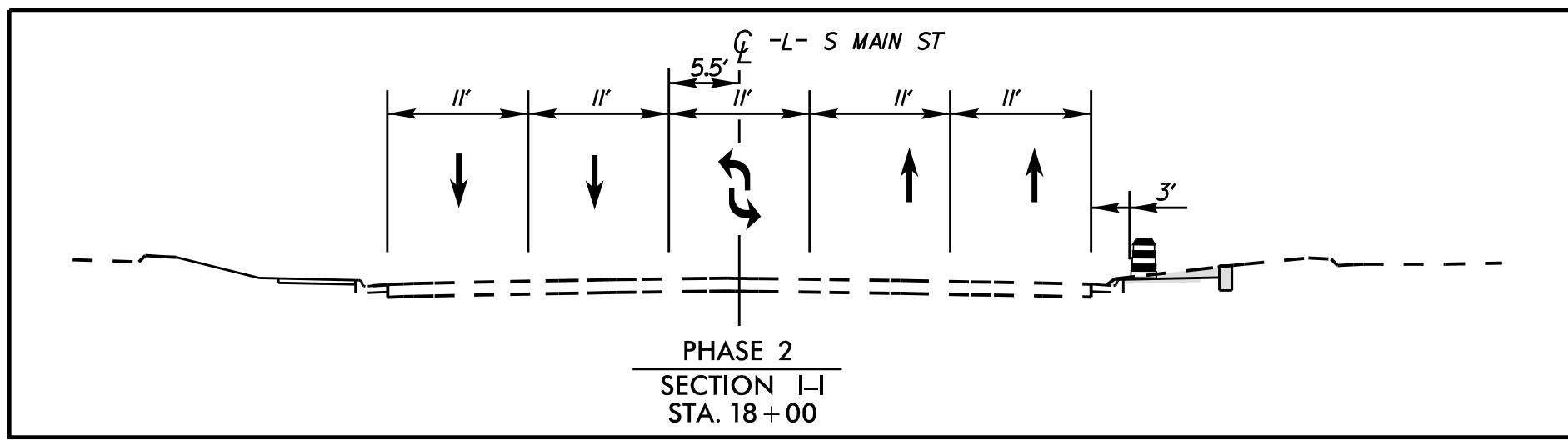
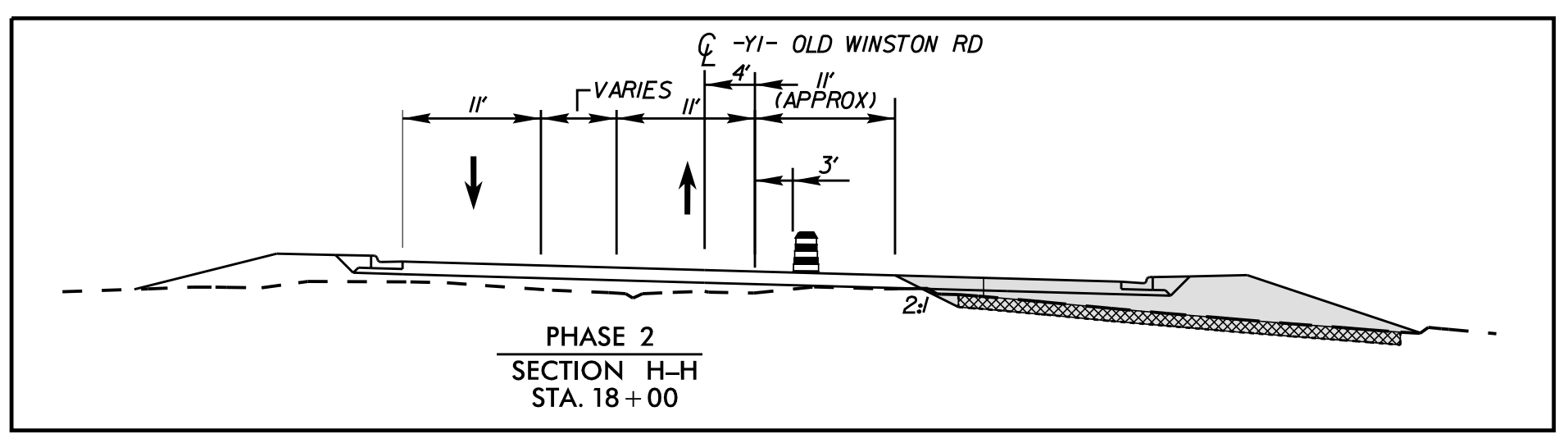

DOCUMENT NOT CONSIDERED FINAL
UNLESS ALL SIGNATURES COMPLETED

APPROVED: _____ DATE: _____

SEAL
 NORTH CAROLINA PROFESSIONAL ENGINEER
 SEAL 029876
 MATTHEW S. WEST
 3/15/2016

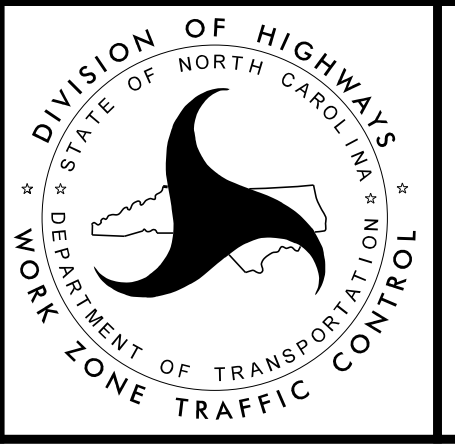

TRAFFIC CONTROL PHASE II

3/14/2016 K:\RAL_Roadway\01036245 - Kernersville\TrafficControl\TMP\W5510_TMP_PSH08.dgn

K:\RAL_Roadway\01036245 - Kernersville\TrafficControl\TCPT\W5510_TMP_PSH09.dgn
12/22/2015

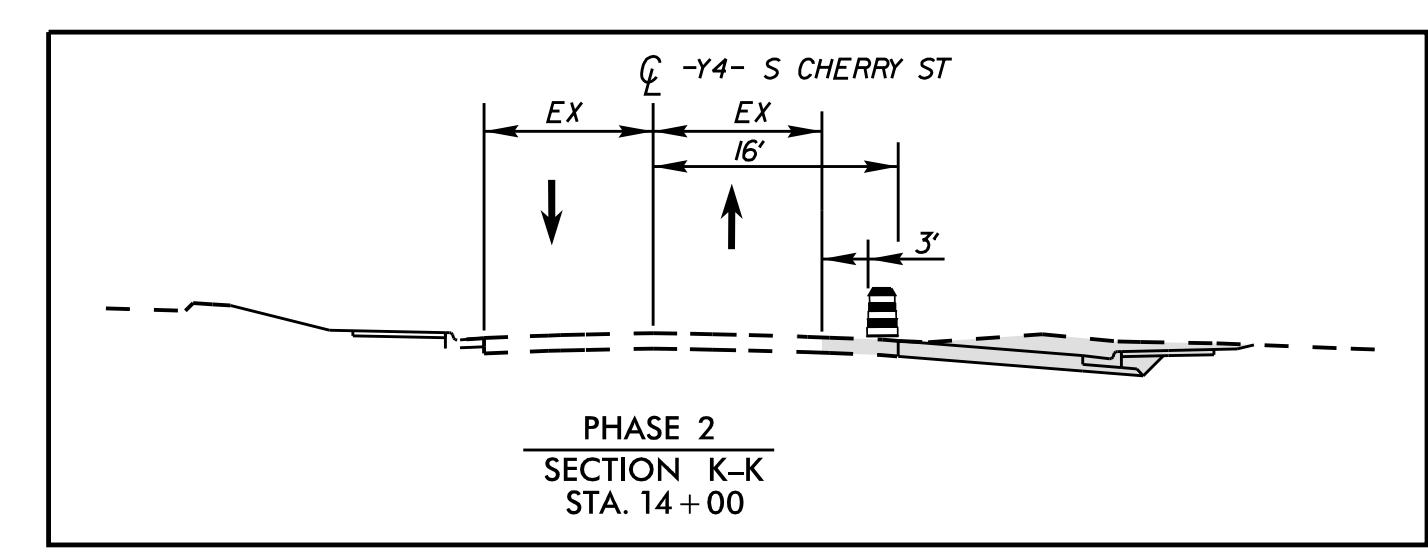
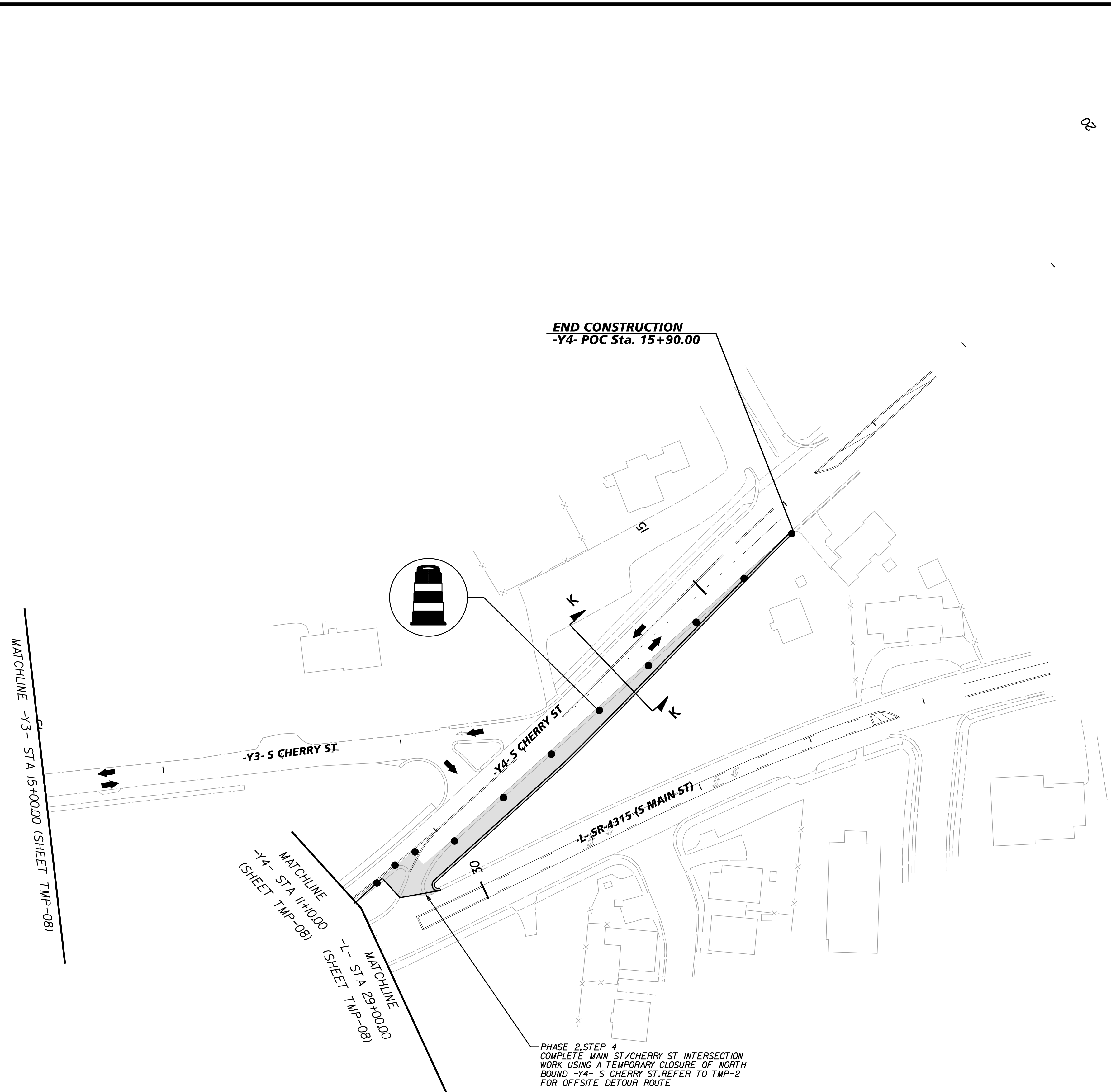

- WORK AREA
- PAVEMENT REMOVAL
- WEDGING

DOCUMENT NOT CONSIDERED FINAL
UNLESS ALL SIGNATURES COMPLETED

APPROVED: _____ DATE: _____

SEAL

DocuSigned by:
Matt West
1/4/2016

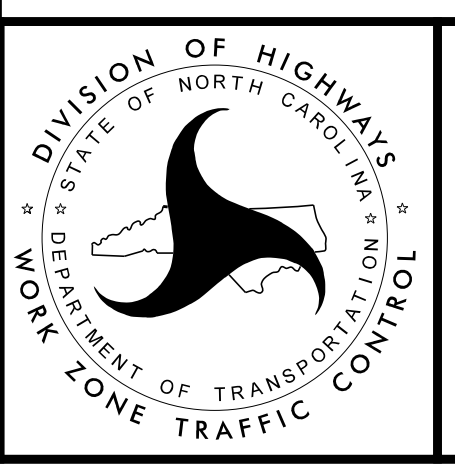

TRAFFIC CONTROL PHASE II

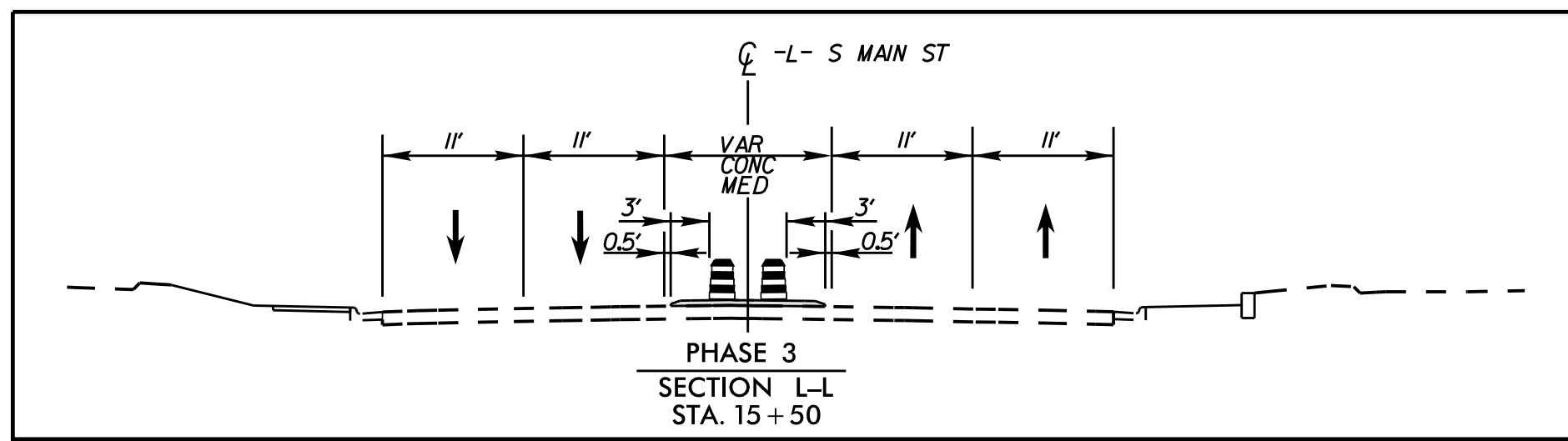
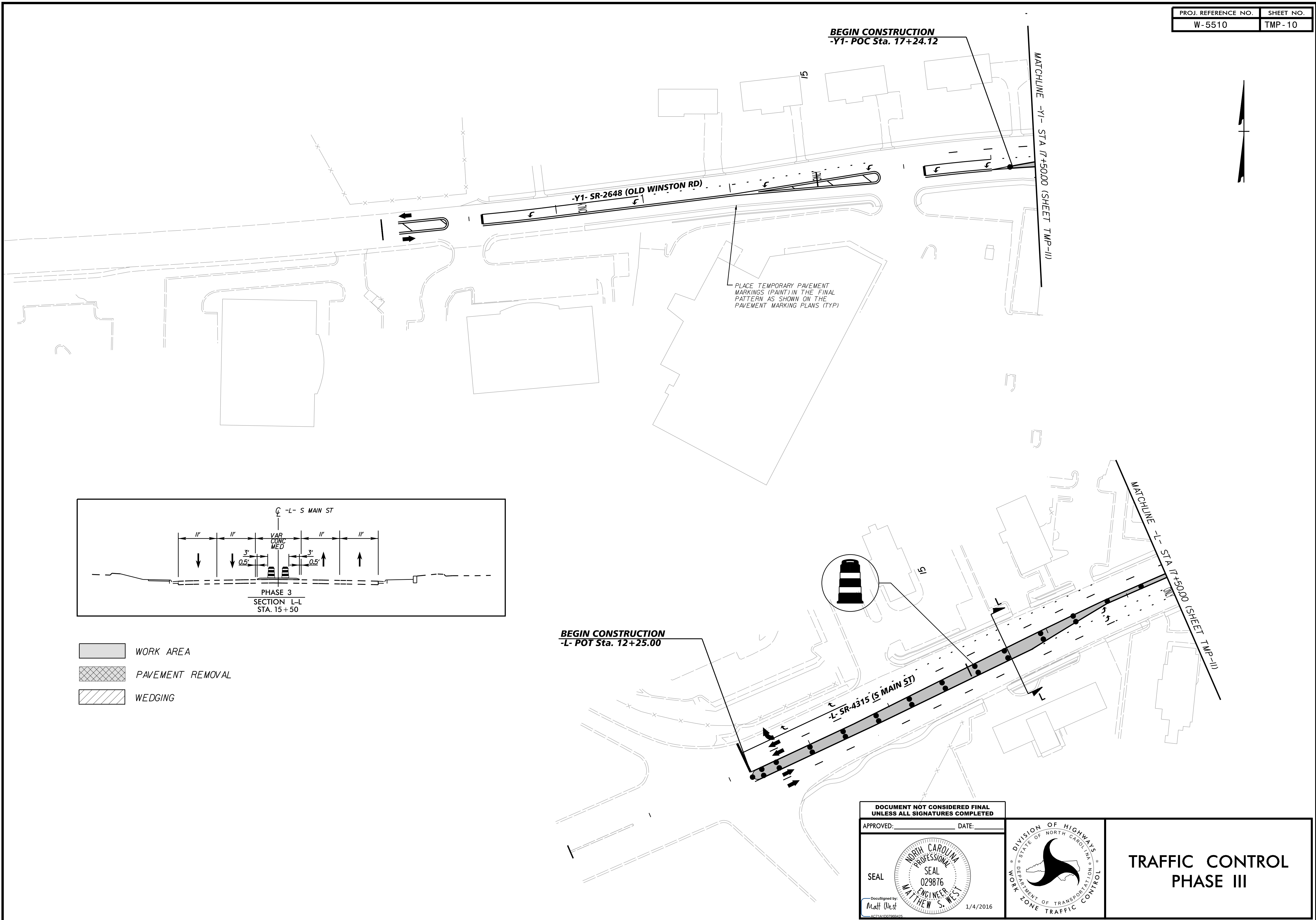
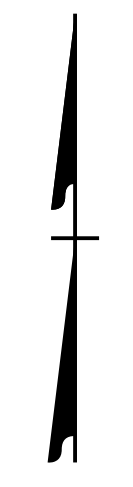

- WORK AREA
- PAVEMENT REMOVAL
- WEDGING



DOCUMENT NOT CONSIDERED FINAL
UNLESS ALL SIGNATURES COMPLETED

APPROVED: _____ DATE: _____

SEAL

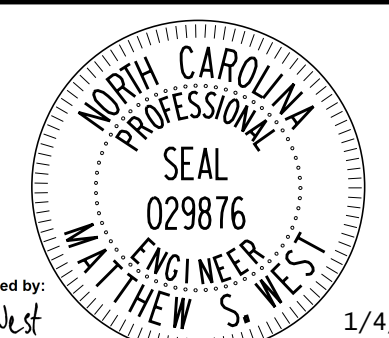

Dec designed by
Matt West
1/4/2016

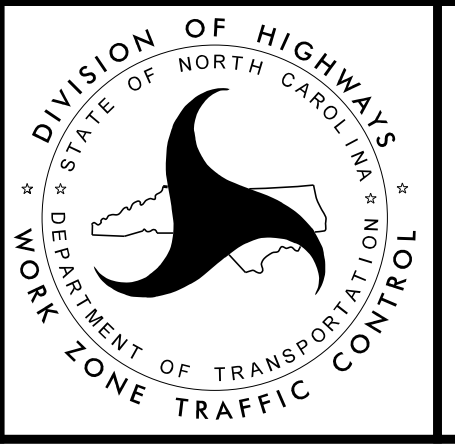

**TRAFFIC CONTROL
PHASE III**

K:\RAL_Roadway\01036245 - Kernersville\leTrafficControl\CPNTMP\W5510_TMP_PSH0.dgn 12/22/2015

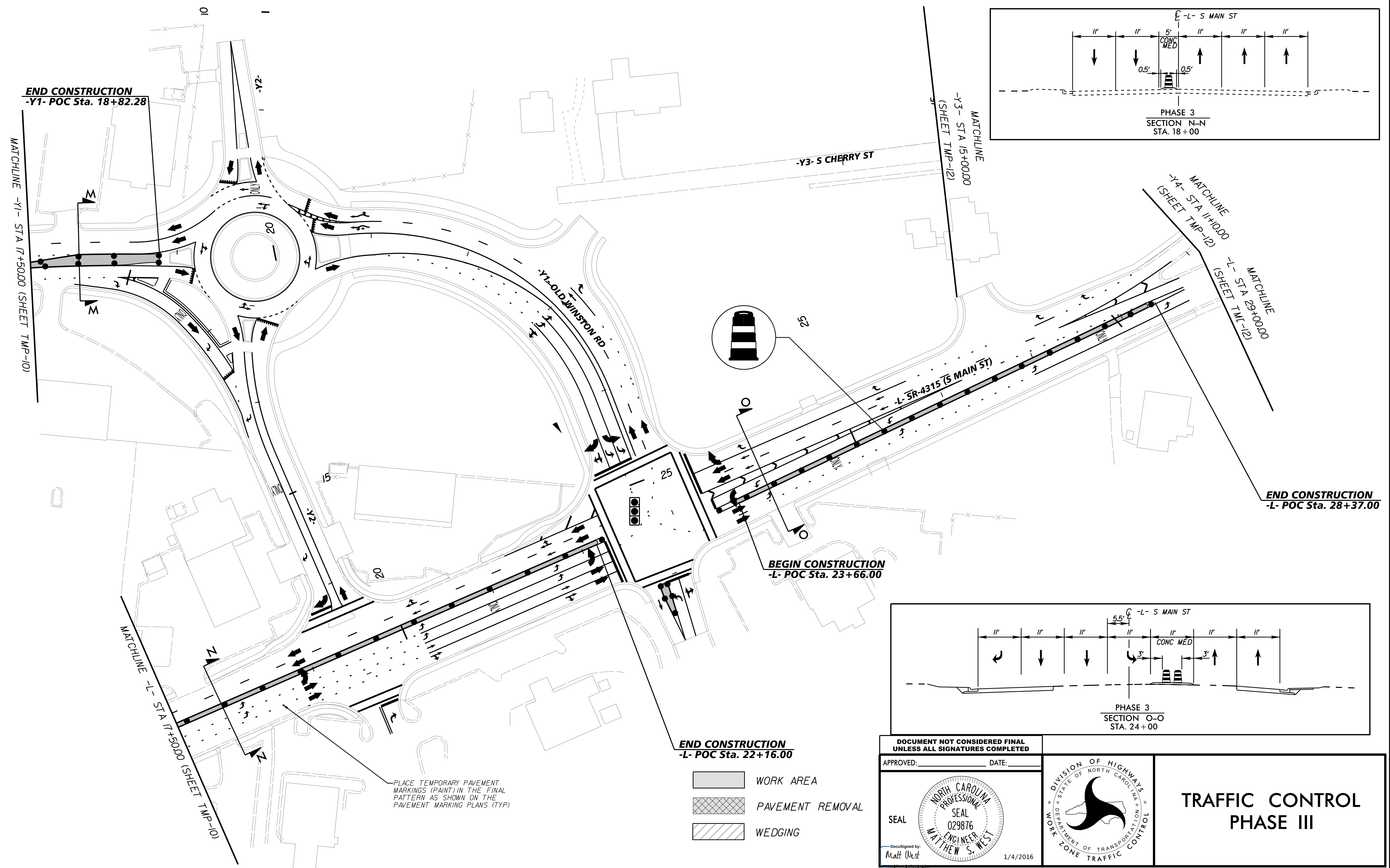
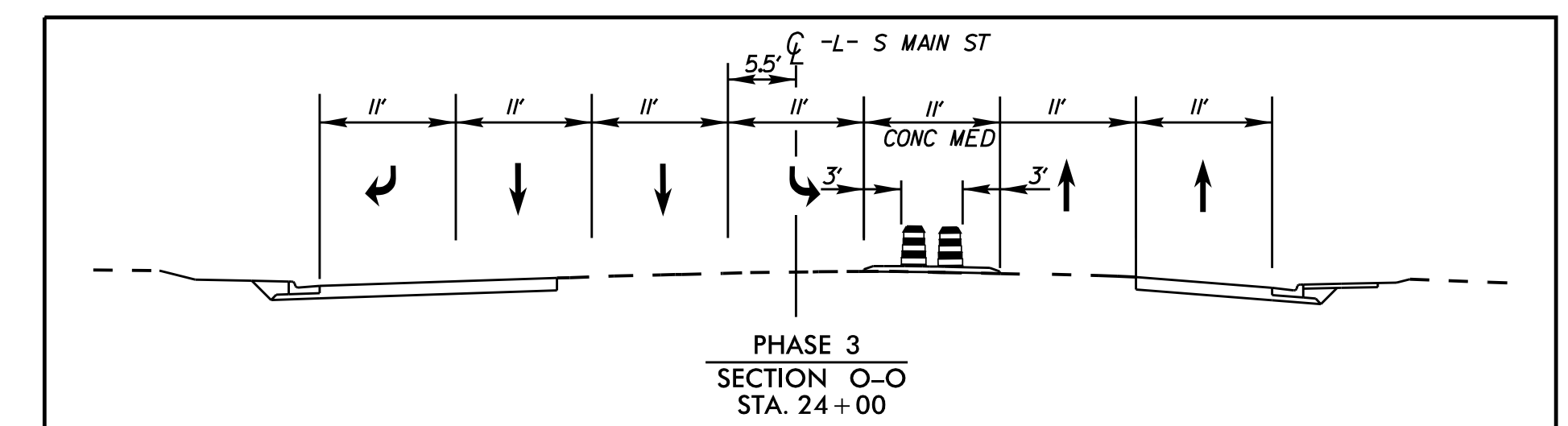
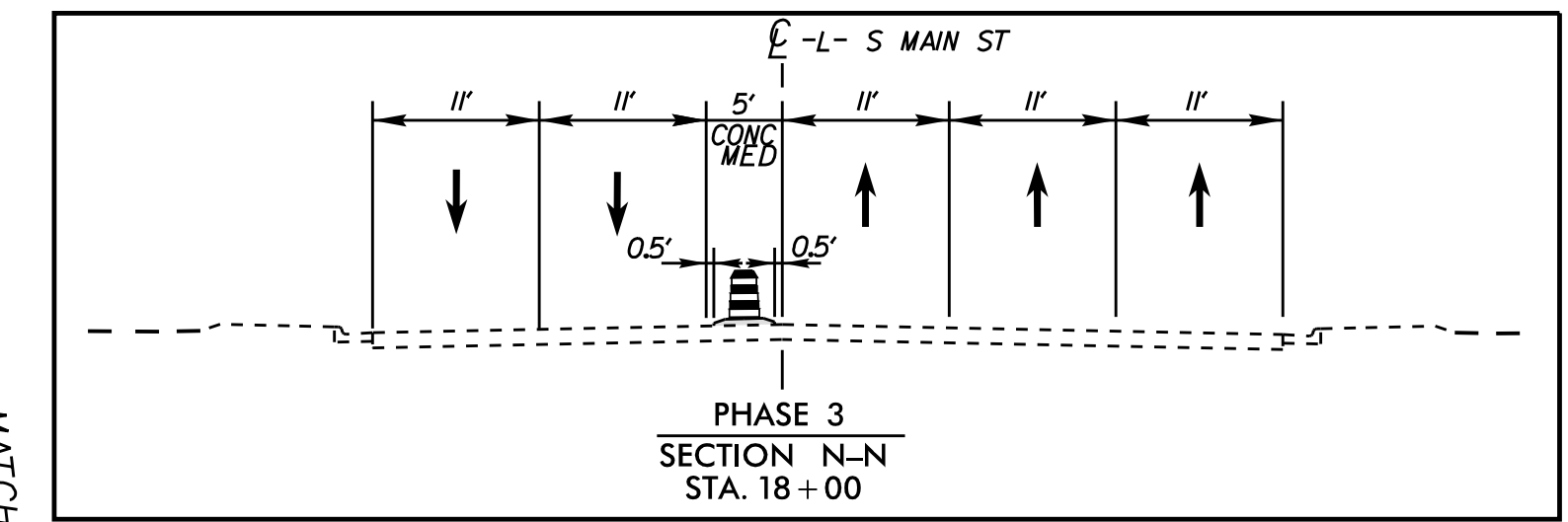
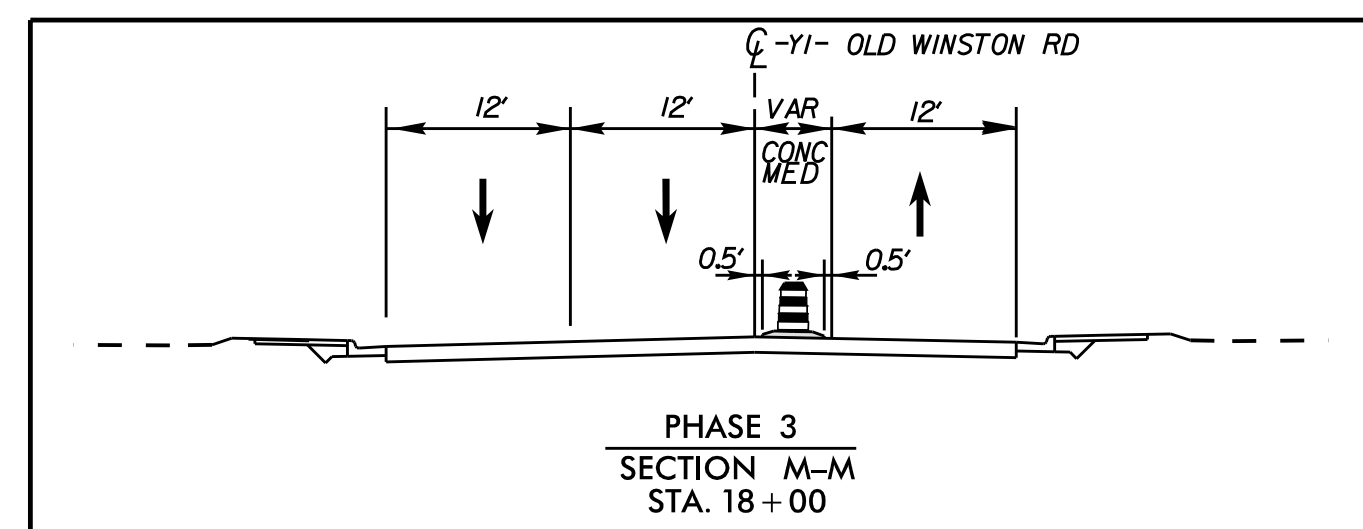

DOCUMENT NOT CONSIDERED FINAL
UNLESS ALL SIGNATURES COMPLETED

APPROVED: _____ DATE: _____

SEAL

 DocuSigned by:
 Matt West
 1/4/2016

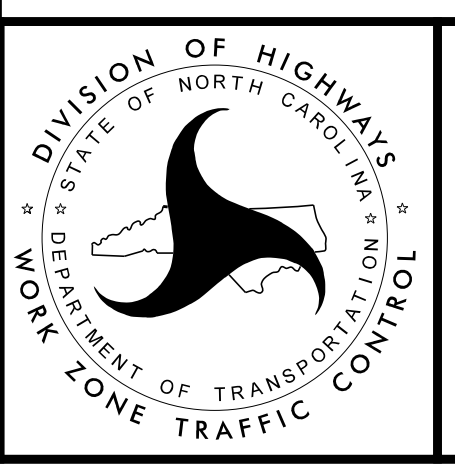

**TRAFFIC CONTROL
PHASE III**

20

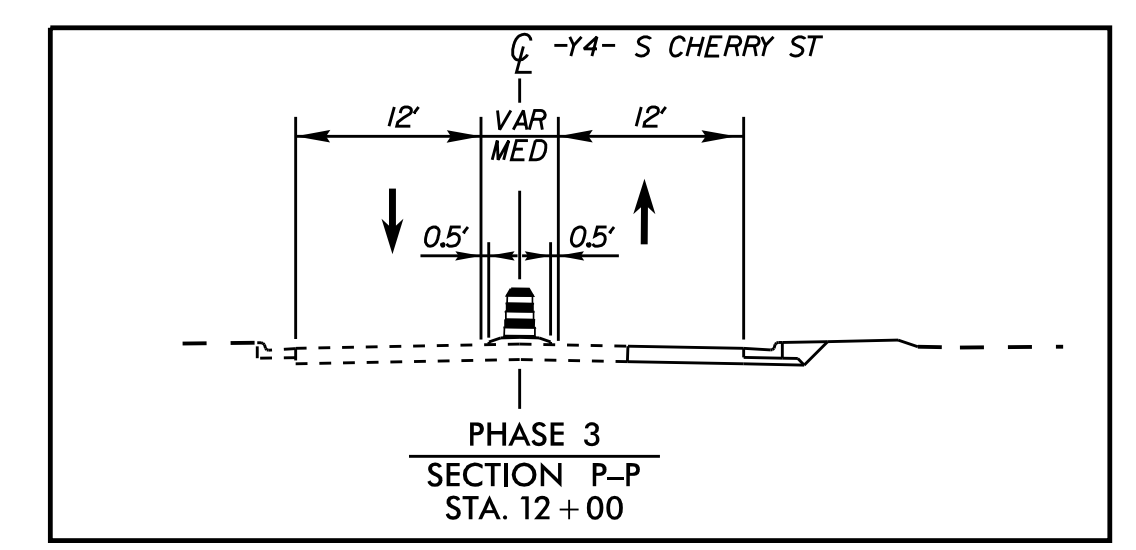
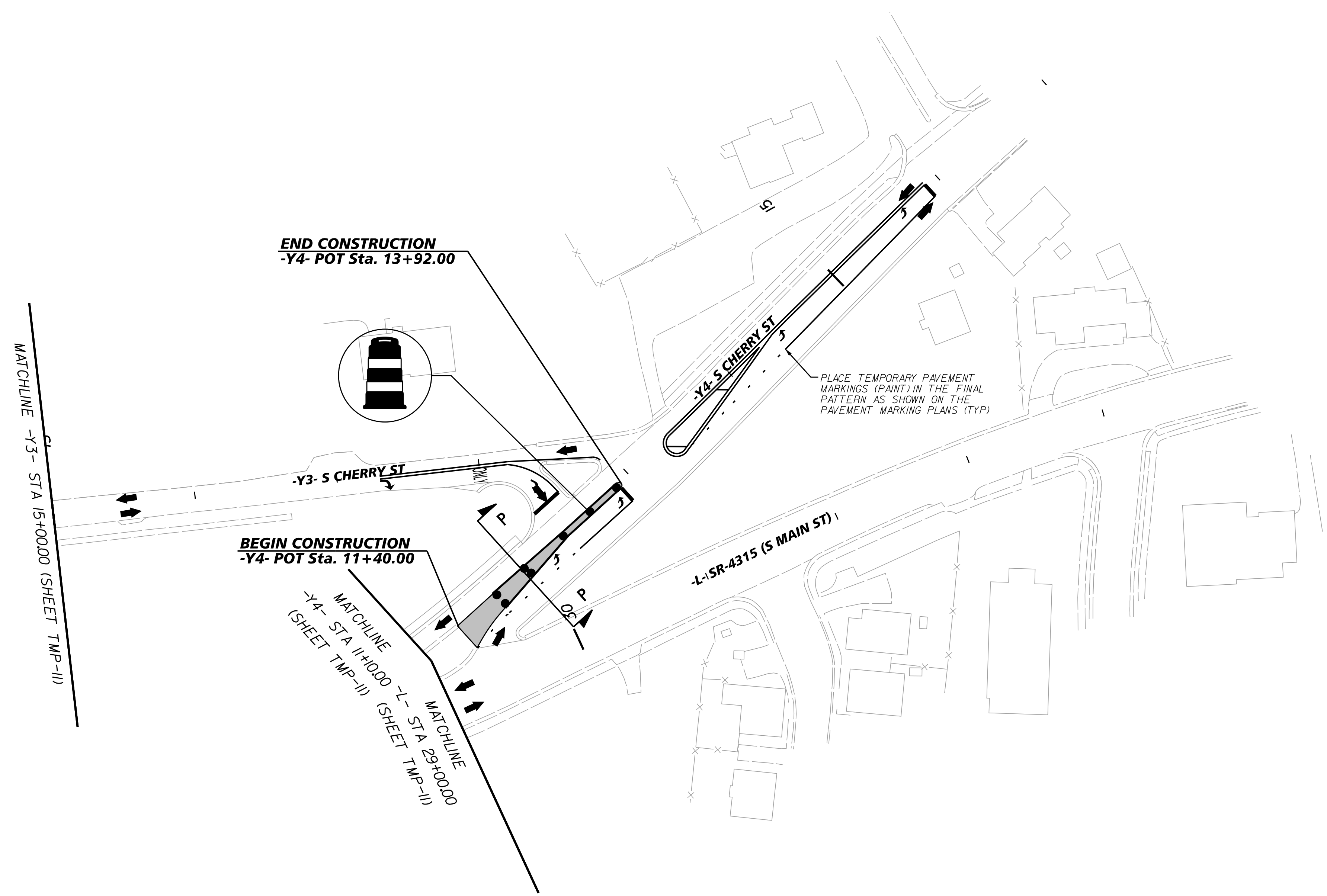

K:\RAL_Roadway\01036245 - Kernersville\TrafficControl\TPT\W5510_TMP_PSH12.dgn 12/22/2015

DOCUMENT NOT CONSIDERED FINAL
UNLESS ALL SIGNATURES COMPLETED

APPROVED: _____ DATE: _____

SEAL

 Dec designed by
 Matt West
 1/4/2016

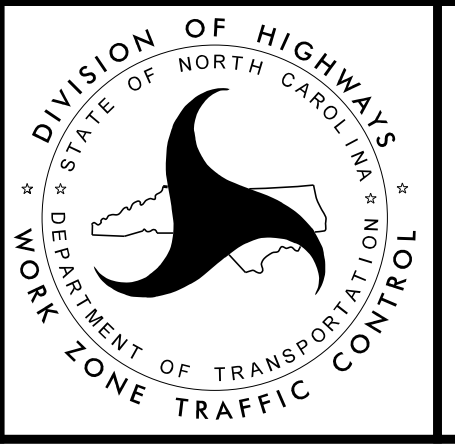

TRAFFIC CONTROL PHASE III

