

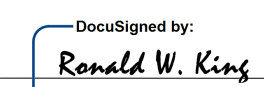

PROJECT REFERENCE NO. U-3308	SHEET NO. PMP-1
APPROVED:  069507AB97C4DC	
DATE: 4/6/2015	
SEAL 	

**STATE OF NORTH CAROLINA
DEPARTMENT OF TRANSPORTATION**

**PAVEMENT MARKING PLAN
DURHAM COUNTY**

**LOCATION: NC 55 (ALSTON AVE) FROM NC 147 (I.L."BUCK" DEAN FREEWAY) TO
NORTH OF US 70 BUS /NC 98 (HOLLOWAY ST)**

T.I.P.: U-3308

CONTRACT: C203567

ROADWAY STANDARD DRAWING

THE FOLLOWING ROADWAY STANDARDS AS APPEAR IN "ROADWAY STANDARD DRAWINGS" - PROJECT SERVICES UNIT - N.C. DEPARTMENT OF TRANSPORTATION - RALEIGH, N.C., DATED JANUARY 2012 ARE APPLICABLE TO THIS PROJECT AND BY REFERENCE HEREBY ARE CONSIDERED A PART OF THESE PLANS:

STD. NO.	TITLE
1205.01	PAVEMENT MARKINGS - LINE TYPES AND OFFSETS
1205.02	PAVEMENT MARKINGS - TWO-LANE AND MULTILANE ROADWAYS
1205.03	PAVEMENT MARKINGS - EXIT AND ENTRANCE RAMP
1205.04	PAVEMENT MARKINGS - INTERSECTIONS
1205.05	PAVEMENT MARKINGS - TURN LANES
1205.06	PAVEMENT MARKINGS - LANE DROPS
1205.08	PAVEMENT MARKINGS - SYMBOLS AND WORD MESSAGES
1205.09	PAVEMENT MARKINGS - PAINTED ISLANDS
1205.10	PAVEMENT MARKINGS - SCHOOL AREAS
1205.12	PAVEMENT MARKINGS - BRIDGES
1250.01	RAISED PAVEMENT MARKERS - INSTALLATION SPACING
1251.01	RAISED PAVEMENT MARKERS - PERMANENT AND TEMPORARY
1261.01	GUARDRAIL AND BARRIER DELINEATORS - INSTALLATION SPACING
1261.02	GUARDRAIL AND BARRIER DELINEATORS - TYPES AND MOUNTING
1262.01	GUARDRAIL END DELINEATION
1264.01	OBJECT MARKERS - TYPES
1264.02	OBJECT MARKERS - INSTALLATION

GENERAL NOTES

THE FOLLOWING GENERAL NOTES APPLY AT ALL TIMES FOR THE DURATION OF THE CONSTRUCTION PROJECT, EXCEPT WHEN OTHERWISE NOTED IN THE PLAN, OR DIRECTED BY THE ENGINEER.

- A) INSTALL PAVEMENT MARKINGS AND PAVEMENT MARKERS ON THE FINAL SURFACE AS FOLLOWS:

ROAD NAME	MARKING	MARKER
NC 55, Y-LINES, AND RAMP	THERMOPLASTIC	RAISED
CONCRETE BRIDGE DECK	COLD APPLIED PLASTIC (TYPE II OR III)	RAISED
- B) TIE PROPOSED PAVEMENT MARKING LINES TO EXISTING PAVEMENT MARKING LINES.
- C) REMOVE/REPLACE ANY CONFLICTING/DAMAGED PAVEMENT MARKINGS AND MARKERS.
- D) PASSING ZONES WILL BE DETERMINED IN THE FIELD AND MUST BE APPROVED BY THE ENGINEER.
- E) STOP BAR LOCATION AT NON-SIGNALIZED INTERSECTIONS MAY BE ADJUSTED AS DIRECTED BY THE ENGINEER.
- F) REMOVE ALL RESIDUE AND SURFACE LAITANCE BY ACCEPTABLE METHODS ON CONCRETE BRIDGE DECKS PRIOR TO PLACING (insert marking material) PAVEMENT MARKING MATERIAL.
- G) UNLESS OTHERWISE SPECIFIED, HEATED-IN-PLACE THERMOPLASTIC MAY BE USED IN LIEU OF EXTRUDED THERMOPLASTIC FOR STOP BARS, SYMBOLS, CHARACTERS AND DIAGONALS. IF HEATED-IN-PLACE IS USED, IT SHALL BE PAID FOR USING THE EXTRUDED THERMOPLASTIC PAY ITEM.
- H) UNLESS OTHERWISE SPECIFIED, HEATED-IN-PLACE THERMOPLASTIC MAY BE USED IN LIEU OF COLD APPLIED PLASTIC FOR STOP BARS, SYMBOLS, CHARACTERS AND DIAGONALS ON ASPHALT OR CONCRETE ROADWAYS. IF HEATED-IN-PLACE IS USED, IT SHALL BE PAID FOR USING THE COLD APPLIED PAY ITEM.
- I) ALL BIKE LANE SYMBOLS SHALL BE HEATED-IN-PLACE THERMOPLASTIC. SYMBOLS SHALL BE PAID FOR USING THE HEAT-IN-PLACE PAY ITEM.
- J) TYPE III COLD APPLIED PLASTIC MAY BE USED IN LIEU OF TYPE II COLD APPLIED PLASTIC. IF TYPE III COLD APPLIED PLASTIC IS USED, IT SHALL BE PAID FOR USING THE TYPE II COLD APPLIED PLASTIC PAY ITEM.
- K) SEE ROADWAY PLANS FOR ALTERNATE CURB RAMP DESIGNS WHEN INDICATED ON PAVEMENT MARKING DETAIL SHEETS.

INDEX



SHEET NO.	DESCRIPTION
PMP-1	PAVEMENT MARKING PLAN TITLE
PMP-1A	SCHEDULE SHEET
PMP-2-2B	CROSSWALK PAVEMENT MARKING GUIDANCE DETAIL AND REVISED PAVEMENT MARKING STANDARDS
PMP-3-9	PAVEMENT MARKING DETAIL

PLAN PREPARED BY: N.C.D.O.T. SIGNING AND DELINEATION UNIT

RENEE B. ROACH, P.E. SIGNING & DELINEATION REGIONAL ENGINEER

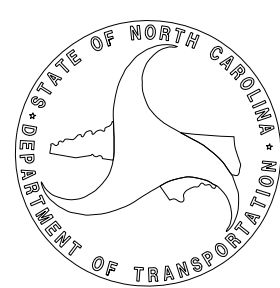
STACEY W. JOHNS SIGNING & DELINEATION PROJECT DESIGN ENGINEER

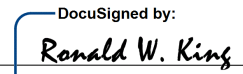

PROJECT REFERENCE NO. U-3308	SHEET NO. PMP-1A
APPROVED:  068507A8577C4DC	
DATE: 4/6/2015	
SEAL	
	

PAVEMENT MARKING SCHEDULE

SYMBOL	DESCRIPTION	SYMBOL	DESCRIPTION
	THERMO(24", 120 MILS)		COLD APPLIED PLASTIC(4")
T2	WHITE STOPBAR	CC	10 FT. WHITE SKIP
T3	WHITE CROSSWALK LINE	CD	3 FT. - 9 FT./SP WHITE MINISKIP
		CE	WHITE SOLID LANE LINE
		CI	YELLOW DOUBLE CENTER
	THERMO(4", 120 MILS)		
T8	2 FT. - 6 FT./SP WHITE MINISKIP		
TC	10 FT. WHITE SKIP		COLD APPLIED PLASTIC(8")
TD	3 FT. - 9 FT./SP WHITE MINISKIP		
TE	WHITE SOLID LANE LINE	C13	3 FT. - 9 FT./SP WHITE MINISKIP
TI	YELLOW DOUBLE CENTER	CP	YELLOW DIAGONAL
		CR	WHITE SOLID LANE LINE
	THERMO(4", 90 MILS)		
TA	WHITE EDGELINE		COLD APPLIED PLASTIC MARKING CHARACTER
TB	YELLOW EDGELINE		
	THERMO(6", 120 MILS)	DI	ALPHANUMERIC CHAR.
T11	2 FT. - 6 FT./SP WHITE MINISKIP		COLD APPLIED PLASTIC PAVEMENT MARKING SYMBOLS
TL	WHITE SOLID LANE LINE		
	THERMO(8", 120 MILS)	DA	LEFT TURN ARROW
		DB	RIGHT TURN ARROW
		DC	STRAIGHT ARROW
T13	3 FT. - 9 FT./SP WHITE MINISKIP		PERMANENT RAISED PAVEMENT MARKERS
TQ	WHITE CROSSWALK LINE		
TR	WHITE SOLID LANE LINE		
	THERMO(8", 90 MILS)	MA	YELLOW & YELLOW
		MB	CRYSTAL & RED
TN	WHITE GORELINE		
TP	YELLOW DIAGONAL		
	THERMOPAVEMENT MARKING CHARACTER (120 MILS)		
UI	ALPHANUMERIC CHAR.		
	THERMOPAVEMENT MARKING SYMBOLS (90 MILS)		
UA	LEFT TURN ARROW		
UB	RIGHT TURN ARROW		
UC	STRAIGHT ARROW		
UD	COMBO. LEFT/STRAIGHT ARROW		
UE	COMBO. RIGHT/STRAIGHT ARROW		
UJ	BICYCLE SYMBOL		
UK	BICYCLE STRAIGHT ARROW		
UN	24" YIELD LINE TRIANGLE		

4/6/2015
 P:\Projects-U\U3308-Traffic\Signing\CADD\PMF-U-3308_PMF-1.dgn
 User: jchris

PAVEMENT MARKING SCHEDULE

UNLESS OTHERWISE SPECIFIED,
HI-VISIBILITY CROSSWALK
MARKINGS SHALL BE USED AT
MID-BLOCK CROSSINGS

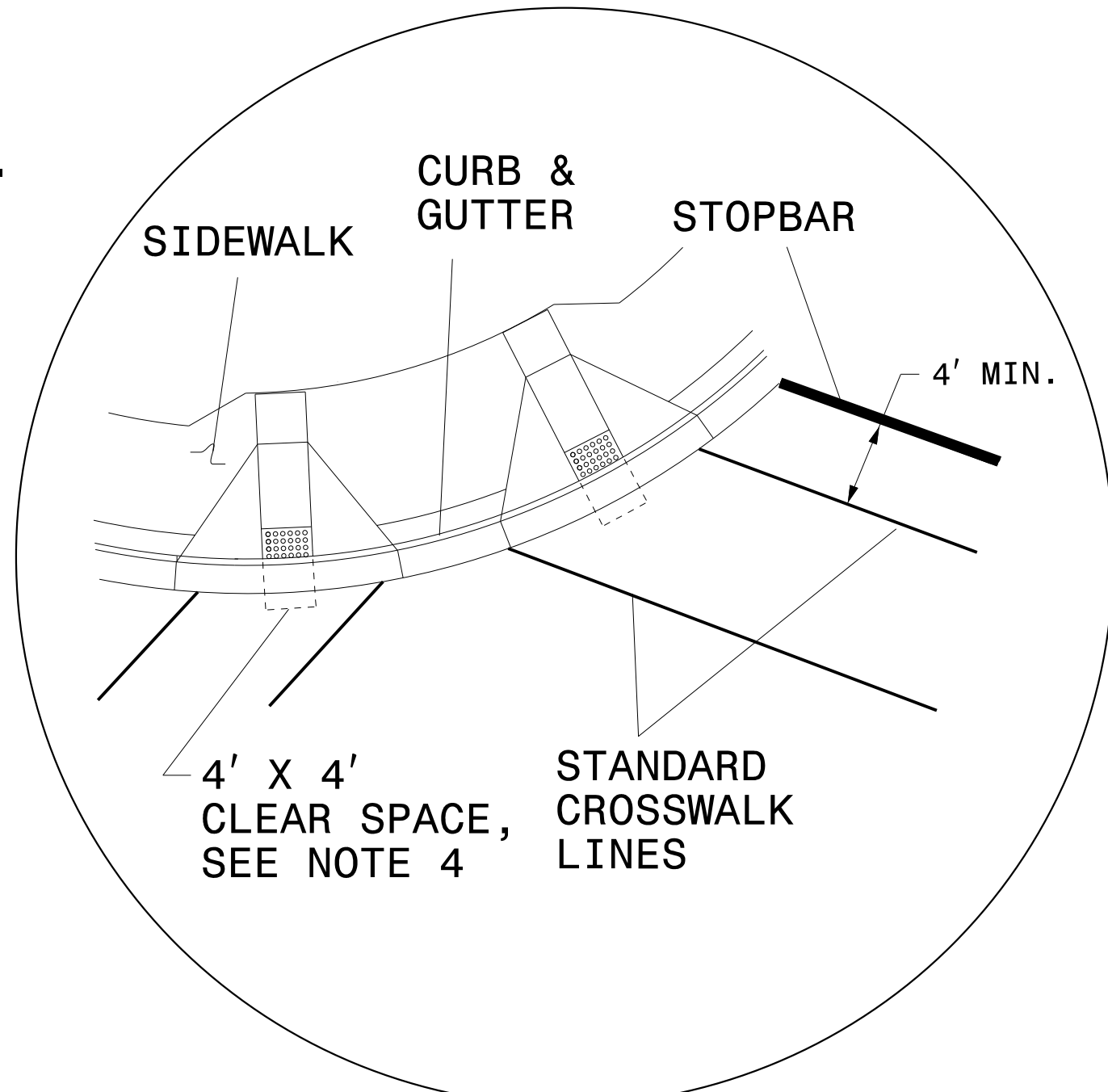
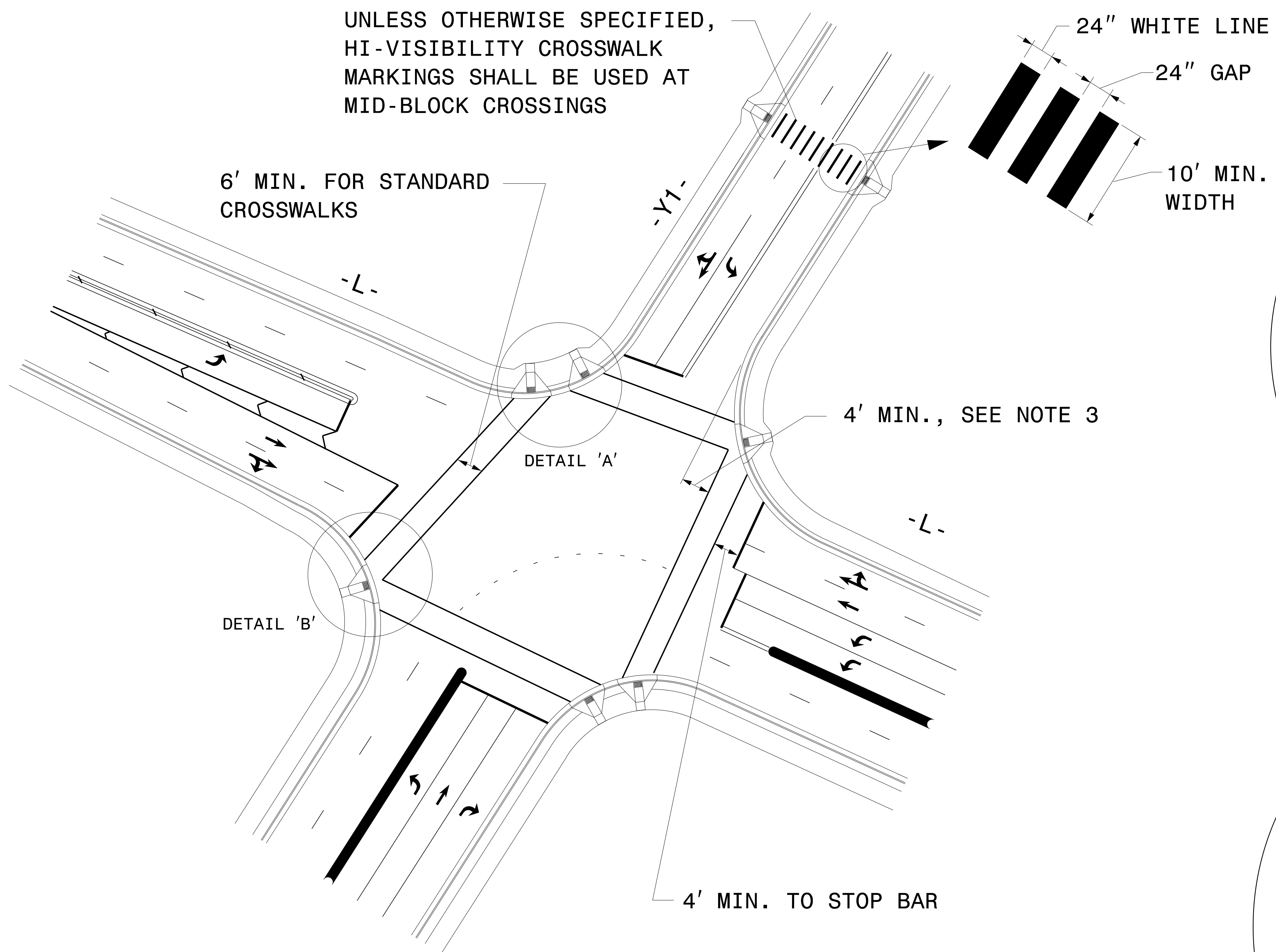

DETAIL 'A'- DUAL CURB RAMPS

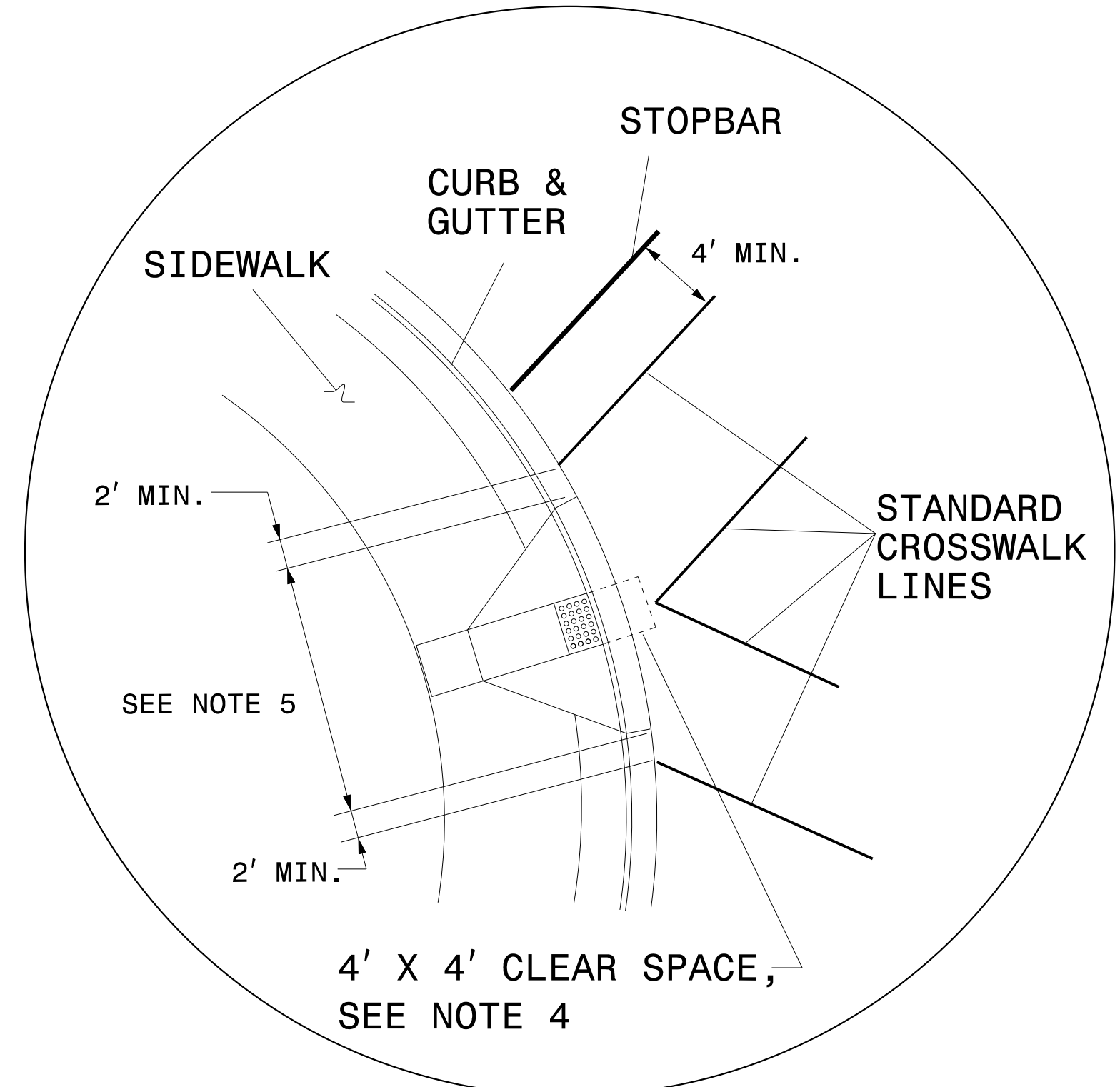

DETAIL 'B'- SINGLE DIAGONAL CURB RAMP

GUIDANCE DETAIL FOR CROSSWALK MARKINGS

NOTES:

1. USE THE DETAILS ABOVE AND THE FOLLOWING NOTES FOR GUIDANCE IN PLACING CROSSWALK MARKINGS NOT STATIONED ON THE DETAIL SHEETS OR WHEN FIELD ADJUSTMENTS REQUIRED MOVING STATIONED MARKINGS AS DIRECTED BY THE ENGINEER. REFER TO NCDOT ROADWAY STANDARD DRAWINGS, MUTCD AND ADA STANDARDS FOR ADDITIONAL GUIDANCE.
2. THE CROSSWALK MARKINGS SHOWN ON THE ABOVE DETAILS ARE FOR REFERENCE ONLY. ONLY INSTALL CROSSWALK MARKINGS WHERE SHOWN ON THE DETAIL SHEETS OR AS DIRECTED BY THE ENGINEER. THE CROSSWALK MARKING TYPE, STANDARD OR HI-VISIBILITY, SHALL BE INSTALL AS SPECIFIED ON THE DETAIL SHEETS OR AS DIRECTED BY THE ENGINEER.
3. SET BACK DISTANCE FROM INSIDE CROSSWALK MARKING TO NEAREST EDGE OF TRAVEL IS 4' MIN.
4. BEYOND THE BOTTOM GRADE BRAKE, A CLEAR SPACE OF 4' X 4' MINIMUM SHALL BE PROVIDED WITHIN THE MARKINGS.
5. SINGLE DIAGONAL CURB RAMPS WITH FLARED SIDES SHALL HAVE A SEGMENT OF CURB 2 FEET LONG MINIMUM LOCATED ON EACH SIDE OF THE CURB RAMP AND WITHIN THE MARKED CROSSING, SEE DETAIL 'B'.
6. CURB RAMPS SHALL BE CONSTRUCTED IN ACCORDANCE TO THE LATEST NCDOT ROADWAY STANDARD DRAWINGS.

**CROSSWALK PAVEMENT MARKING
GUIDANCE DETAIL**

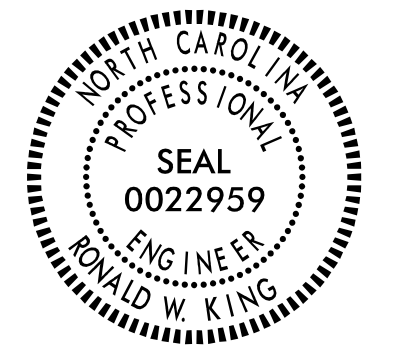

STATE OF NORTH CAROLINA
 DEPT. OF TRANSPORTATION
 DIVISION OF HIGHWAYS
 RALEIGH, N.C.

1-12

LANE DROP AT AN INTERSECTION

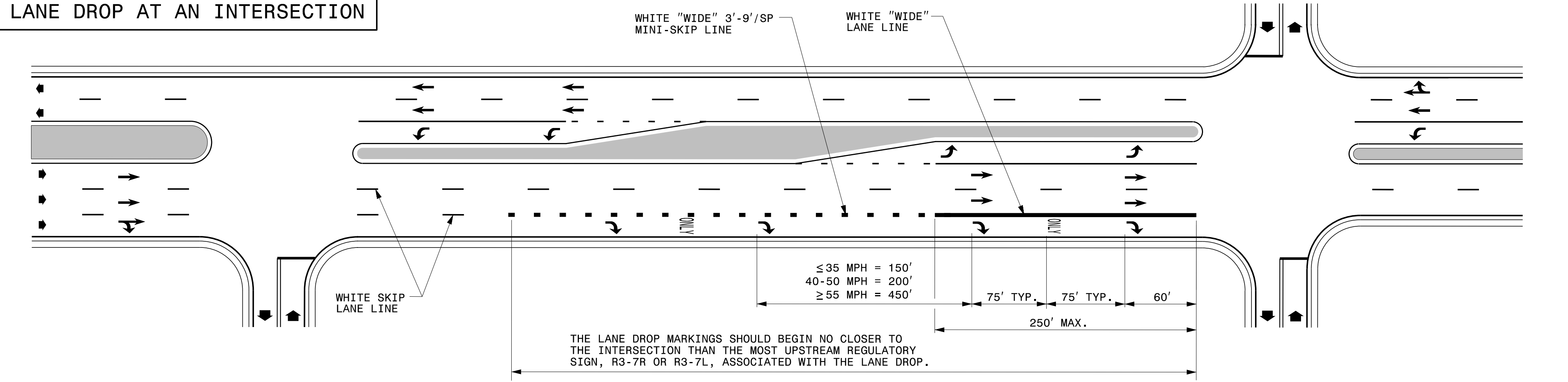

STATE OF NORTH CAROLINA
 DEPT. OF TRANSPORTATION
 DIVISION OF HIGHWAYS
 RALEIGH, N.C.

1-12

ENGLISH DETAIL DRAWING FOR
 PAVEMENT MARKINGS
 LANE DROPS

LANE DROP AT AN INTERSECTION WITH AN AUXILIARY LANE

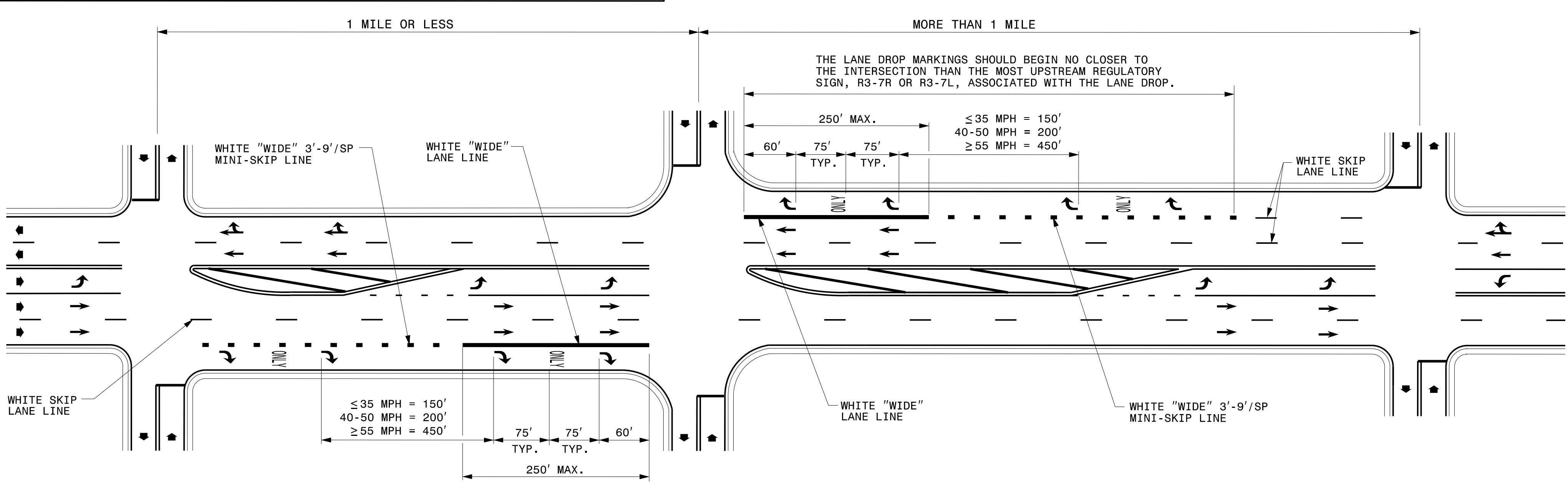

ENGLISH DETAIL DRAWING FOR
 PAVEMENT MARKINGS
 LANE DROPS

GENERAL NOTES:

- USE THE GUIDANCE SHOWN ON THE ABOVE DETAILS IN CONJUNCTION WITH INTERSECTION GUIDANCE SHOWN ON ROADWAY STANDARD DRAWING 1205.04.
- LANE LINES INDICATED AS "WIDE" SHALL BE AT LEAST TWICE THE WIDTH OF THE NORMAL LINE.

LEGEND	
W = WIDTH OF TRAVEL LANE	ONLY PAVEMENT MARKING SYMBOLS & CHARACTERS
➔ DIRECTION OF TRAFFIC FLOW	

SHEET 1 OF 3
1205D06

SHEET 1 OF 3
1205D06

**REVISED PAVEMENT MARKING
 ROADWAY STANDARD DRAWING**

STATE OF NORTH CAROLINA
DEPT. OF TRANSPORTATION
DIVISION OF HIGHWAYS
RALEIGH, N.C.

ENGLISH DETAIL DRAWING FOR
PAVEMENT MARKINGS
SYMBOLS AND WORD MESSAGES

SHEET 3 OF 8
1205D08

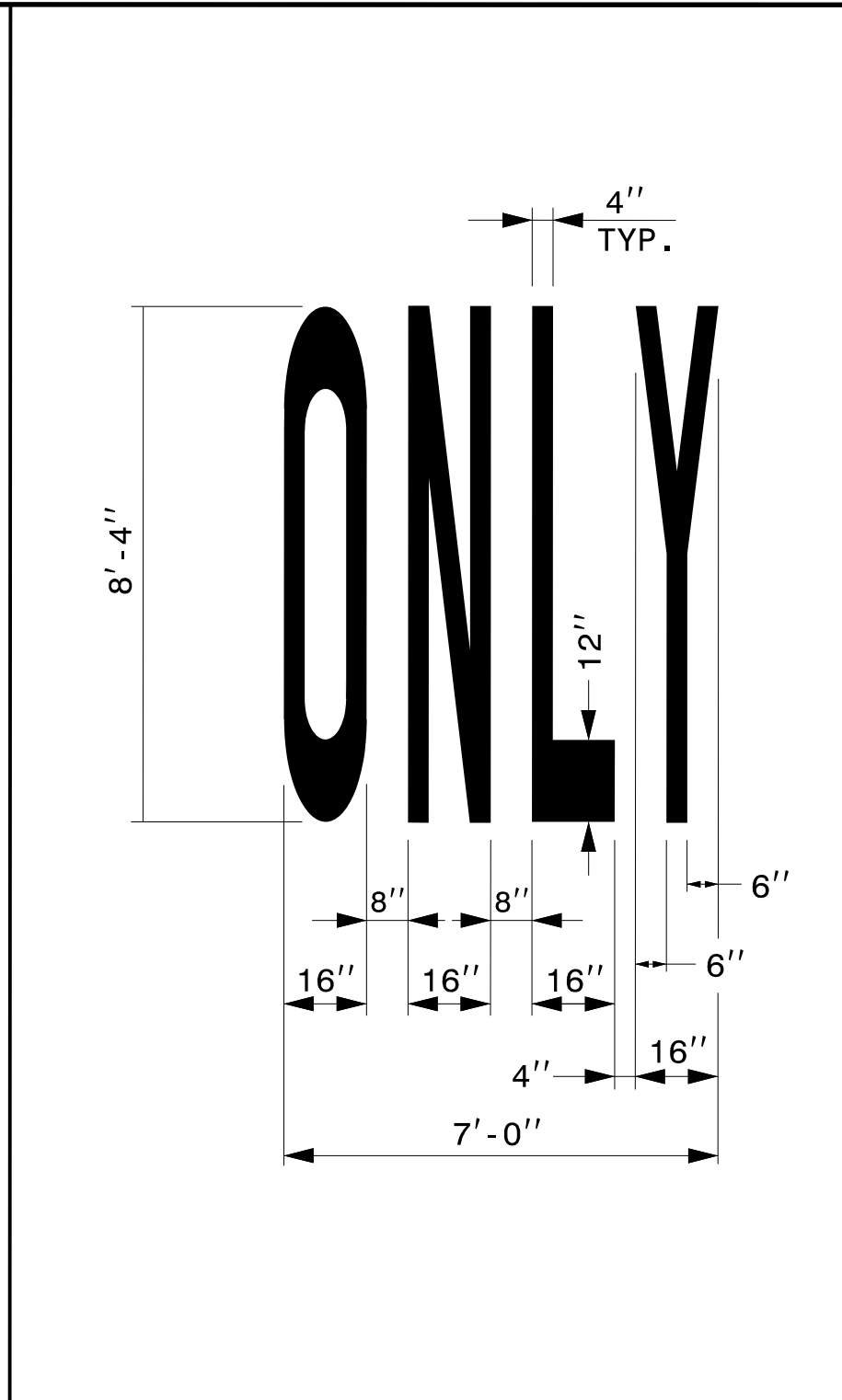
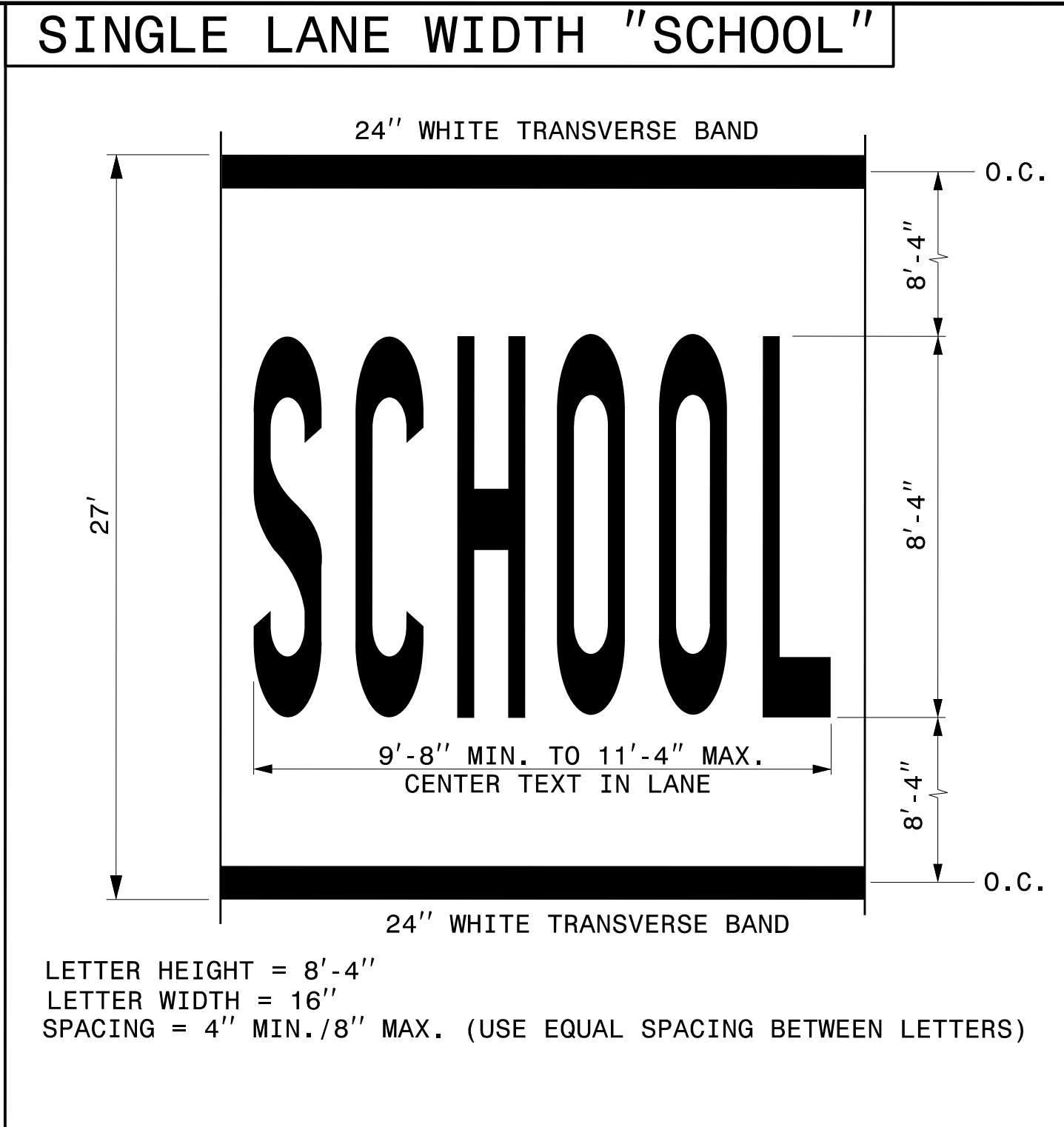
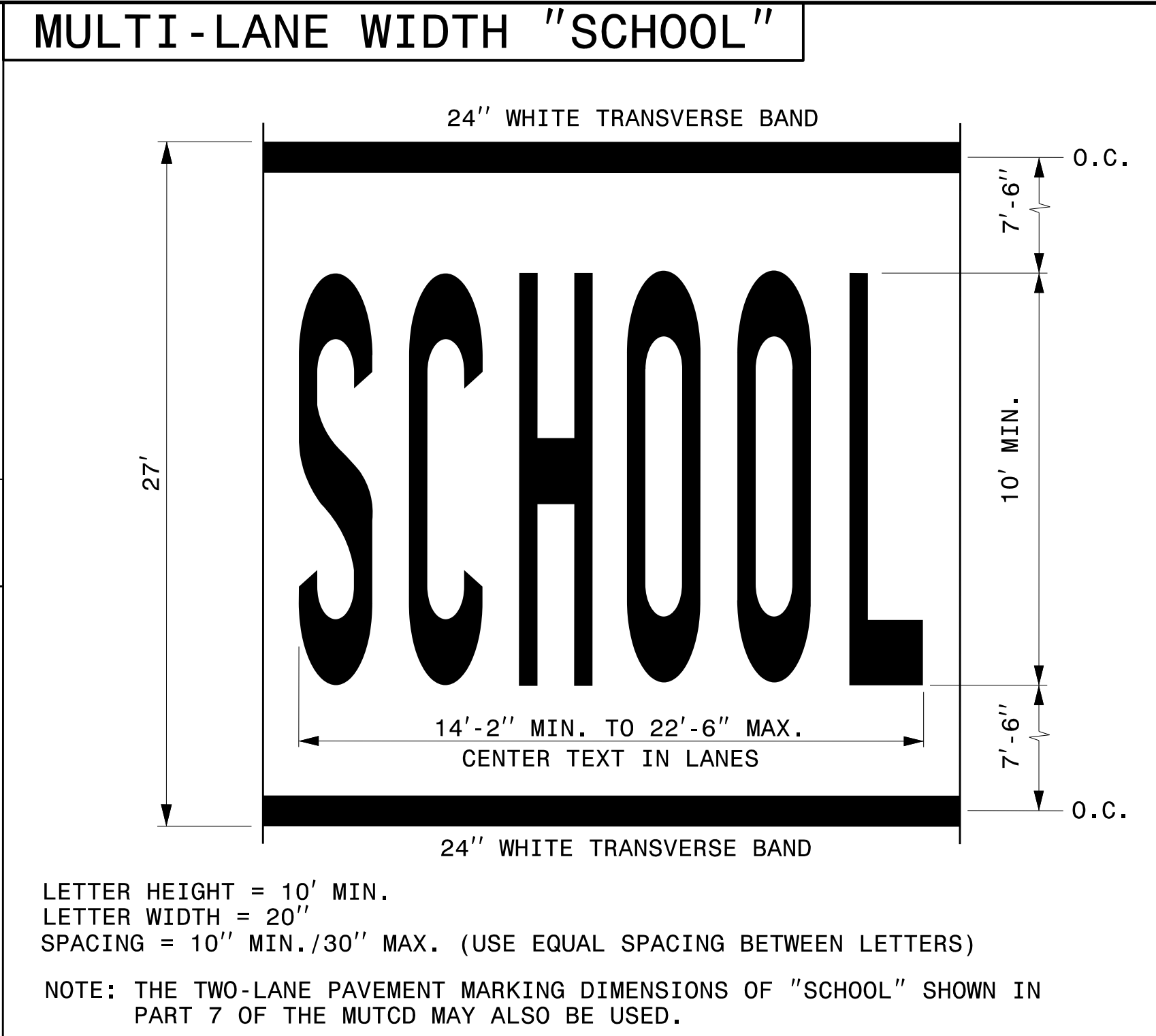

STATE OF NORTH CAROLINA
DEPT. OF TRANSPORTATION
DIVISION OF HIGHWAYS
RALEIGH, N.C.

ENGLISH DETAIL DRAWING FOR
PAVEMENT MARKINGS
SYMBOLS AND WORD MESSAGES

SHEET 3 OF 8
1205D08

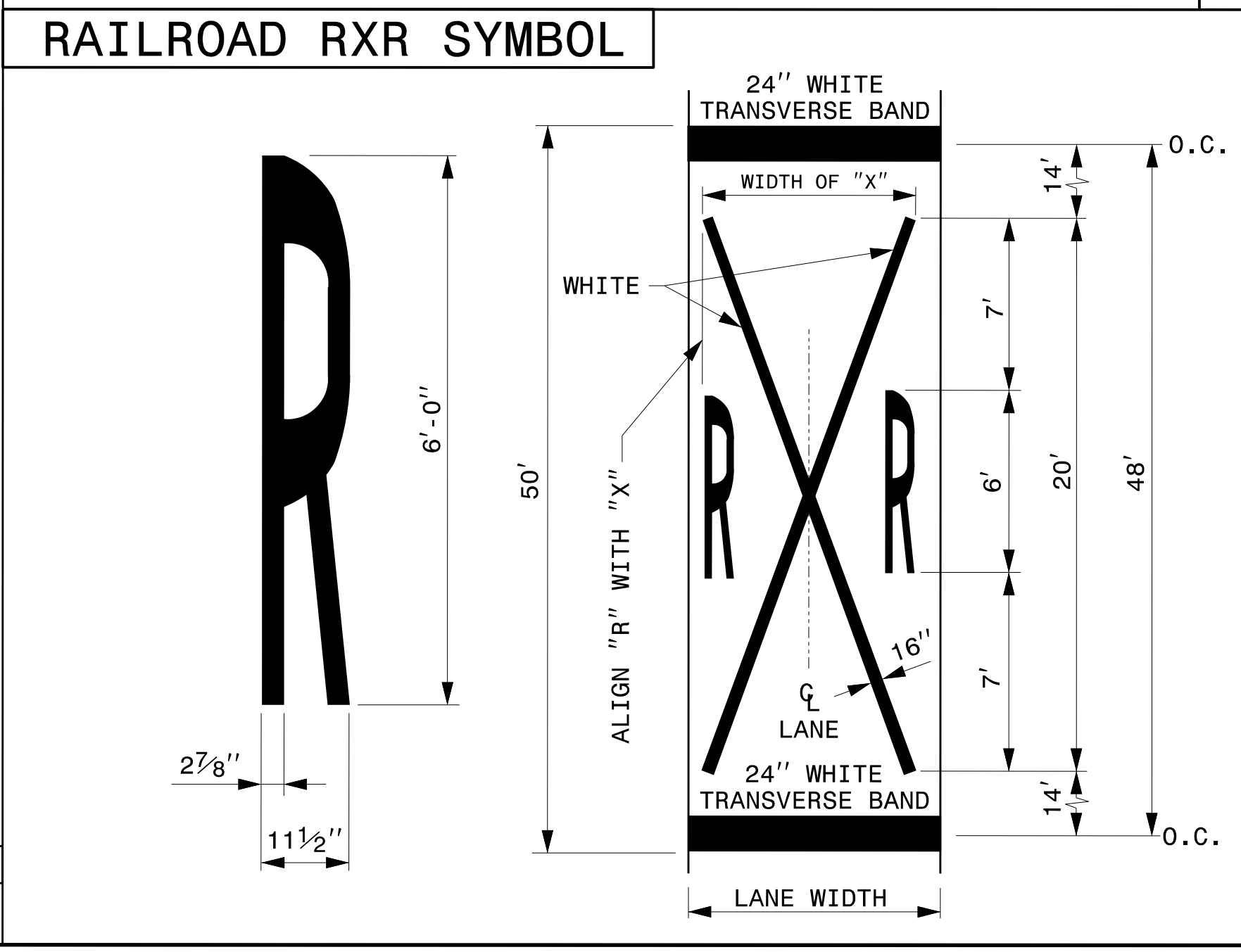

GENERAL NOTES:

- THE SCHOOL PAVEMENT MARKING CONSISTS OF SIX (6) CHARACTERS. THE TWO (2) 24" TRANSVERSE BANDS WILL BE PAID FOR UNDER A SEPARATE PAY ITEM. REFER TO ROADWAY STANDARD DRAWING 1205.10 FOR ADDITIONAL PAVEMENT MARKING GUIDANCE.
- PAVEMENT MARKING IN ADVANCE OF A HIGHWAY-RAIL CROSSING SHALL CONSIST OF TWO (2) CHARACTERS AND TWO (2) 16" LINES (FORMING AN X) WHICH ARE PAID FOR UNDER TWO SEPARATE PAY ITEMS. THE TWO (2) 24" TRANSVERSE BANDS WILL BE PAID FOR UNDER A SEPARATE PAY ITEM. REFER TO ROADWAY STANDARD DRAWING 1205.11 FOR ADDITIONAL PAVEMENT MARKING GUIDANCE.

4/6/2015
P:\Projects-U\U3308\Traffic\Signing\CADD\PM\U-3308_PMP-1.dgn
Users\obrn

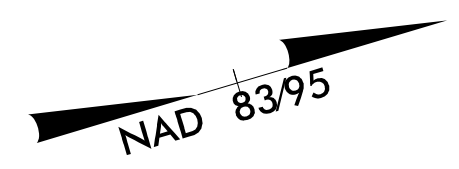



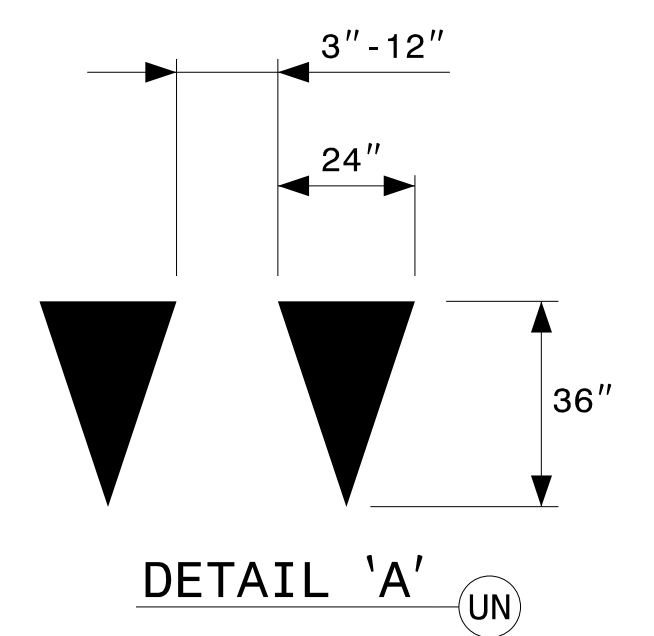
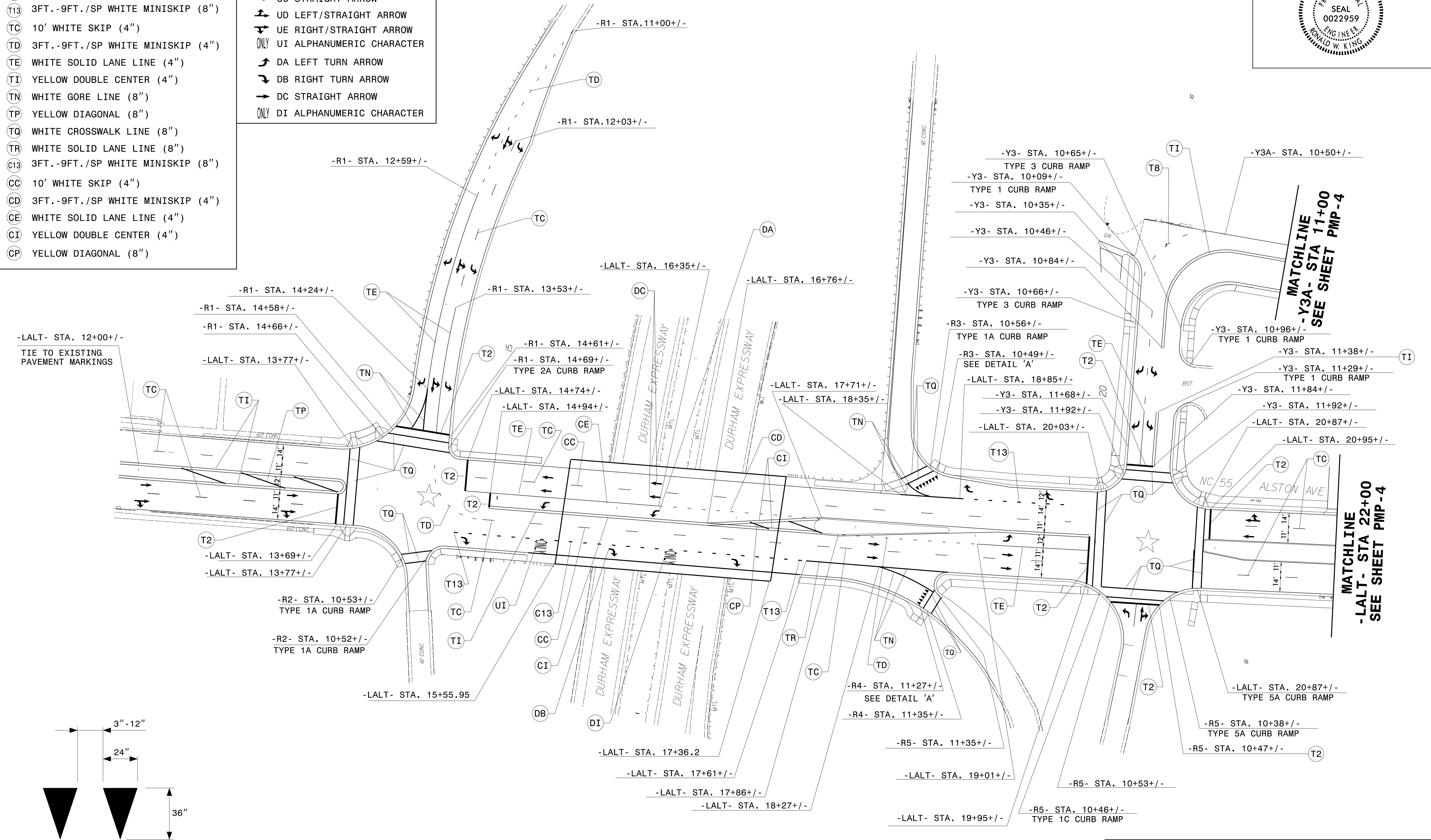

SYMBOL AND PAVEMENT MARKING LEGEND

- | | |
|--|--------------------------------|
| THERMOPLASTIC | |
| (T2) WHITE STOPBAR (24") | ↖ UA LEFT TURN ARROW |
| (T8) 2FT.-6FT./SP WHITE MINISKIP (4") | ↘ UB RIGHT TURN ARROW |
| (T13) 3FT.-9FT./SP WHITE MINISKIP (8") | → UC STRAIGHT ARROW |
| (TC) 10' WHITE SKIP (4") | ↖ UD LEFT/STRAIGHT ARROW |
| (TD) 3FT.-9FT./SP WHITE MINISKIP (4") | ↘ UE RIGHT/STRAIGHT ARROW |
| (TE) WHITE SOLID LANE LINE (4") | ONLY UI ALPHANUMERIC CHARACTER |
| (TI) YELLOW DOUBLE CENTER (4") | ↖ DA LEFT TURN ARROW |
| (TN) WHITE GORE LINE (8") | ↘ DB RIGHT TURN ARROW |
| (TP) YELLOW DIAGONAL (8") | → DC STRAIGHT ARROW |
| (TQ) WHITE CROSSWALK LINE (8") | ONLY DI ALPHANUMERIC CHARACTER |
| (TR) WHITE SOLID LANE LINE (8") | |
| (C13) 3FT.-9FT./SP WHITE MINISKIP (8") | |
| (CC) 10' WHITE SKIP (4") | |
| (CD) 3FT.-9FT./SP WHITE MINISKIP (4") | |
| (CE) WHITE SOLID LANE LINE (4") | |
| (CI) YELLOW DOUBLE CENTER (4") | |
| (CP) YELLOW DIAGONAL (8") | |

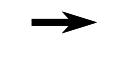

PAVEMENT MARKING DETAIL

4/6/2015
 P:\Projects\U-3308\Traffic\Signing\CADD\PMU-U-3308_PMP-3.dgn
 Jsears:obn

SYMBOL AND PAVEMENT MARKING LEGEND	
THERMOPLASTIC	
(T2)	WHITE STOPBAR (24")
(TB)	YELLOW EDGE LINE (4")
(TC)	10' WHITE SKIP (4")
(TD)	3FT. -9FT./SP WHITE MINISKIP (4")
(TE)	WHITE SOLID LANE LINE (4")
(TI)	YELLOW DOUBLE CENTER (4")
(TP)	YELLOW DIAGONAL (8")
(TQ)	WHITE CROSSWALK LINE (8")
 UA LEFT TURN ARROW  UB RIGHT TURN ARROW  UC STRAIGHT ARROW  UE RIGHT/STRAIGHT ARROW	

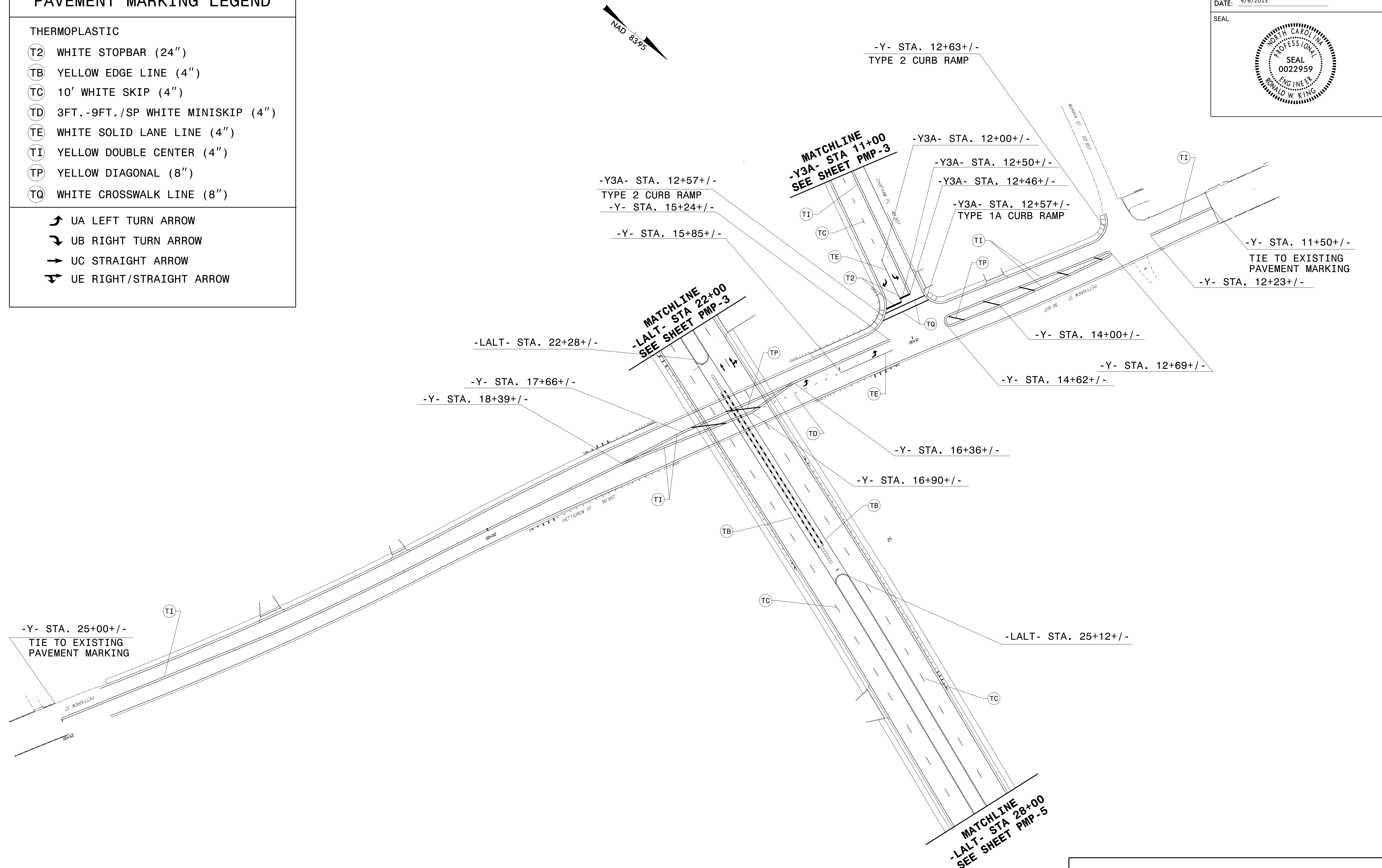

4/6/2015
 P:\Projects-U\U3308-Traffic\Signing\CADD\PMU-U-3308-PMP-4.dgn
 Jserri@hns

PAVEMENT MARKING DETAIL

SYMBOL AND PAVEMENT MARKING LEGEND	
THERMOPLASTIC	
T2	WHITE STOPBAR (24")
TI3	3FT.-9FT./SP WHITE MINISKIP (8")
TA	WHITE EDGELINE (4")
TC	10' WHITE SKIP (4")
TD	3FT.-9FT./SP WHITE MINISKIP (4")
TE	WHITE SOLID LANE LINE (4")
TI	YELLOW DOUBLE CENTER (4")
TO	WHITE CROSSWALK LINE (8")
TR	WHITE SOLID LANE LINE (8")
TL	WHITE SOLID LANE LINE (6")
UA LEFT TURN ARROW UB RIGHT TURN ARROW UC STRAIGHT ARROW UE RIGHT/STRAIGHT ARROW ONLY UI ALPHANUMERIC CHARACTER	

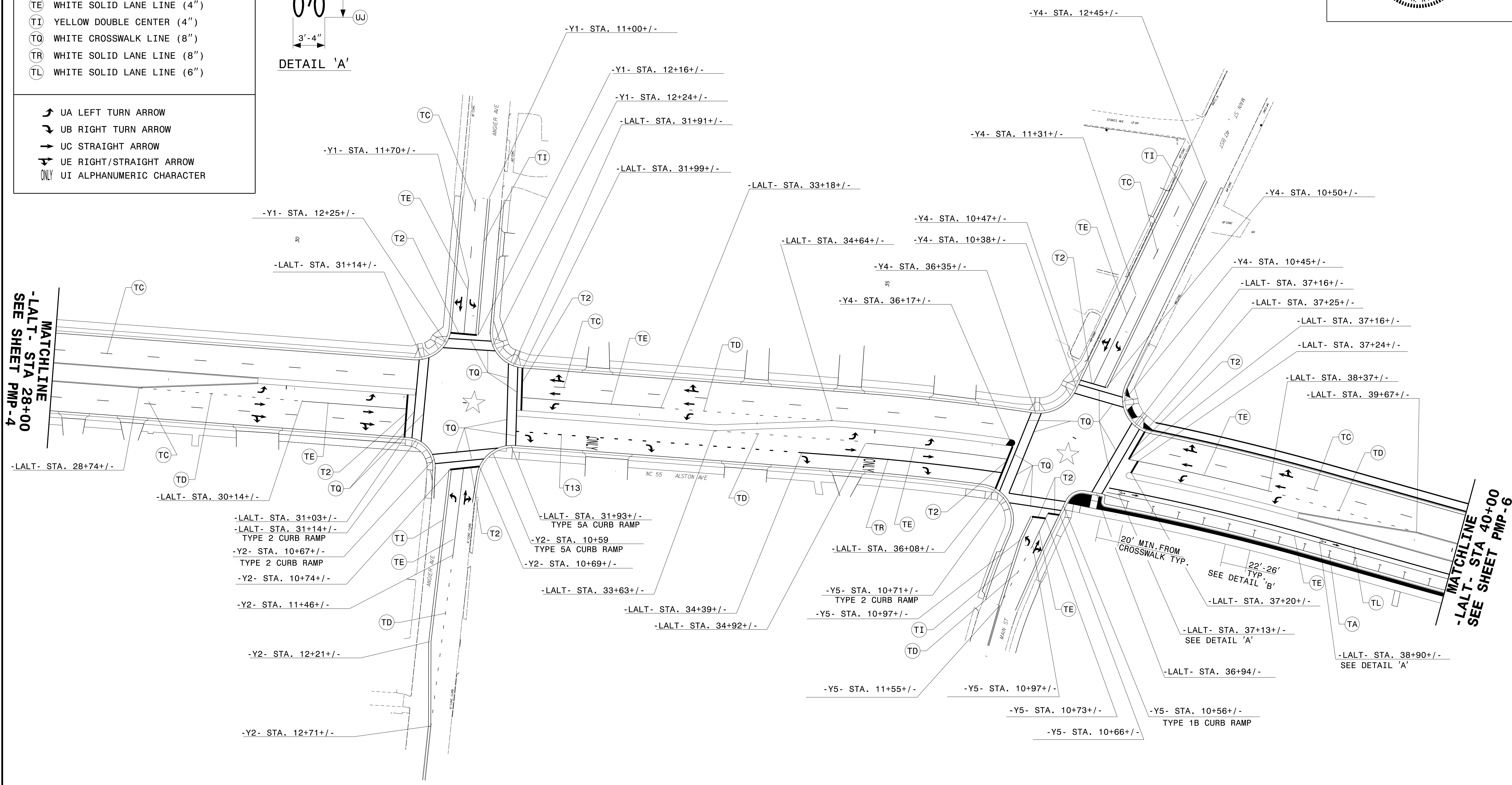
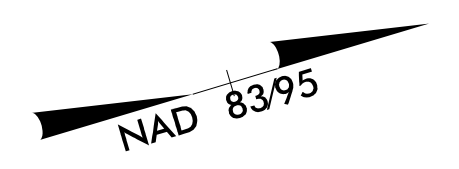
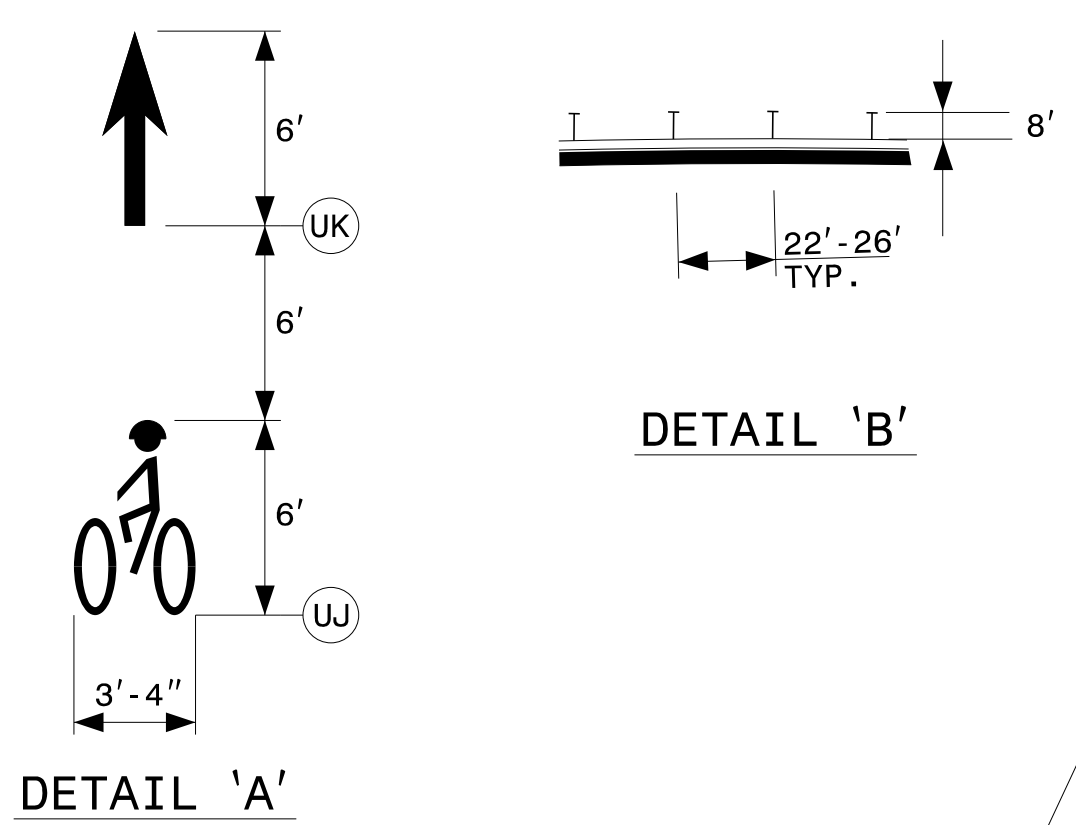

MATCHLINE
-LALT- STA 28+00
SEE SHEET PMP-4

MATCHLINE
-LALT- STA 40+00
SEE SHEET PMP-6

4/6/2015
P:\Projects\U-3308\Traffic\Signing\CADD\VPMP-U-3308_PMP_5.dgn
jserfs@hbs

PAVEMENT MARKING DETAIL

SYMBOL AND PAVEMENT MARKING LEGEND

- THERMOPLASTIC**
- (T2) WHITE STOPBAR (24")
 - (T8) 2FT.-6FT./SP WHITE MINISKIP (4")
 - (T11) 2FT.-6FT./SP WHITE MINISKIP (6")
 - (TA) WHITE EDGELINE (4")
 - (TC) 10' WHITE SKIP (4")
 - (TD) 3FT.-9FT./SP WHITE MINISKIP (4")
 - (TE) WHITE SOLID LANE LINE (4")
 - (TI) YELLOW DOUBLE CENTER (4")
 - (TL) WHITE SOLID LANE LINE (6")
 - (TQ) WHITE CROSSWALK LINE (8")

- ↶ UA LEFT TURN ARROW
- ↷ UB RIGHT TURN ARROW
- UC STRAIGHT ARROW

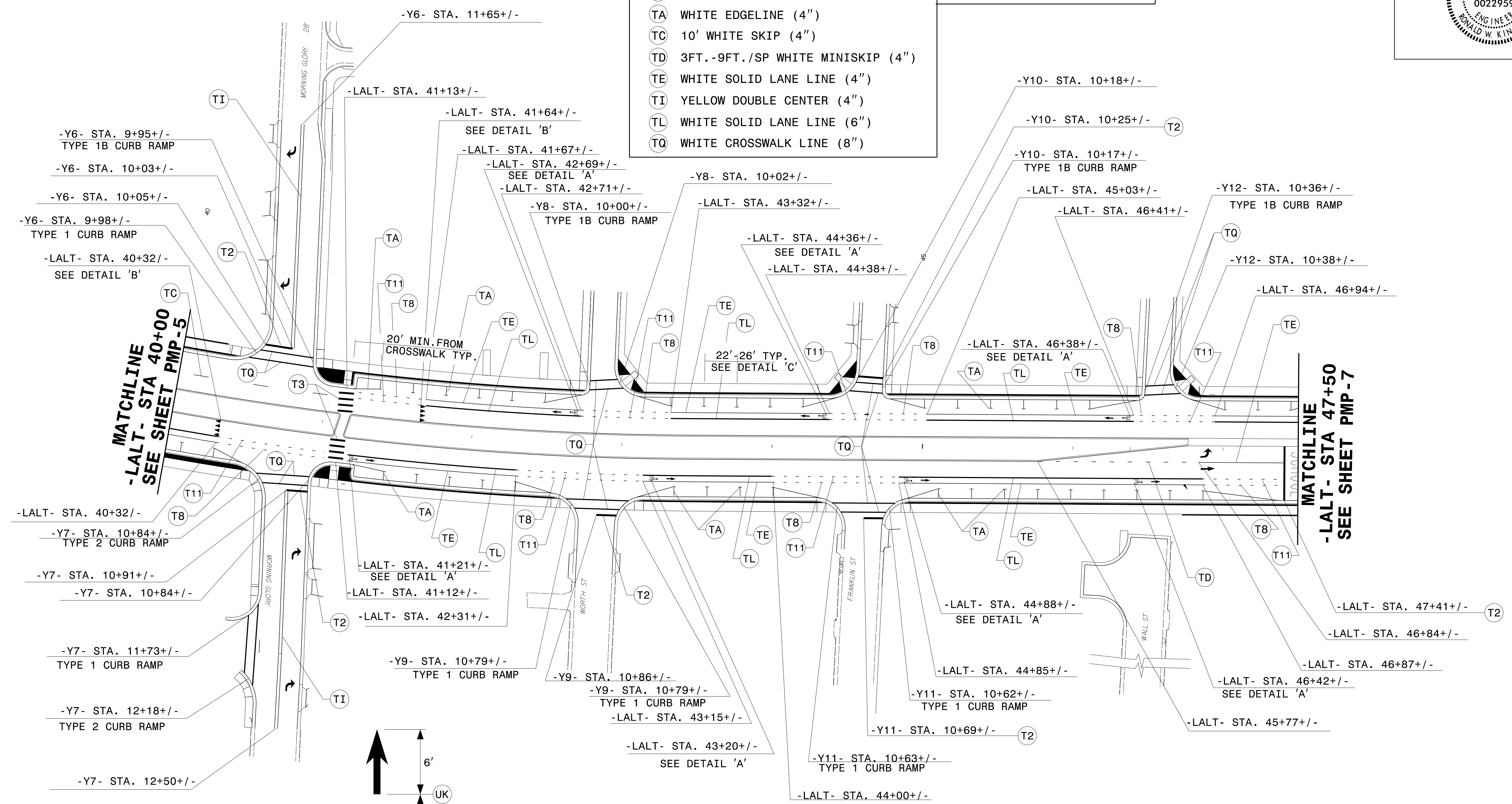
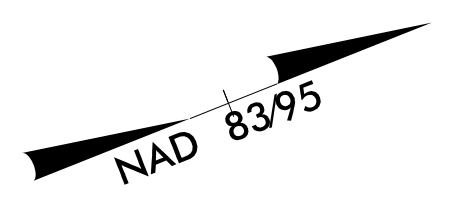

MATCHLINE
-LALT- STA 40+00
SEE SHEET PMP-5

MATCHLINE
-LALT- STA 47+50
SEE SHEET PMP-7

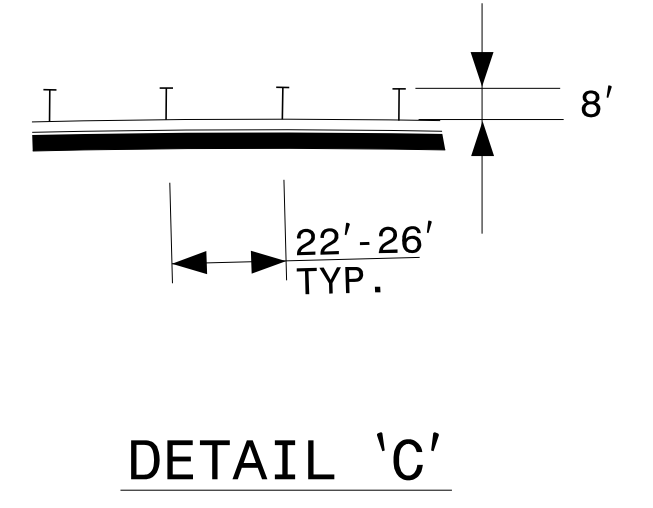
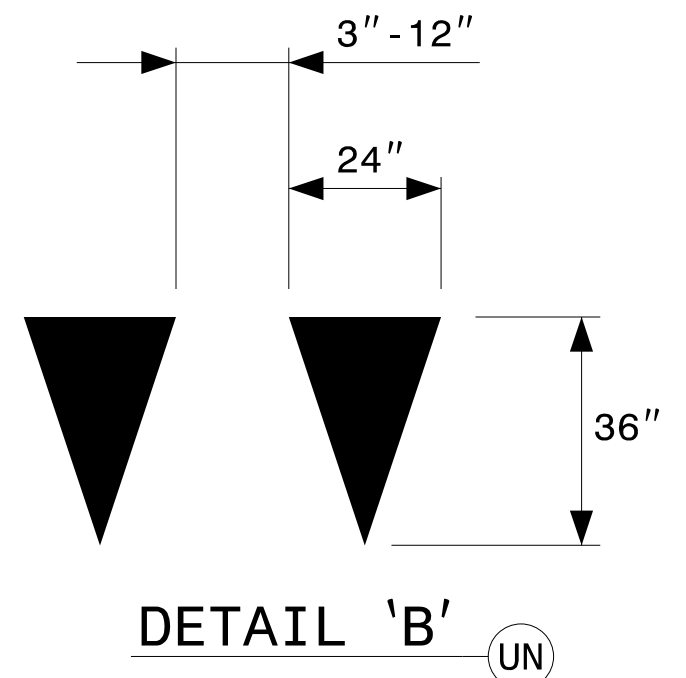
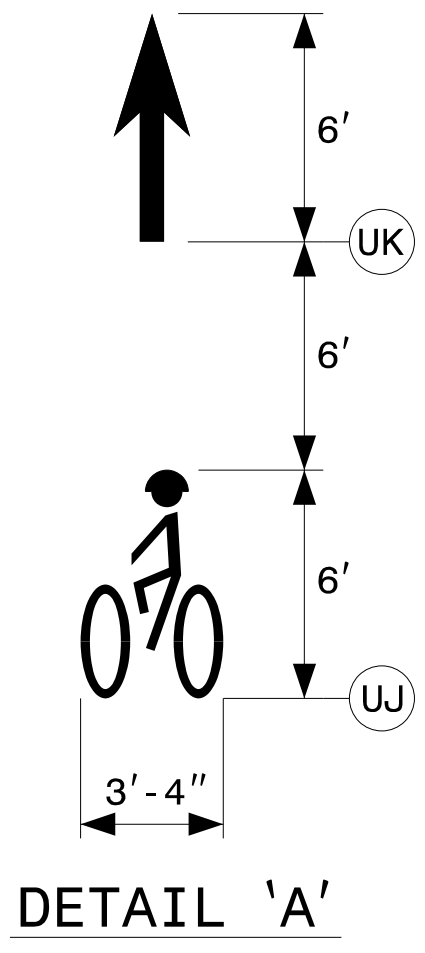

PAVEMENT MARKING DETAIL

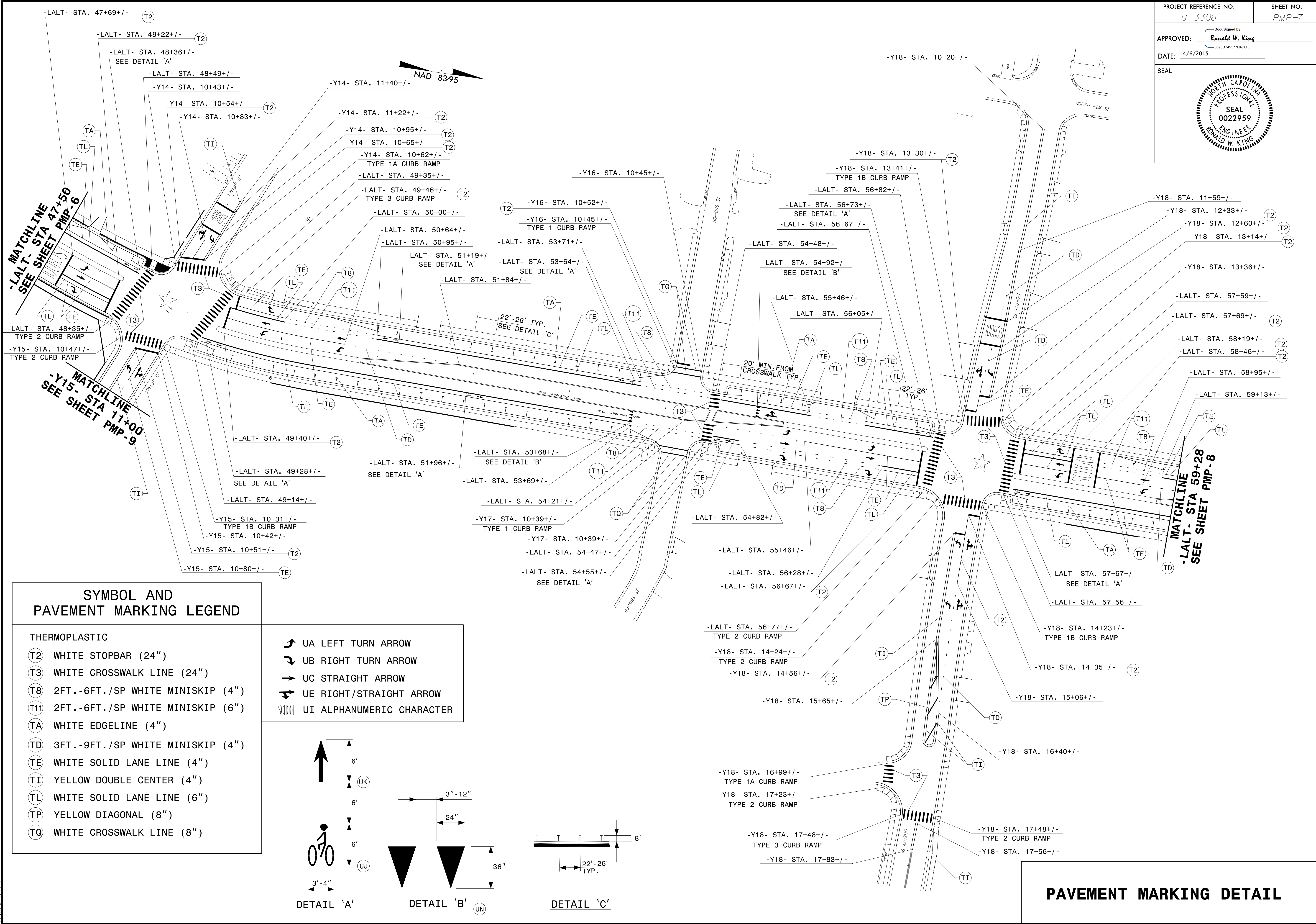

SYMBOL AND PAVEMENT MARKING LEGEND

- THERMOPLASTIC**
- (T2) WHITE STOPBAR (24")
 - (T3) WHITE CROSSWALK LINE (24")
 - (T8) 2FT.-6FT./SP WHITE MINISKIP (4")
 - (T11) 2FT.-6FT./SP WHITE MINISKIP (6")
 - (TA) WHITE EDGELINE (4")
 - (TD) 3FT.-9FT./SP WHITE MINISKIP (4")
 - (TE) WHITE SOLID LANE LINE (4")
 - (TI) YELLOW DOUBLE CENTER (4")
 - (TL) WHITE SOLID LANE LINE (6")
 - (TP) YELLOW DIAGONAL (8")
 - (TQ) WHITE CROSSWALK LINE (8")

- ↖ UA LEFT TURN ARROW
- ↗ UB RIGHT TURN ARROW
- UC STRAIGHT ARROW
- ↘ UE RIGHT/STRAIGHT ARROW
- SCHOOL UI ALPHANUMERIC CHARACTER

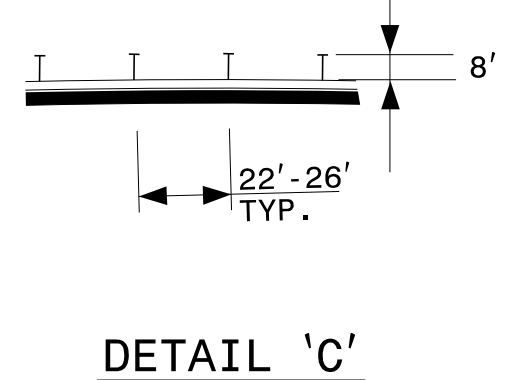
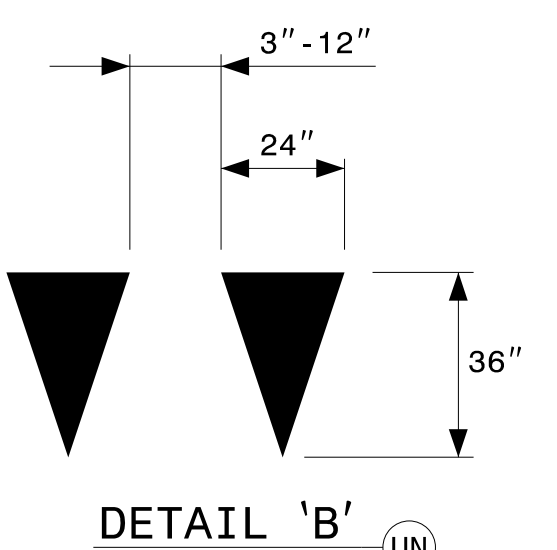
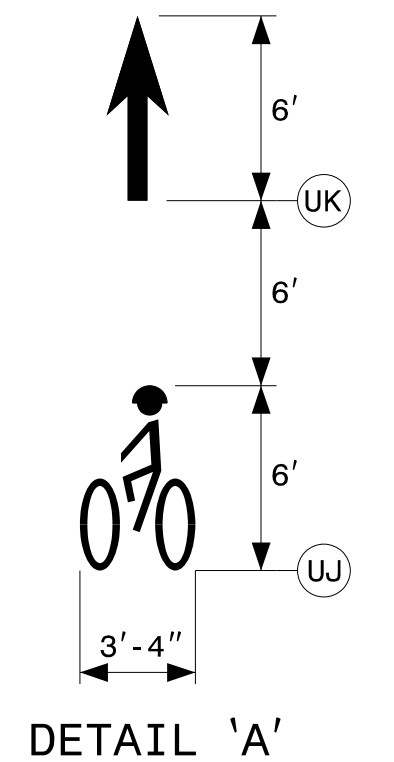

PAVEMENT MARKING DETAIL

4/6/2015 P:\Projects\U-3308-Traffic\Signing\CADD\VPMP-U-3308-PMP-7.dgn



NAD 8395

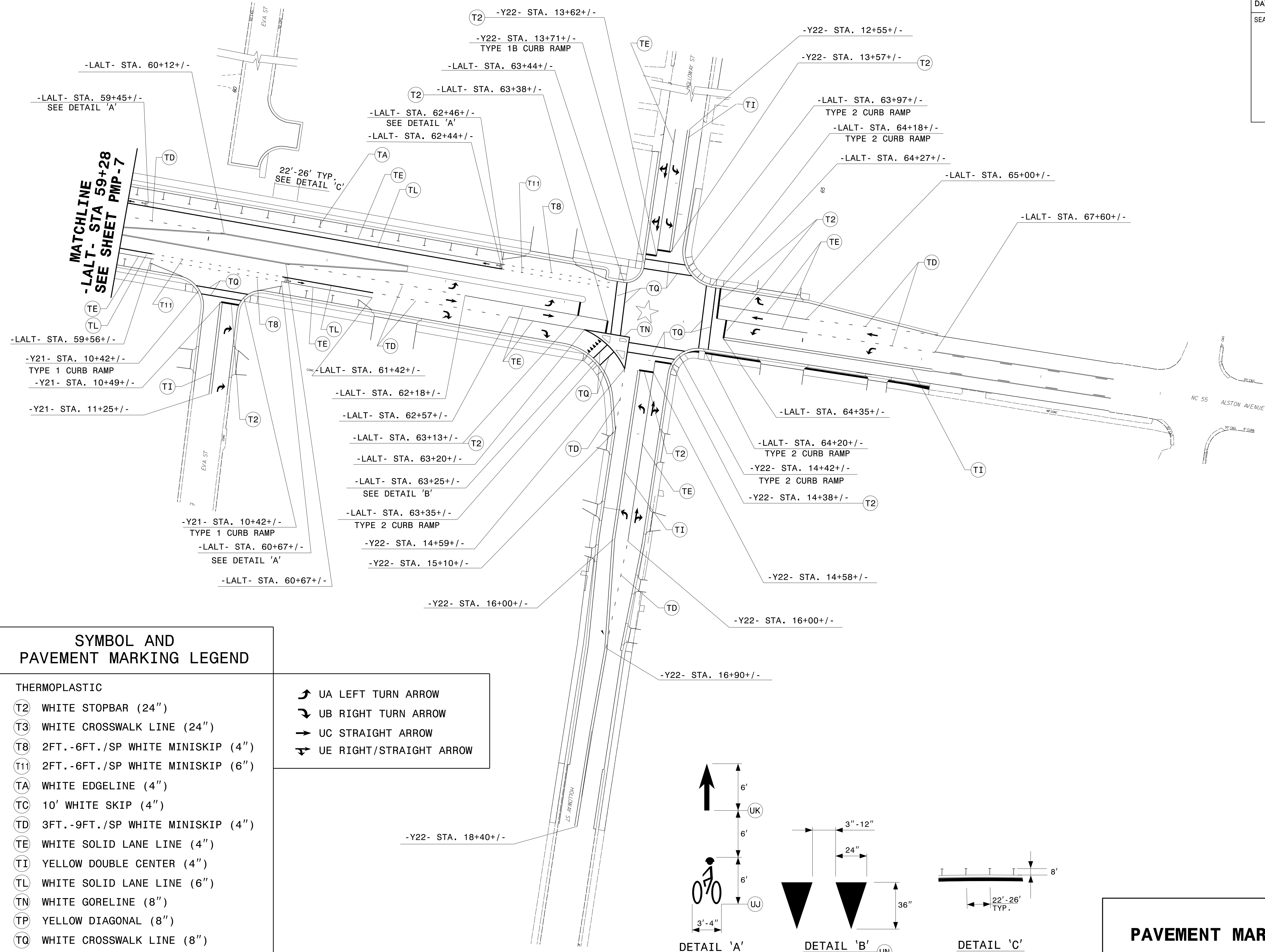

SYMBOL AND PAVEMENT MARKING LEGEND

- THERMOPLASTIC**
- (T2) WHITE STOPBAR (24")
 - (T3) WHITE CROSSWALK LINE (24")
 - (T8) 2FT.-6FT./SP WHITE MINISKIP (4")
 - (T11) 2FT.-6FT./SP WHITE MINISKIP (6")
 - (TA) WHITE EDGELINE (4")
 - (TC) 10' WHITE SKIP (4")
 - (TD) 3FT.-9FT./SP WHITE MINISKIP (4")
 - (TE) WHITE SOLID LANE LINE (4")
 - (TI) YELLOW DOUBLE CENTER (4")
 - (TL) WHITE SOLID LANE LINE (6")
 - (TN) WHITE GORELINE (8")
 - (TP) YELLOW DIAGONAL (8")
 - (TQ) WHITE CROSSWALK LINE (8")

- ↶ UA LEFT TURN ARROW
- ↷ UB RIGHT TURN ARROW
- UC STRAIGHT ARROW
- ↷ UE RIGHT/STRAIGHT ARROW

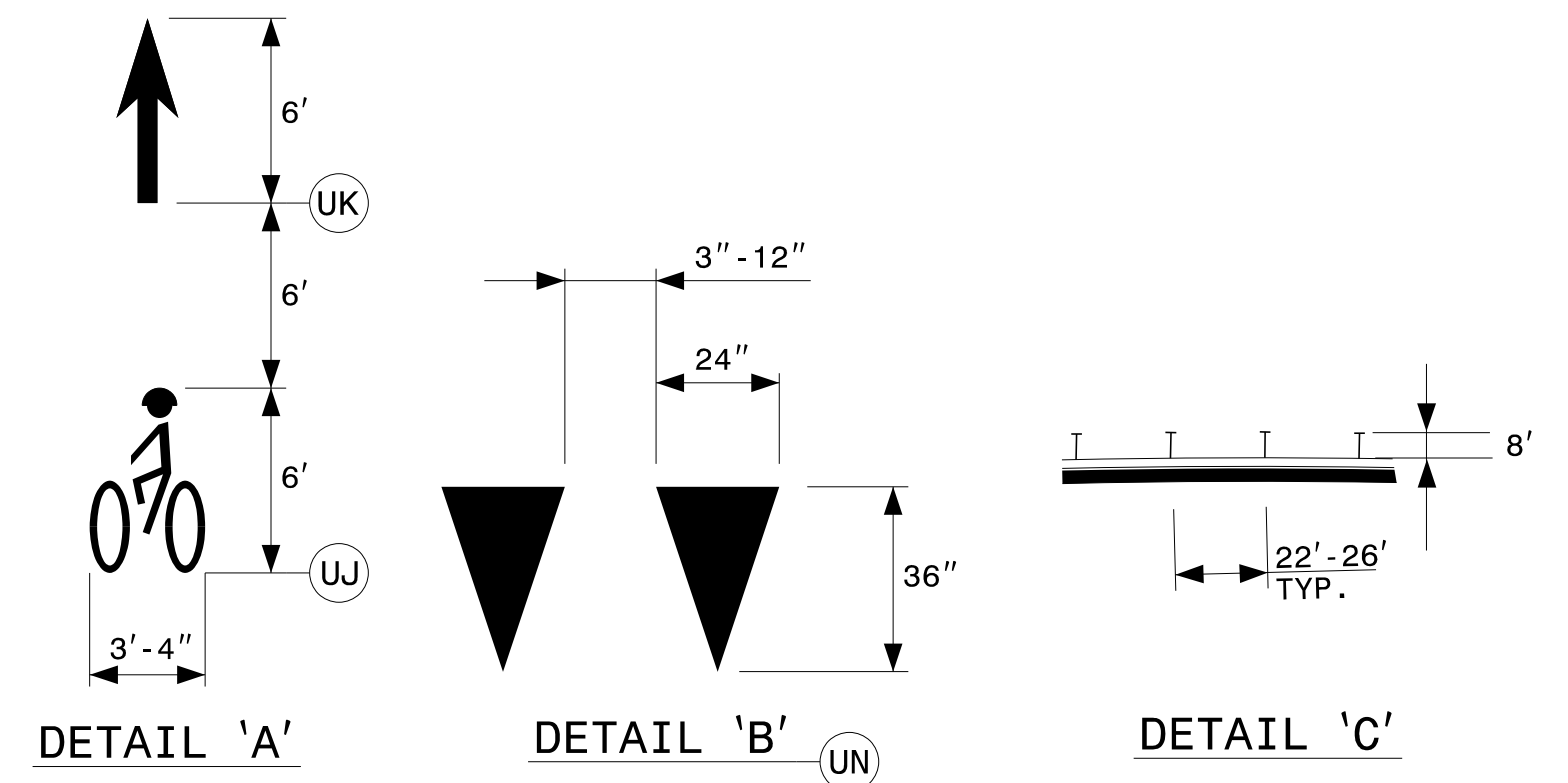

PAVEMENT MARKING DETAIL

4/6/2015 P:\Projects-U\U3308-Traffic\Signing\CADD\PMU-U-3308_PMP-8.dgn
 jsestebans

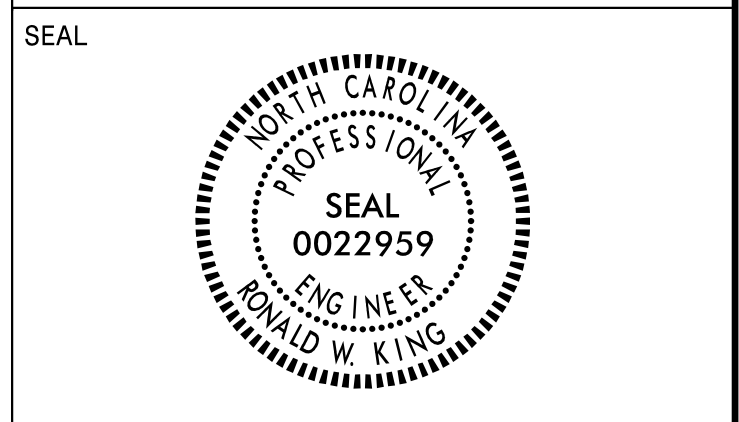

SYMBOL AND PAVEMENT MARKING LEGEND

- THERMOPLASTIC
- (T2) WHITE STOPBAR (24")
 - (T3) WHITE CROSSWALK LINE (24")
 - (TD) 3FT.-9FT./SP WHITE MINISKIP (4")
 - (TE) WHITE SOLID LANE LINE (4")
 - (TI) YELLOW DOUBLE CENTER (4")

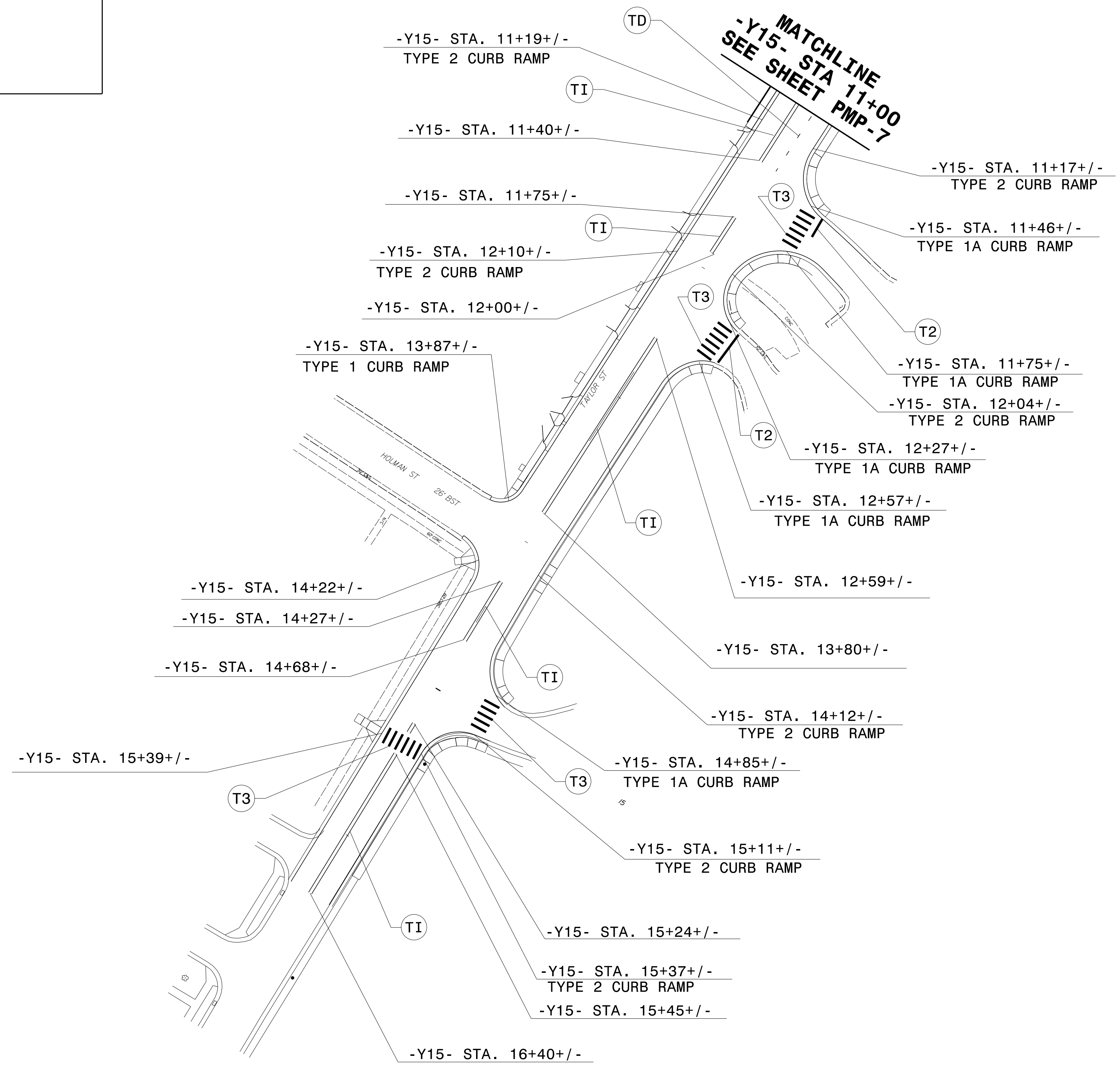
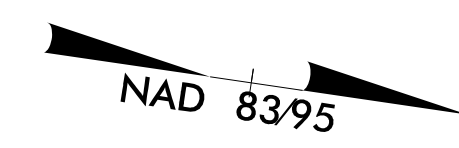

4/6/2015
 P:\Projects-U\U3308-Traffic\Signing\CADD\PMU-U-3308-PMP-9.dgn
 Jseris:rbns

PAVEMENT MARKING DETAIL