

**NOTES:**  
 ALL REINFORCING STEEL TO BE EPOXY COATED.  
 FOR "DETAIL B", SEE "SHEET 1 OF 2".  
 FOR "SECTION A-A", SEE "CONCRETE DECK DETAILS" SHEET 1 OF 2.  
 FOR "SECTION B-B", SEE "CONCRETE DECK DETAILS" SHEET 1 OF 2.  
 FOR "SECTION C-C", SEE "CONCRETE DECK DETAILS" SHEET 1 OF 2.

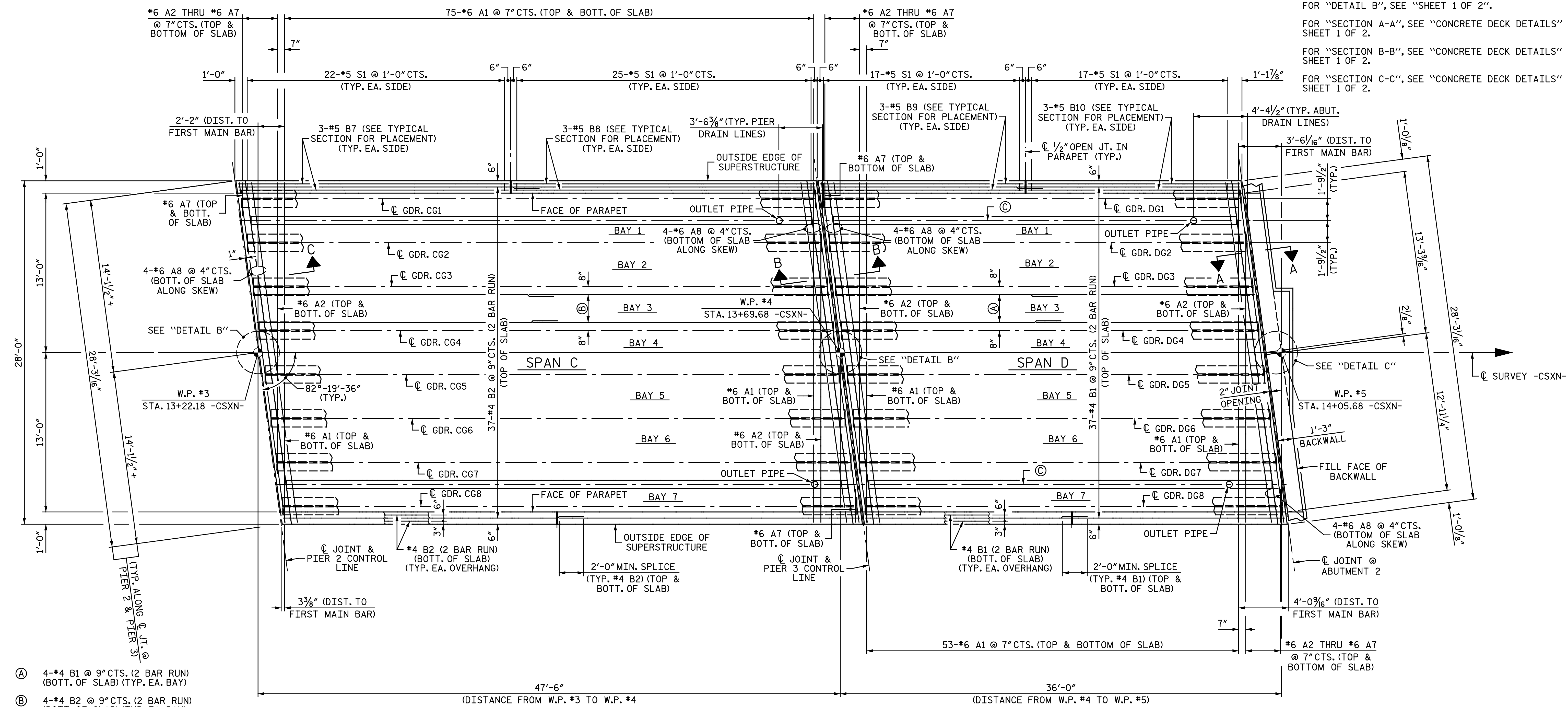

**PLAN OF SPANS**

PROJECT NO. U-3308  
 DURHAM COUNTY  
 STATION: 24+55.20 -LALT-  
13+22.18 -CSXN-  
 SHEET 2 OF 2

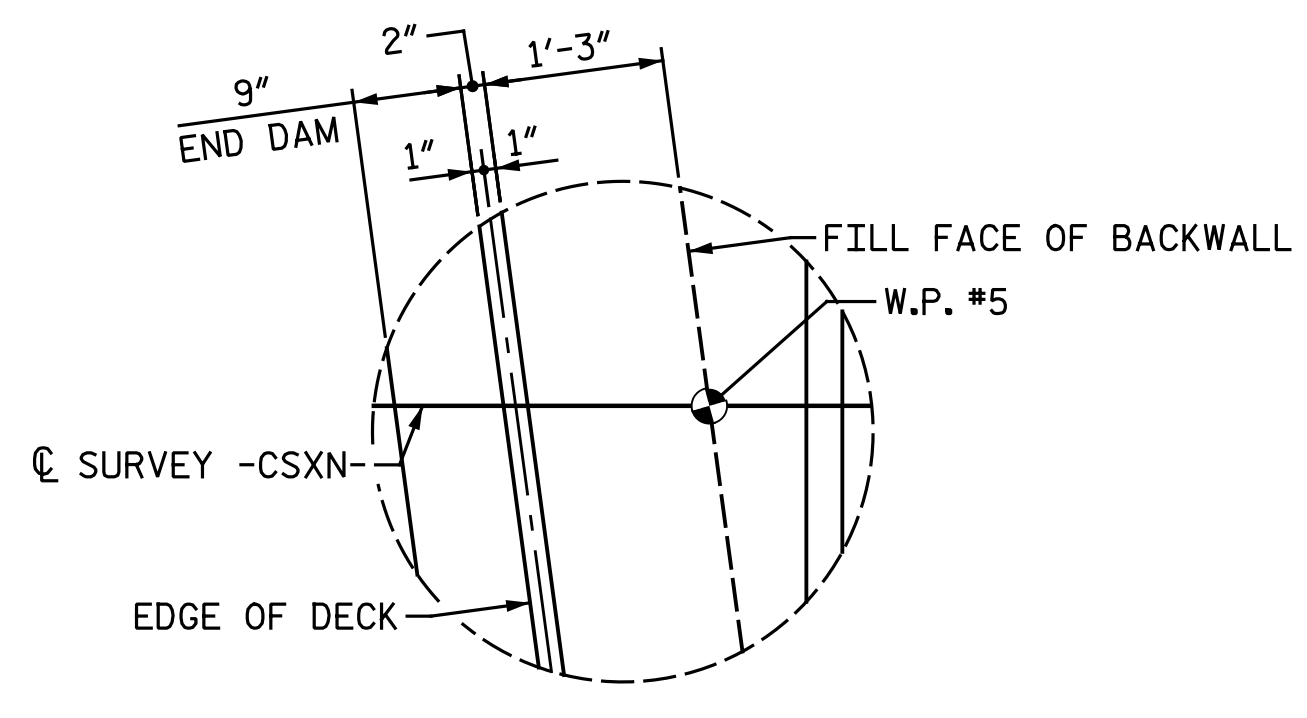

**DETAIL C**

- Ⓐ 4-#4 B1 @ 9" CTS. (2 BAR RUN) (BOTT. OF SLAB) (TYP. EA. BAY)
- Ⓑ 4-#4 B2 @ 9" CTS. (2 BAR RUN) (BOTT. OF SLAB) (TYP. EA. BAY)
- Ⓒ 12 GAUGE STEEL PAN (GALVANIZED & BITUMINOUS COATED)

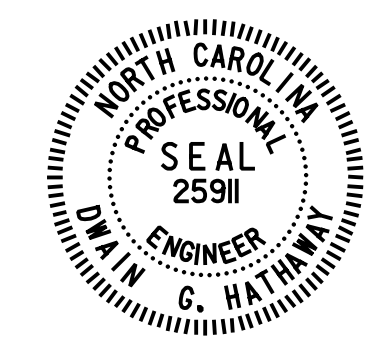

5/3/2016

**Michael Baker INTERNATIONAL**

Michael Baker Engineering  
 8000 Regency Parkway, Suite 600  
 Cary, North Carolina 27618  
 NC License No.: F-1084

STATE OF NORTH CAROLINA  
 DEPARTMENT OF TRANSPORTATION  
 RALEIGH  
 SUPERSTRUCTURE  
 PLAN OF SPANS  
 SPANS C & D

REVISIONS						SHEET NO.
NO.	BY:	DATE:	NO.	BY:	DATE:	S4-14
1			3			TOTAL SHEETS
2			4			68

5/3/2016 9:37:04 AM  
 File Name: Y:\Projects\NCDOT\U-3308\Structures\Drawings\Final\404\_014\_U3308\_SML\_502.dgn  
 omayhew

DRAWN BY: M. D. MAYHEW DATE: 1-9-14  
 CHECKED BY: S. A. DENNEY DATE: 2-25-14