

PLAN

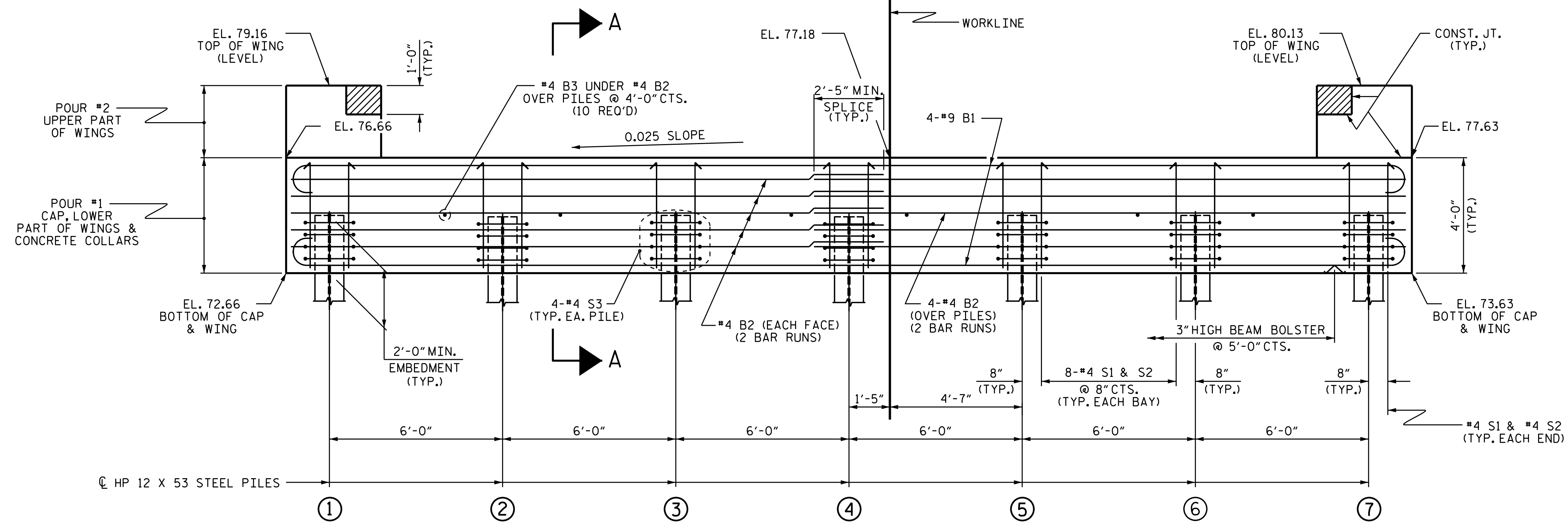

ELEVATION

WINGS NOT SHOWN FOR CLARITY.
 FOR SECTION A-A, SEE SHEET 4 OF 4.
 CONCRETE COLLARS FOR STEEL PILES NOT SHOWN IN PLAN AND ELEVATION VIEWS FOR CLARITY.
 SEE "CORROSION PROTECTION FOR STEEL PILES DETAIL", SHEET 4 OF 4.

NOTES

- STIRRUPS IN CAP MAY BE SHIFTED AS NECESSARY TO CLEAR DOWELS.
- THE CONCRETE IN THE SHADED AREA OF THE WING SHALL BE POURED AFTER THE VERTICAL CONCRETE BARRIER RAIL IS CAST IF SLIP FORMING IS USED.
- FOR PILE SPLICE DETAILS, SEE SHEET 4 OF 4.
- FOR WING DETAILS, SEE SHEET 3 OF 4.

TOP OF PILE ELEVATIONS	
①	74.68
②	74.83
③	74.98
④	75.13
⑤	75.27
⑥	75.42
⑦	75.59

PROJECT NO. B-5313
WILSON COUNTY
 STATION: 15+45.50 -L-
 SHEET 2 OF 4

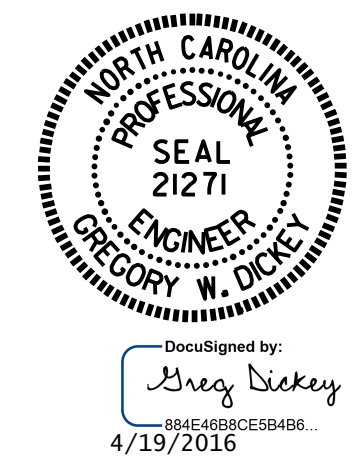

STATE OF NORTH CAROLINA
 DEPARTMENT OF TRANSPORTATION
 RALEIGH

SUBSTRUCTURE
 END BENT No. 2

ASSEMBLED BY : REZA KOUCHEKI	DATE : 7/1/15
CHECKED BY : W.F.PARKER	DATE : 11/15
DRAWN BY : WJH	12/11
CHECKED BY : AAC	12/11
REV. 4/15	MAA/TMG

DOCUMENT NOT CONSIDERED FINAL UNLESS ALL SIGNATURES COMPLETED

REVISIONS						SHEET NO.
NO.	BY:	DATE:	NO.	BY:	DATE:	S-12
1			3			TOTAL SHEETS 19
2			4			