

PLAN @ END BENT 1
 PLAN @ END BENT 2
 DIMENSIONS SHOWN ARE TYPICAL FOR BOTH APPROACH SLABS

NOTES

APPROACH SLAB SHALL NOT BE CONSTRUCTED PRIOR TO COMPLETION OF THE BRIDGE DECK.
 FOR REINFORCED BRIDGE APPROACH FILL FABRIC WALL INCLUDING GEOTEXTILE, IMPERMEABLE GEOMEMBRANE, 4" Ø DRAINAGE PIPE, #78M STONE, WELDED WIRE FORM, AND SELECT MATERIAL, SEE ROADWAY PLANS.
 AREA BETWEEN THE WINGWALL AND APPROACH SLAB SHALL BE GRADED TO DRAIN THE WATER AWAY FROM THE FILL FACE OF THE BRIDGE AND SHALL BE PAVED. SEE ROADWAY PLANS.
 THE JOINT OPENING AT THE APPROACH SLAB/DECK INTERFACE SHALL BE SAWS NO MORE THAN 12 HOURS AFTER THE APPROACH SLAB IS CAST. THE JOINT SHALL BE CLEANED OF ALL DEBRIS BEFORE THE SEALANT IS APPLIED. THE JOINT SEALER MATERIAL SHALL CONFORM TO THE REQUIREMENTS OF SECTION 1028-3 OF THE STANDARD SPECIFICATIONS.

| BILL OF MATERIAL | | | | | |
|----------------------------------|-----|------|------|--------|--------|
| FOR ONE APPROACH SLAB (2 REQ'D) | | | | | |
| BAR | NO. | SIZE | TYPE | LENGTH | WEIGHT |
| * A1 | 52 | #4 | STR | 18'-6" | 643 |
| A2 | 52 | #4 | STR | 18'-5" | 640 |
| * B1 | 70 | #5 | STR | 24'-3" | 1770 |
| B2 | 70 | #6 | STR | 24'-8" | 2593 |
| REINFORCING STEEL | | | | LBS. | 3,233 |
| * EPOXY COATED REINFORCING STEEL | | | | LBS. | 2,413 |
| CLASS AA CONCRETE | | | | C. Y. | 38.2 |

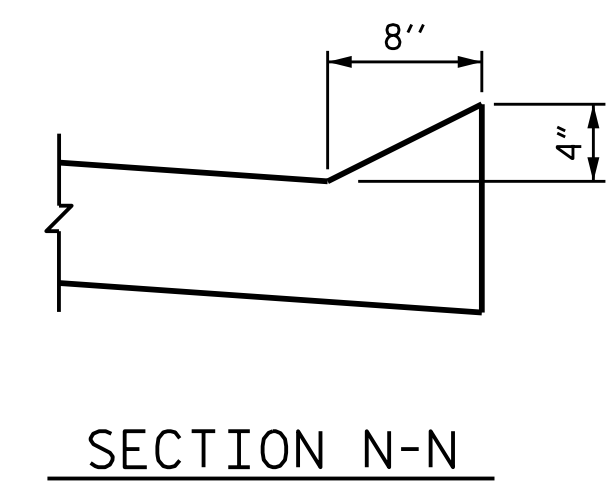
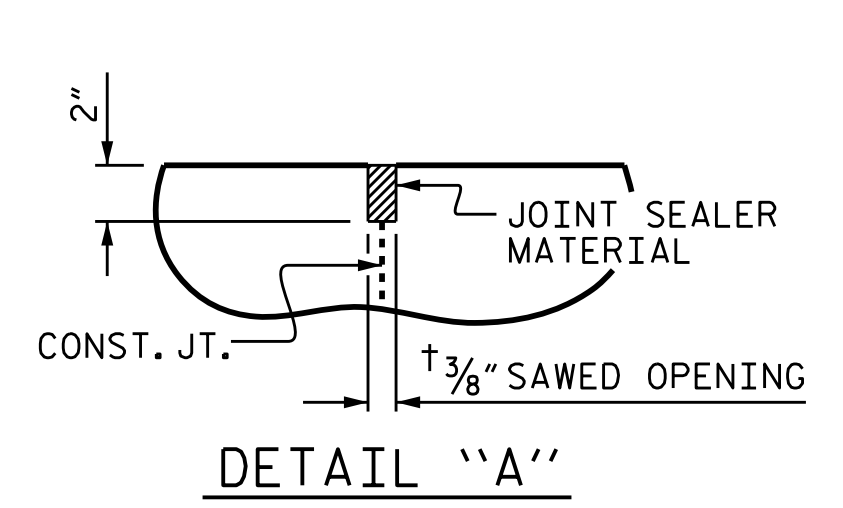
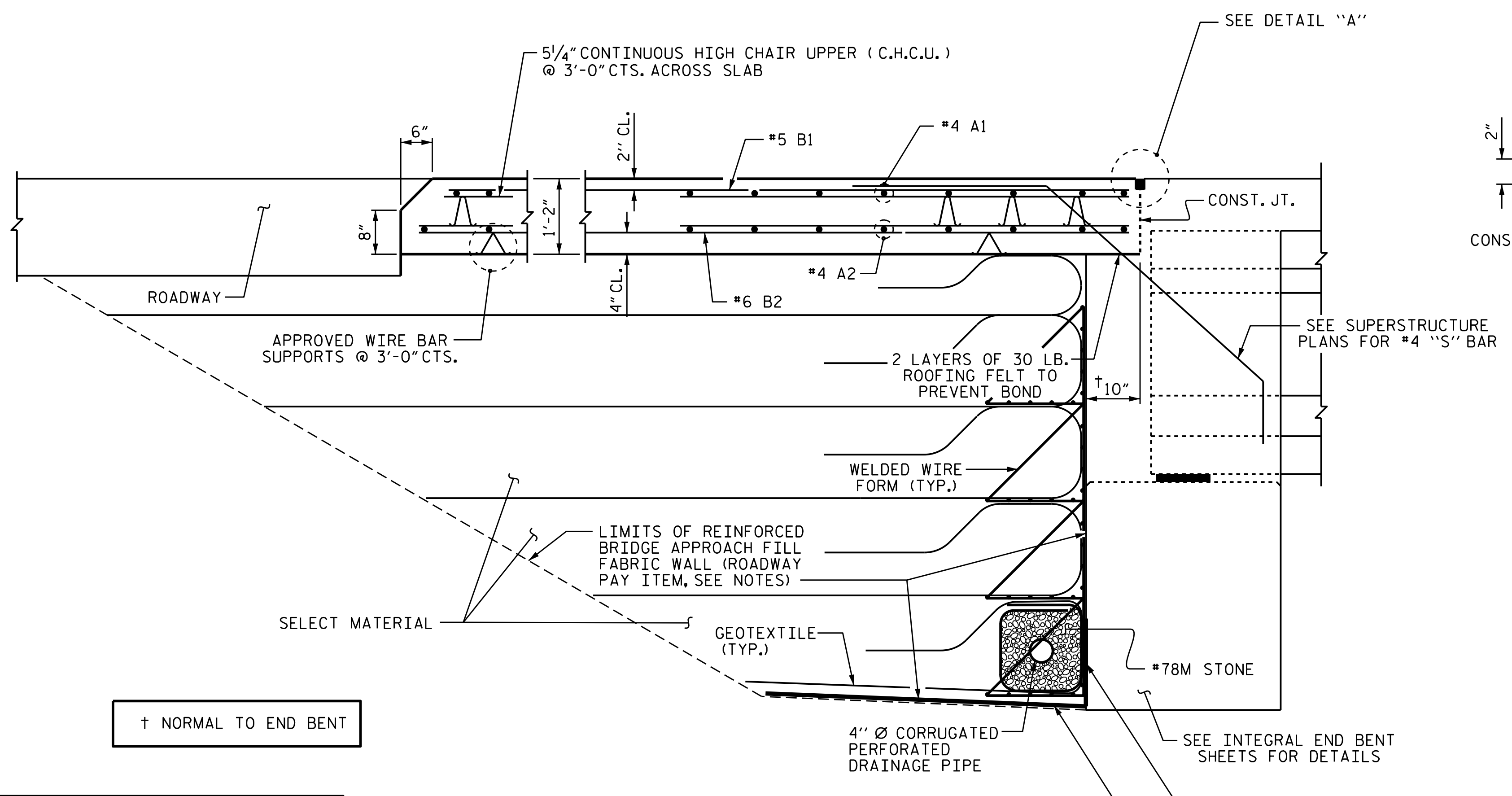

SECTION THROUGH SLAB

PROJECT NO. B-5142
IREDELL COUNTY
 STATION: 22+06.00 -L-

SHEET 1 OF 2

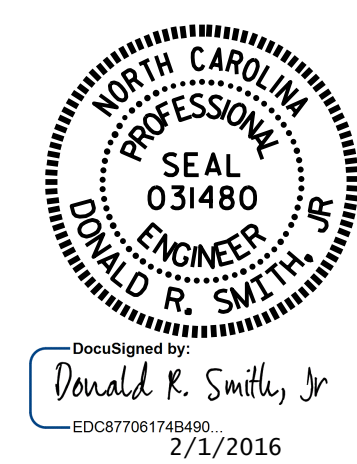

STATE OF NORTH CAROLINA
 DEPARTMENT OF TRANSPORTATION
 RALEIGH
 STANDARD
 BRIDGE APPROACH SLAB
 FOR INTEGRAL ABUTMENT

| | |
|----------------------------|----------------------|
| ASSEMBLED BY : K. D. LAYNE | DATE : 4-30-15 |
| CHECKED BY : H.P. KIM | DATE : 5-14-15 |
| DRAWN BY : TLA 10/05 | REV. 10/1/11 MAA/GM |
| CHECKED BY : GM 5/06 | REV. 12/21/11 MAA/GM |
| | REV. 6/13 MAA/GM |

DOCUMENT NOT CONSIDERED FINAL UNLESS ALL SIGNATURES COMPLETED

| REVISIONS | | | | | | SHEET NO. |
|-----------|-----|-------|-----|-----|-------|--------------|
| NO. | BY: | DATE: | NO. | BY: | DATE: | S-37 |
| 1 | | | 3 | | | TOTAL SHEETS |
| 2 | | | 4 | | | 38 |