

TYPICAL SECTION NO. 2
 TO BE USED ON MAPS: 4, 7, 8
 MAP 4: STA. 10+00 TO STA. 17+37
 MAP 7: STA. 16+27 TO STA. 17+87
 MAP 8: STA. 10+64 TO STA. 20+64

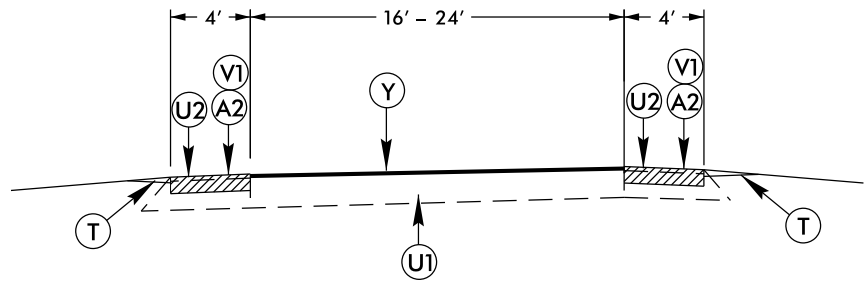

TYPICAL SECTION NO. 5
 TO BE USED ON MAPS 5, 7, 11
 MAP 5: STA. 9+70 TO STA. 18+34
 MAP 7: STA. 10+00 TO STA. 16+27
 MAP 11: STA. 10+00 TO STA. 17+18

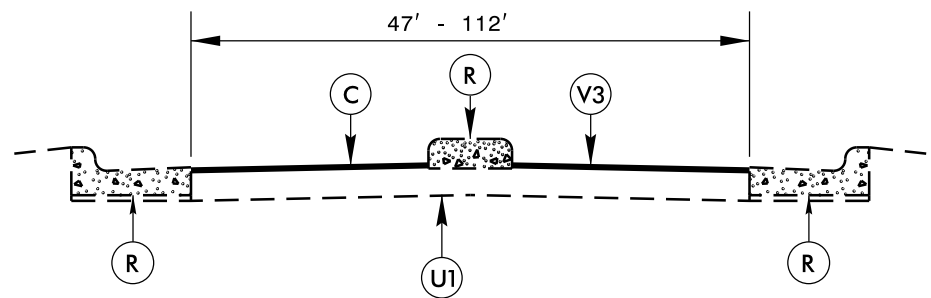

TYPICAL SECTION NO. 3
 TO BE USED ON MAPS 4, 7
 MAP 4: STA. 17+37 TO STA. 17+57
 MAP 7: STA. 17+87 TO STA. 18+37

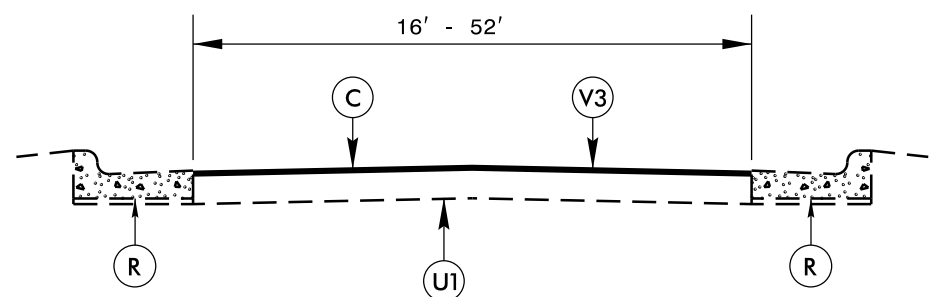

TYPICAL SECTION NO. 4
 TO BE USED ON MAPS 5, 8
 MAP 5: STA. 9+18 TO STA. 9+70
 MAP 8: STA. 10+00 TO STA. 10+64

**PATCHING DETAIL FOR SHOULDER DRAIN
 (Pavement Repair)**

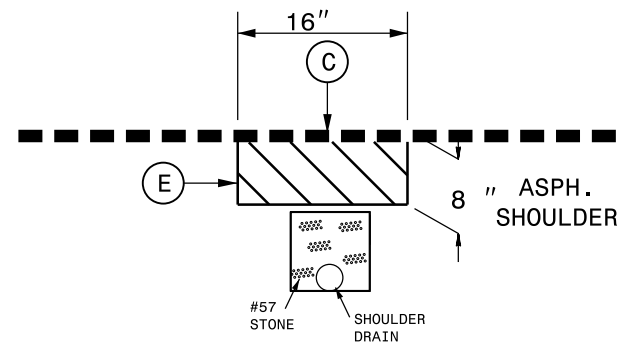

REMOVE EXISTING ASPHALT PAVEMENT 8" IN DEPTH AND FILL WITH 6 1/2" BASE COURSE TYPE B25.0B IN ONE LIFT AND 1 1/2" SURFACE COURSE, TYPE S9.5C AT LOCATIONS AS DIRECTED BY THE ENGINEER.

TO BE USED IN CONJUNCTION WITH MAPS 1 AND 2
 (SEE SHOULDER DRAIN SHEET)

PAVEMENT SCHEDULE	
A1	8" ROLLED COMPACTED CONCRETE (RCC).
A2	8" PORTLAND CEMENT CONCRETE PAVEMENT (PCCP)
C	PROP. APPROX. 1 1/2" ASPHALT CONCRETE SURFACE COURSE, TYPE S9.5C, AT AN AVERAGE RATE OF 168 LBS. PER SQ. YD.
E	PROP. APPROX. 6 1/2" ASPHALT CONCRETE BASE COURSE, TYPE B25.0B, AT AN AVERAGE RATE OF 741 LBS. PER SQ. YD. IN ONE LIFT
F	PROPOSED FOG SEAL TO BE APPLIED TO THE EXISTING ASPHALT SHOULDER
R	EXISTING CONCRETE STRUCTURE
T	SHOULDER RECONSTRUCTION
U1	EXISTING TRAVELWAY
U2	EXISTING PAVED SHOULDER.
V1	8" TRENCHING
V2	MILLED RUMBLE STRIP
V3	1 1/2" MILLING
Y	PROPOSED DIAMOND GRINDING

5/14/99
 13-APR-2016 14:21
 :tsa\division\715738\15821\5738\15789\Gulford Rendolph June 2016\I-5821-I-5738-I-5789 typicals.dgn
 P:\piper\at\csp\28299