

**This electronic collection of documents is provided
for the convenience of the user
and is Not a Certified Document –**

**The documents contained herein were originally issued
and sealed by the individuals whose names and license
numbers appear on each page, on the dates appearing
with their signature on that page.**

**This file or an individual page
shall not be considered a certified document.**

**STATE OF NORTH CAROLINA
DEPARTMENT OF TRANSPORTATION**

PROJECT REFERENCE NO. <i>U-3308</i>	SHEET NO. <i>SIGN-1</i>
APPROVED: <i>Ronald W. King</i> <small>DocuSigned by: 069607A8677C4DC...</small>	
DATE: 4/6/2015	
SEAL 	

**SIGNING PLAN
DURHAM COUNTY**

**LOCATION: NC 55 (ALSTON AVE) FROM NC 147 (I.L."BUCK" DEAN FREEWAY) TO
NORTH OF US 70 BUS /NC 98 (HOLLOWAY ST)**

ROADWAY STANDARD DRAWING

THE FOLLOWING ROADWAY STANDARDS AS APPEAR IN "ROADWAY STANDARD DRAWINGS" - PROJECT SERVICES UNIT - N.C. DEPARTMENT OF TRANSPORTATION - RALEIGH, N.C., DATED JANUARY 2012 ARE APPLICABLE TO THIS PROJECT AND BY REFERENCE HEREBY ARE CONSIDERED A PART OF THESE PLANS:

STD. NO.	TITLE
901.50	ARROWS AND SHIELDS
904.50	MOUNTING OF TYPE 'D', 'E' AND 'F' SIGNS ON 'U' CHANNEL POSTS

GENERAL NOTES

- . SIGNS FURNISHED BY STATE
- . ALL EXISTING SIGNS/SIGN SYSTEM WITHIN THE PROJECT LIMITS SHALL BE REMOVED AND DISPOSED OF UNLESS OTHERWISE NOTED ON PLANS. THE SIGNS TO BE DISPOSED ARE NOT SHOWN ON THE PLAN; HOWEVER THE PAY ITEM/QUANTITY IS INCLUDED IN THE CONTRACT.
- . ALL TYPE 'D' SIGNS SHALL BE MOUNTED ON TWO U-CHANNEL POSTS UNLESS OTHERWISE INDICATED ON THE PLANS.
- . IF REMOVAL OR RELOCATION OF SIGNS ON PRIVATE STREET (NON-STATE MAINTAINED) IS REQUIRED DUE TO CONSTRUCTION, THE CONTRACTOR SHALL INFORM THE ENGINEER. THE WORK WILL BE COMPLETED BY OTHERS.
- . WHEN NOT STATIONED OR DIMENSIONED ON PLANS, ALL 'E' AND 'F' SIGNS SHALL BE FIELD LOCATED BY THE ENGINEER
- . WHEN EXISTING SIGNS ARE REMOVED AND INSTALLED ON NEW SUPPORTS, THE RE-ERECTION SHALL IMMEDIATELY FOLLOW THE REMOVAL.
- . THE BACKGROUND FOR TYPE E & F SIGNS SHALL BE TYPE C REFLECTIVE SHEETING.
- . SEE ROADWAY PLANS FOR GUARD/GUIDE RAIL DETAILS.

SUMMARY OF QUANTITIES

ITEM NO.		ITEM DESCRIPTION	QUANTITY	UNIT
DESC. NO.	SECT. NO.			
4072000000	903	SUPPORTS, 3 LB STEEL U-CHANNEL	2322	L.F.
4096000000	904	SIGN ERECTION, TYPE D	2	EA.
4102000000	904	SIGN ERECTION, TYPE E	141	EA.
4108000000	904	SIGN ERECTION, TYPE F	26	EA.
4155000000	907	DISPOSAL OF SIGN SYSTEM, U-CHANNEL	86	EA.

PROJECT NOTES

1	DISPOSAL OF SIGN SYSTEM, U-CHANNEL
---	------------------------------------

INDEX

SHEET NO.	DESCRIPTION
SIGN-1	TITLE SHEET
SIGN-2	E SHEET
SIGN-3	D & F SHEET
SIGN-4-10	SIGNING PLAN SHEETS

PLAN PREPARED BY: N.C.D.O.T. SIGNING AND DELINEATION UNIT

RENEE B. ROACH, P.E. SIGNING & DELINEATION REGIONAL ENGINEER
STACEY W. JOHNS SIGNING & DELINEATION PROJECT DESIGN ENGINEER

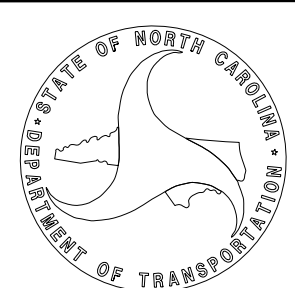

T.I.P.: U-3308

CONTRACT: C203567



401 QUANTITY REQ'D 1

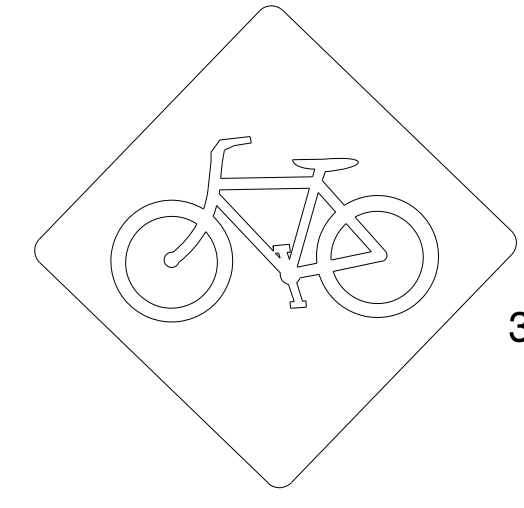

30 x 30
W11-1

ONE "U" POST PER SIGN

406 QUANTITY REQ'D 4



54 X 18
R6-1 (L)

MOUNT BACK TO BACK WITH SIGN 405
IN 2 INSTALLATION

411 QUANTITY REQ'D 2



36 X 36
R1-5R

ONE "U" POST PER SIGN

416 QUANTITY REQ'D 1



24 X 8
R3-17bP

MOUNT BELOW SIGN 415
IN 2 INSTALLATIONS

421 QUANTITY REQ'D 6



36 X 36
S1-1

YELLOW/GREEN REFLECTIVE SHEETING

ONE "U" POST PER SIGN

426 QUANTITY REQ'D 4

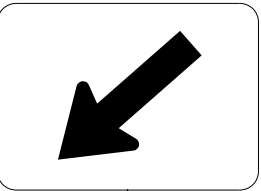

24 X 12
W16-7p

MOUNT BELOW SIGN 421
IN 4 INSTALLATIONS

427 QUANTITY REQ'D 2

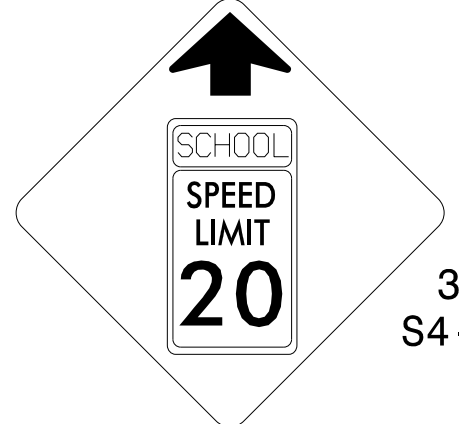

36 X 36
S4-5

ONE "U" POST PER SIGN

432 QUANTITY REQ'D 1

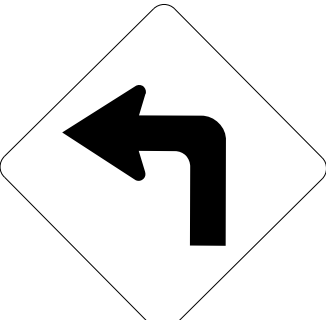

30 X 30
W1-1L

ONE "U" POST PER SIGN

402 QUANTITY REQ'D 1



18 x 24
W16-1P

MOUNT BELOW SIGN 401
IN 1 INSTALLATION

407 QUANTITY REQ'D 4



36 X 24
R5-1a

ONE "U" POST PER SIGN

412 QUANTITY REQ'D 10

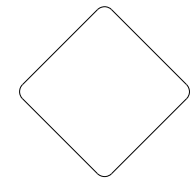

18 X 18
OM4-1

ONE "U" POST PER SIGN

417 QUANTITY REQ'D 12



36 X 12
R6-1 (R)

MOUNT ABOVE SIGN 409
IN 7 INSTALLATIONS

422 QUANTITY REQ'D 1

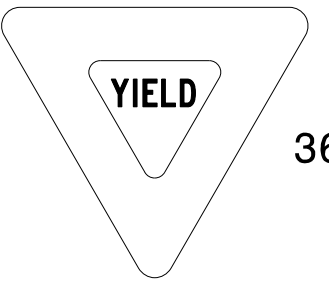

36 X 36 X 36
R1-2

ONE "U" POST PER SIGN

428 QUANTITY REQ'D 6



24 X 8
S4-3P

MOUNT ABOVE SIGN 421
IN 2 INSTALLATIONS
MOUNT ABOVE SIGN 420
IN 4 INSTALLATIONS

433 QUANTITY REQ'D 7

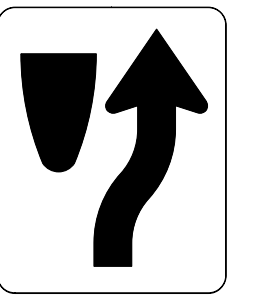

24 X 30
R4-7

ONE "U" POST PER SIGN

403 QUANTITY REQ'D 10



30 X 30
R5-1

MOUNT BACK TO BACK WITH SIGN 409
IN 2 INSTALLATION

408 QUANTITY REQ'D 1

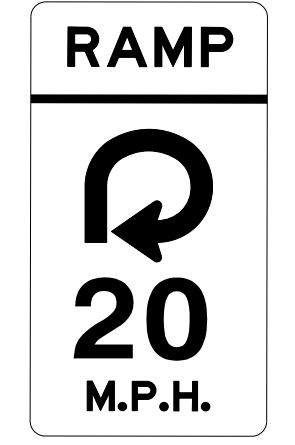

24 x 42
W13-7

ONE "U" POST PER SIGN

413 QUANTITY REQ'D 1

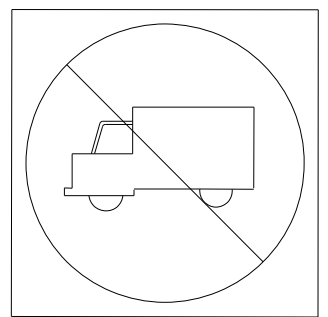

24 X 24
R5-2

ONE "U" POST PER SIGN

418 QUANTITY REQ'D 5

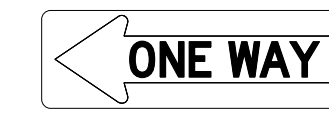

36 X 12
R6-1 (L)

MOUNT BACK TO BACK WITH
SIGN 417 IN 4 INSTALLATIONS

423 QUANTITY REQ'D 4

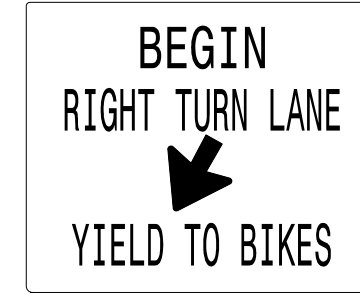

36 x 30
R4-4

ONE "U" POST PER SIGN

429 QUANTITY REQ'D 4

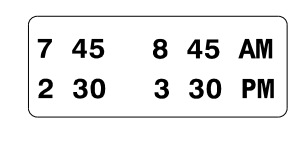

24 X 10
S4-1P

MOUNT BELOW SIGN 420
IN 4 INSTALLATIONS

434 QUANTITY REQ'D 6

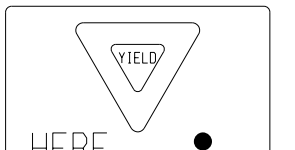

36 X 36
R1-5L

ONE "U" POST PER SIGN

404 QUANTITY REQ'D 2



18 X 18
W13-1P

MOUNT BELOW SIGN 431
IN 2 INSTALLATION

409 QUANTITY REQ'D 11

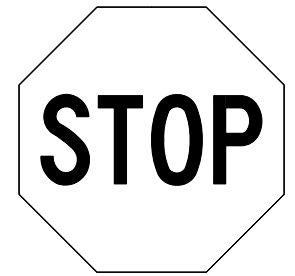

36 X 36
R1-1

ONE "U" POST PER SIGN

414 QUANTITY REQ'D 5



36 X 36
R3-7

ONE "U" POST PER SIGN

419 QUANTITY REQ'D 2



30 x 30
W14-2

ONE "U" POST PER SIGN

424 QUANTITY REQ'D 2



36 X 36
S4-5

ONE "U" POST PER SIGN

430 QUANTITY REQ'D 5

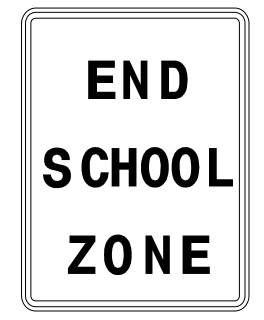

24 X 30
S5-2

ONE "U" POST PER SIGN

435 QUANTITY REQ'D 6

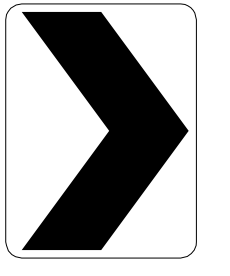

30 X 36
W1-8R

ONE "U" POST PER SIGN

405 QUANTITY REQ'D 3



54 X 18
R6-1 (R)

TWO "U" POSTS PER SIGN

410 QUANTITY REQ'D 3

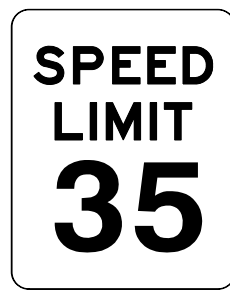

24 X 30
R2-1

ONE "U" POST PER SIGN

415 QUANTITY REQ'D 2



24 X 18
R3-17

ONE "U" POST PER SIGN

420 QUANTITY REQ'D 4



24 X 30
R2-1

ONE "U" POST PER SIGN

425 QUANTITY REQ'D 2

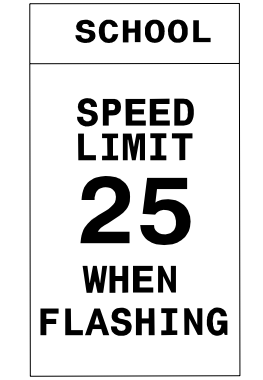

24 X 48
S5-1

ONE "U" POST PER SIGN

431 QUANTITY REQ'D 1

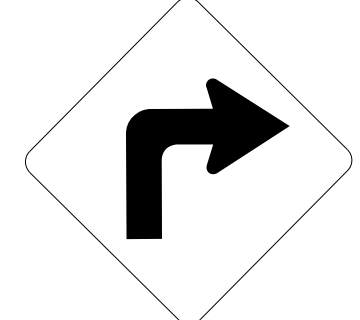

30 X 30
W1-1R

ONE "U" POST PER SIGN

TYPE "E" SIGNS

4/6/2015 P:\Projects-U\U3308-Traffic\Signing\CADD\Signing Layout Plans\U-3308-SGN5HT-1.dgn

APPROVED: *Ronald W. King*
 DATE: 4/6/2015

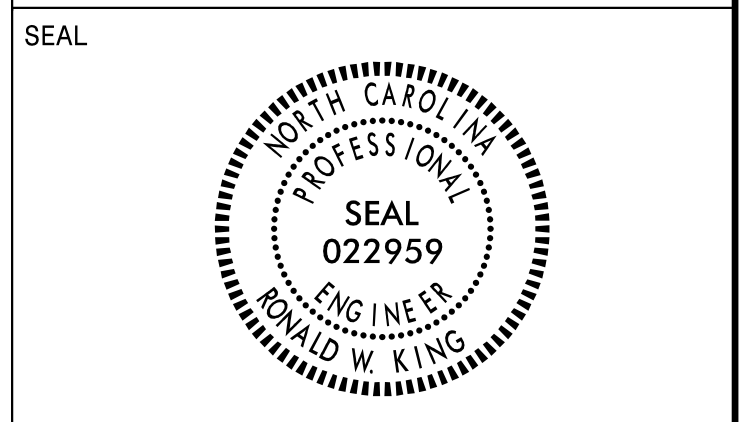

501 511

JCT 1-21 x 15
 147 1-30 x 24

ONE "U" POST PER SIGN

506

WEST EAST 2-24 x 12
 55 55 2-24 x 24
 ← → 2-21 x 15

TWO "U" POSTS PER SIGN

512 523

WEST 1-24 x 12
 55 1-24 x 24

ONE "U" POST PER SIGN

520

WEST 1-24 x 12
 BUSINESS WEST 2-24 x 12
 70 98 2-24 x 24
 EAST WEST 2-24 x 12
 55 55 2-24 x 24
 ← → 2-21 x 15

TWO "U" POSTS PER SIGN

521

WEST 1-24 x 12
 BUSINESS WEST 2-24 x 12
 70 98 2-24 x 24

TWO "U" POSTS PER SIGN

522

EAST 1-24 x 12
 BUSINESS EAST 2-24 x 12
 70 98 2-24 x 24
 WEST EAST 2-24 x 12
 55 55 2-24 x 24
 ← → 2-21 x 15

TWO "U" POSTS PER SIGN

525

EAST WEST 2-24 x 12
 BUSINESS BUSINESS 2-24 x 12
 70 70 2-24 x 24
 EAST WEST 2-24 x 12
 98 98 2-24 x 24
 ← → 2-21 x 15

TWO "U" POSTS PER SIGN

502 513 514 526

EAST 1-24 x 12
 55 1-24 x 24

ONE "U" POST PER SIGN

507

SOUTH EAST 2-24 x 12
 147 55 1-30 x 24
 1-24 x 24
 ← → 2-21 x 15

TWO "U" POSTS PER SIGN

515 524

EAST 1-24 x 12
 BUSINESS 1-24 x 12
 70 1-24 x 24
 98 1-24 x 24

ONE "U" POST PER SIGN

503

NORTH SOUTH 2-24 x 12
 147 147 2-30 x 24
 ↑ → 2-21 x 15

TWO "U" POSTS PER SIGN

508

NORTH 1-24 x 12
 147 H 1-30 x 24
 1-24 x 24
 → → 2-21 x 15

TWO "U" POSTS PER SIGN

516

WEST EAST 2-24 x 12
 BUSINESS BUSINESS 2-24 x 12
 70 70 2-24 x 24
 WEST EAST 2-24 x 12
 98 98 2-24 x 24
 ← → 2-21 x 15

TWO "U" POSTS PER SIGN

504

WEST NORTH 2-24 x 12
 55 147 1-24 x 24
 1-30 x 24
 ↑ → 2-21 x 15

TWO "U" POSTS PER SIGN

509

H 1-24 x 24
 → 1-21 x 15
 SOUTH NORTH 2-24 x 12
 147 147 2-30 x 24
 ↑ → 2-21 x 15

TWO "U" POSTS PER SIGN

517

EAST 1-24 x 12
 BUSINESS EAST 2-24 x 12
 70 98 2-24 x 24

TWO "U" POSTS PER SIGN

505

SOUTH 1-24 x 12
 147 1-30 x 24
 ← 1-21 x 15

ONE "U" POST PER SIGN

510

WEST EAST 2-24 x 12
 55 55 2-24 x 24
 ← → 2-21 x 15

TWO "U" POSTS PER SIGN

518 519

JCT 1-21 x 15
 55 1-24 x 24

ONE "U" POST PER SIGN

SIGN NUMBER: 301,302 BACKG COLOR: Brown
 TYPE: D COPY COLOR: White
 QUANTITY: 2
 SIGN WIDTH: 4'-6" HEIGHT: 2'-6"
 TOTAL AREA: 11.3 Sq.Ft.
 BORDER TYPE: FLUSH RECESS: 0" WIDTH: 1" RADII: 3"
 NO. Z BARS: LENGTH:

SYMBOL	X	Y	WID	HT
Historic Sites	3.3	6.8	18	10.7

MAT'L: 0.125" (3.2 mm) ALUMINUM

USE NOTES: 1,2
 1. Legend and border (except those that are colored black) shall be direct applied Grade C sheeting.
 2. Background shall be Grade C reflective sheeting.

DESIGN BY: S.Johns CHECKED BY: R.Roach DATE: Mar 11, 2015
 PROJECT ID: U-3308 DIV: 5

Spacing Factor is 1 unless specified otherwise

LETTER POSITIONS

Letter spacings are to start of next letter

	G	O	L	D	E	N	B	E	L	T		Series/Size		
	19.7	3.5	3.3	1.4	3.3	3.2	2.6	4	3.4	3.2	1.2	1.8	3.3	C 2000
														31
														C 2000
	26.3	3.8	1.3	2.3	2.2	3.3	2.2	1.4	2.5	8.6				19.1
														C 2000
	27.1	3.7	1.3	2.3	2.3	2.2	1.4	2.7	1.8	9.1				17.8

FILENAME: GoldenBeltSign.dgn

NORTH CAROLINA D.O.T. SIGN DETAIL

TYPES "D" & "F" SIGNS

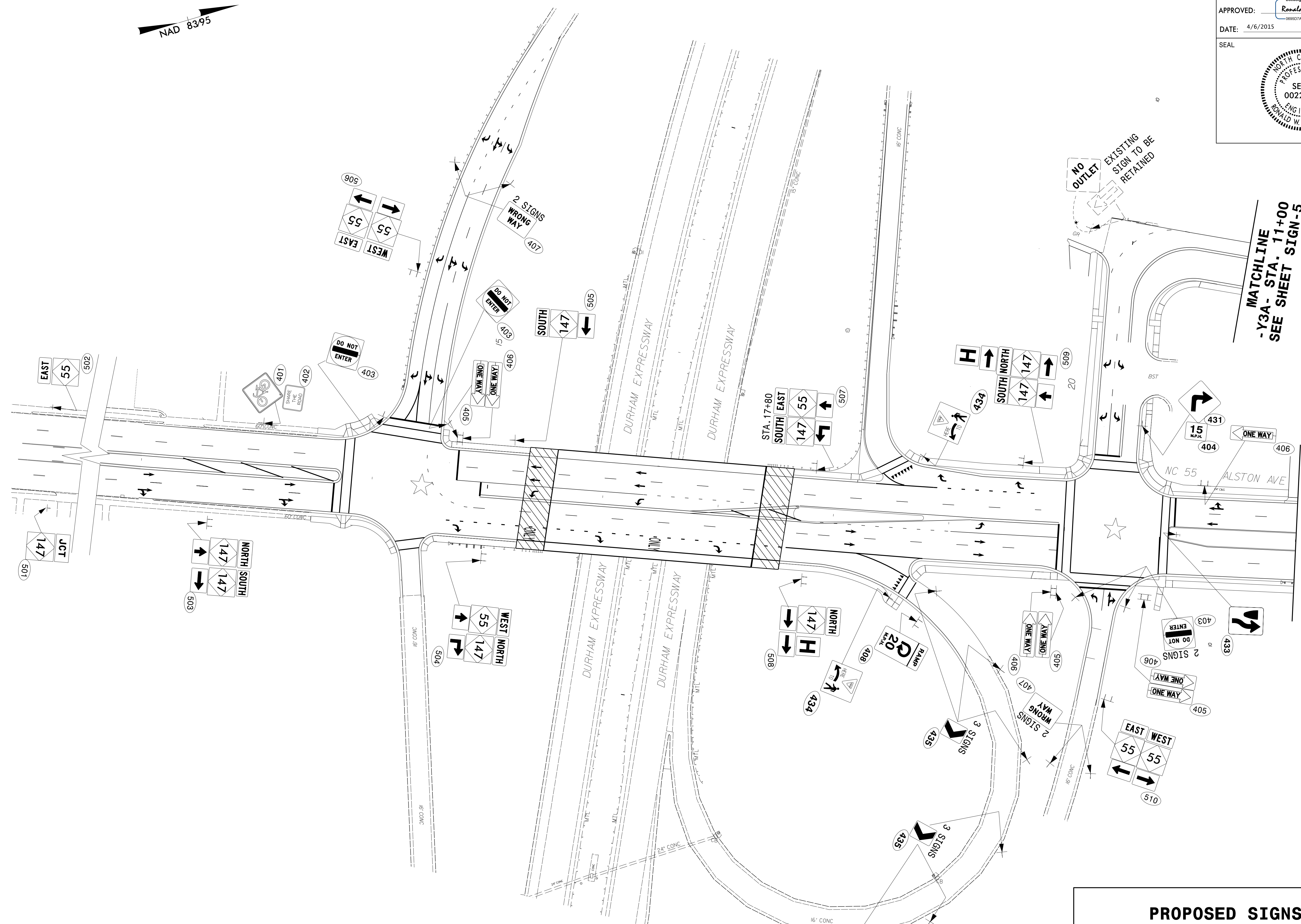
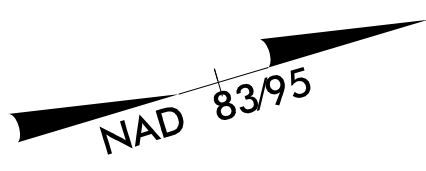

4/6/2015 P:\Projects-U\U3308-Traffic\Signing\CADD\Signing Layout Plans\U-3308-SGN5HT-1.dgn



MATCHLINE
-Y3A- STA. 11+00
SEE SHEET SIGN-5

MATCHLINE
-LALT- STA. 22+00
SEE SHEET SIGN-5

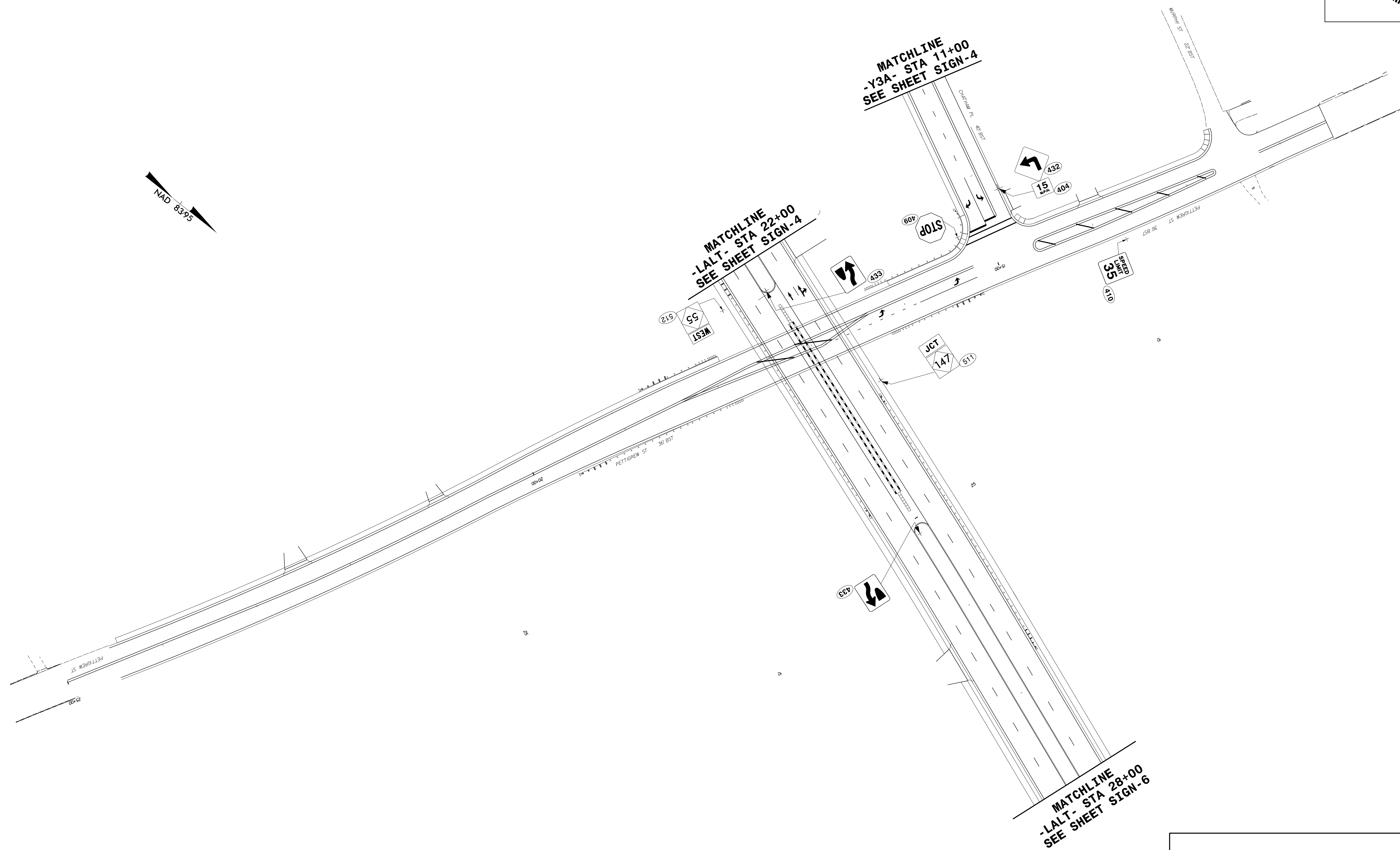
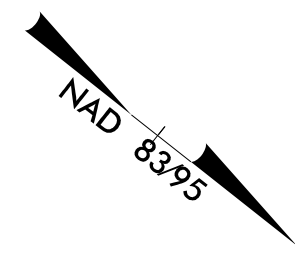

**PROPOSED SIGNS
STA. 12+00 TO STA. 22+00**

PROJECT REFERENCE NO. U-3308	SHEET NO. SIGN-5
APPROVED:  0696074867740DC	
DATE: 4/6/2015	
SEAL	
	



**PROPOSED SIGNS
STA. 22+00 TO 28+00**

4/6/2015
 P:\Projects\UN3308\Traffic\Signing\CADD\Signing Layout Plans\U-3308-SGN5HT_5.dgn
 Jseris:rbns

PROJECT REFERENCE NO. U-3308	SHEET NO. SIGN-6
APPROVED:  069807486774DC	
DATE: 4/6/2015	
SEAL	
	



MATCHLINE
 -LALT- STA 28+00
 SEE SHEET SIGN-5

MATCHLINE
 -LALT- STA 40+00
 SEE SHEET SIGN-7

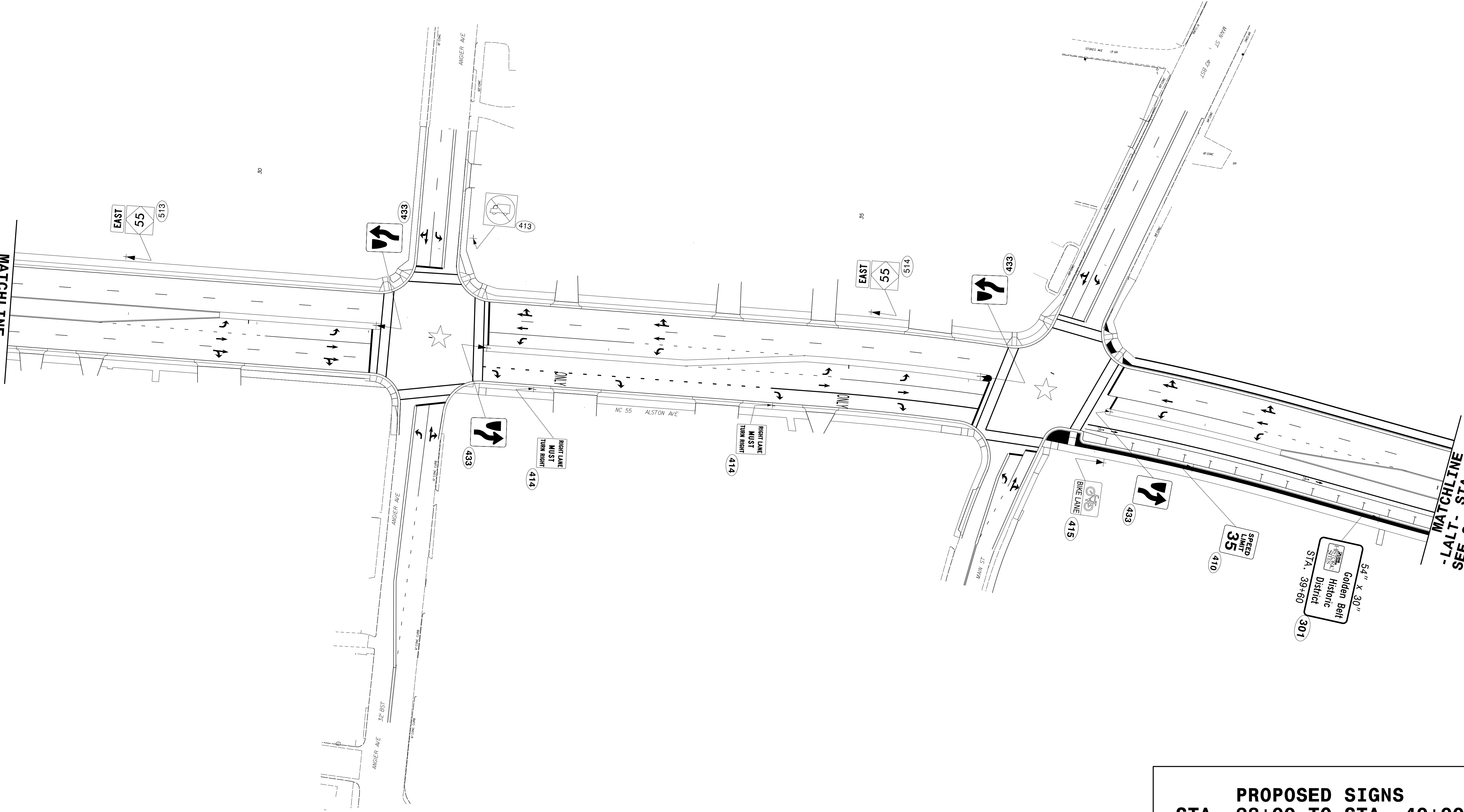

PROPOSED SIGNS
STA. 28+00 TO STA. 40+00

4/6/2015
 P:\TIP\Projects-U\U3308\Traffic\Signing\CADD\Signing Layout Plans\U-3308-SGN5HT_6.dgn
 Jseris.tbl

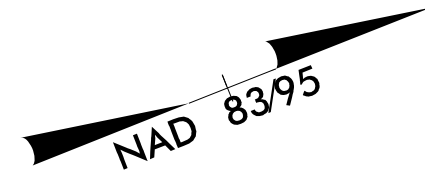

MATCHLINE
- LALT- STA 40+00
SEE SHEET SIGN-6

MATCHLINE
- LALT- STA 47+30
SEE SHEET SIGN-8

PROPOSED SIGNS
STA. 40+00 TO STA. 47+30



PROJECT REFERENCE NO. U-3308	SHEET NO. SIGN-9
APPROVED: <i>Ronald W. King</i> 069807AB67C4DC...	
DATE: 4/6/2015	
SEAL	

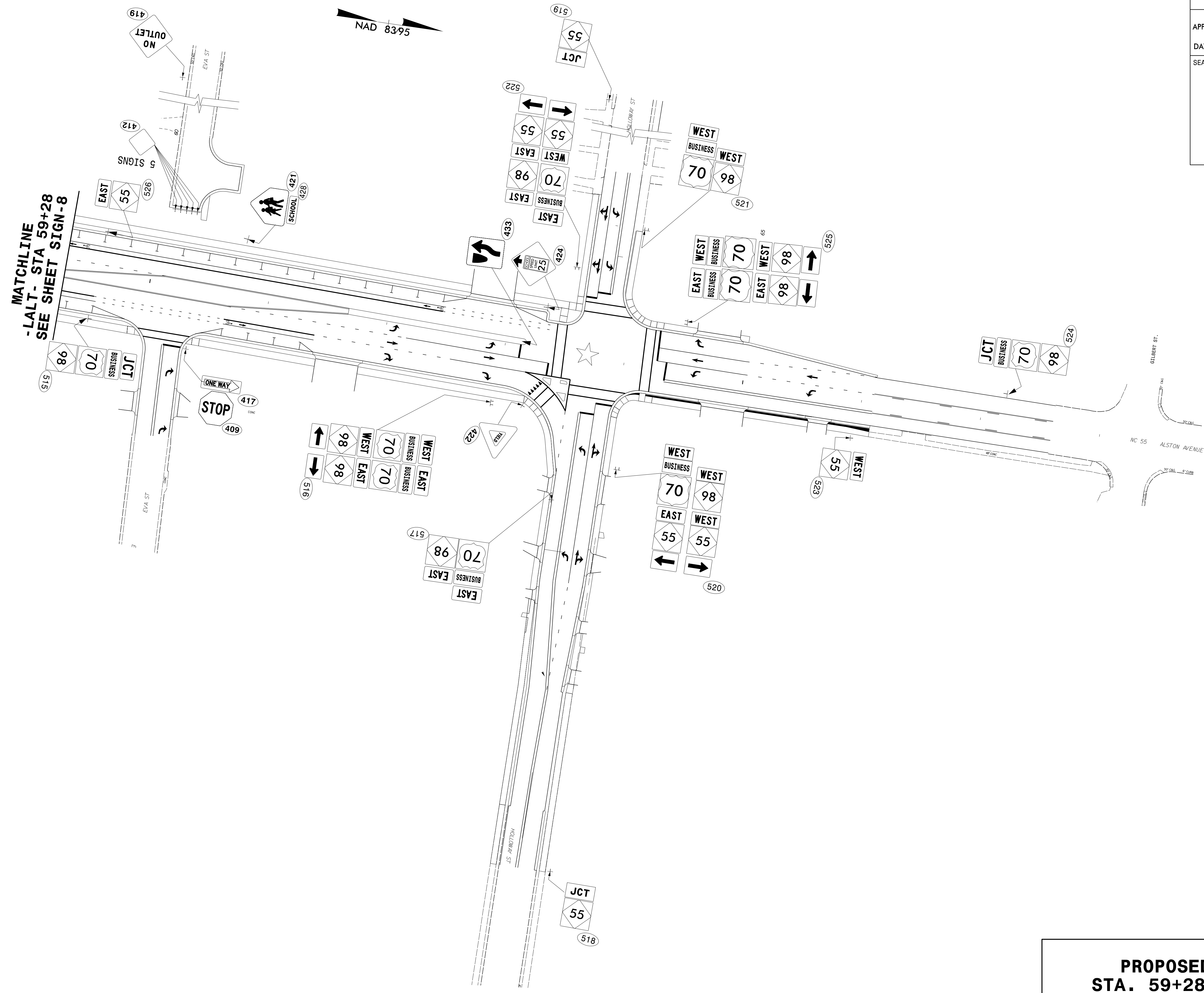

MATCHLINE
-LALT- STA 59+28
SEE SHEET SIGN-8



**PROPOSED SIGNS
STA. 59+28 TO 67+60**

PROJECT REFERENCE NO. U-3308	SHEET NO. SIGN-10
APPROVED:  069807486774DC...	
DATE: 4/6/2015	
SEAL	
	

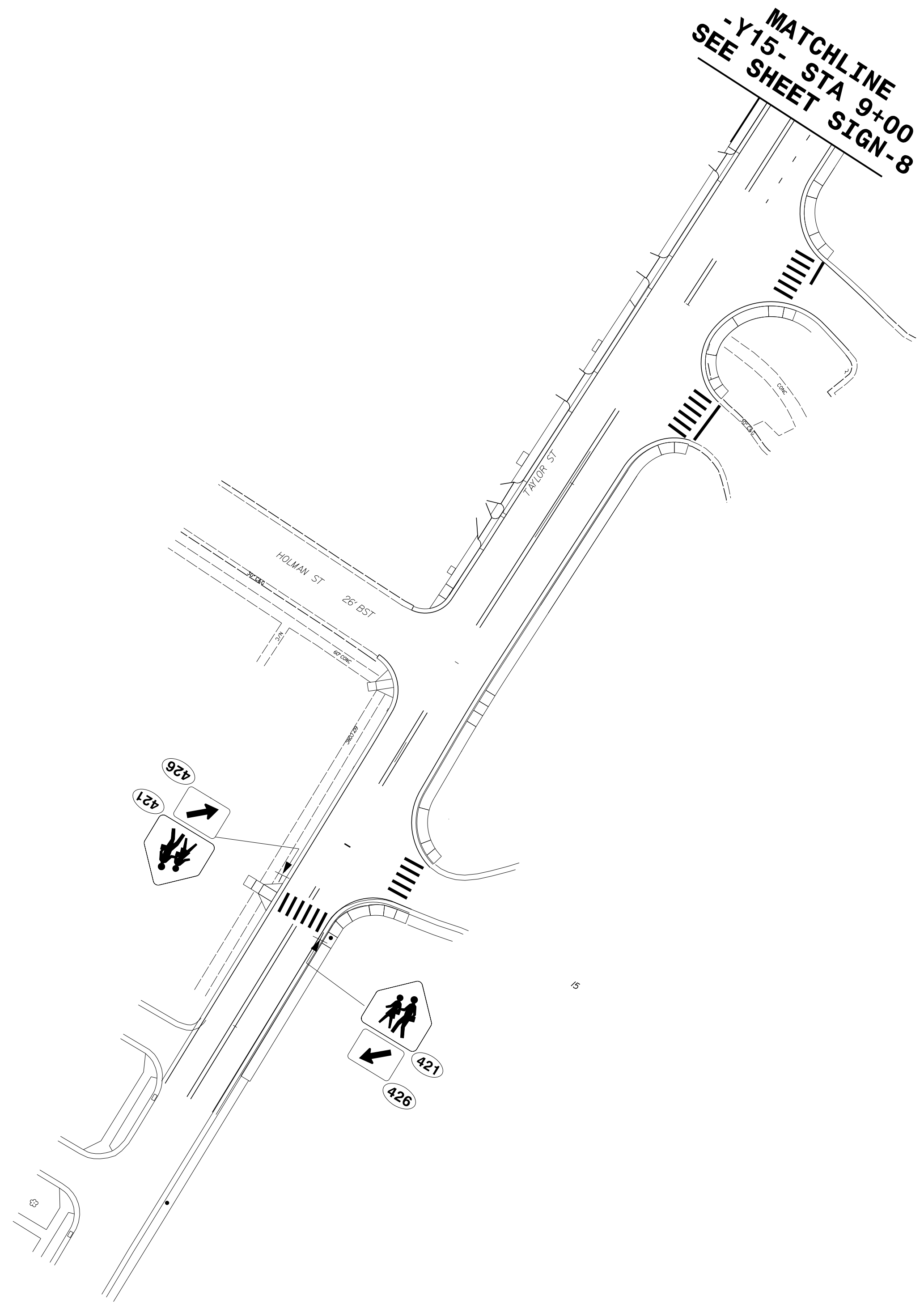
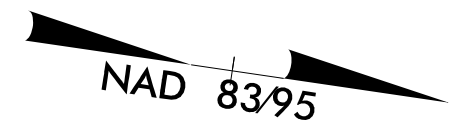

**PROPOSED SIGNS
STA. 9+00 TO 15+40**

4/6/2015
 P:\Projects\UNU3308\Traffic\Signing\CADD\Signing Layout Plans\U-3308-SGN-SHT_10.dgn
 Insertions