

**NOTES**

STIRRUPS IN CAP MAY BE SHIFTED AS NECESSARY TO CLEAR DOWELS.

THE CONCRETE IN THE SHADED AREA OF THE WING SHALL BE POURED AFTER THE VERTICAL CONCRETE BARRIER RAIL IS CAST IF SLIP FORMING IS USED.

FOR PILE SPLICE DETAILS, SEE SHEET 4 OF 4.

FOR WING DETAILS, SEE SHEET 3 OF 4.

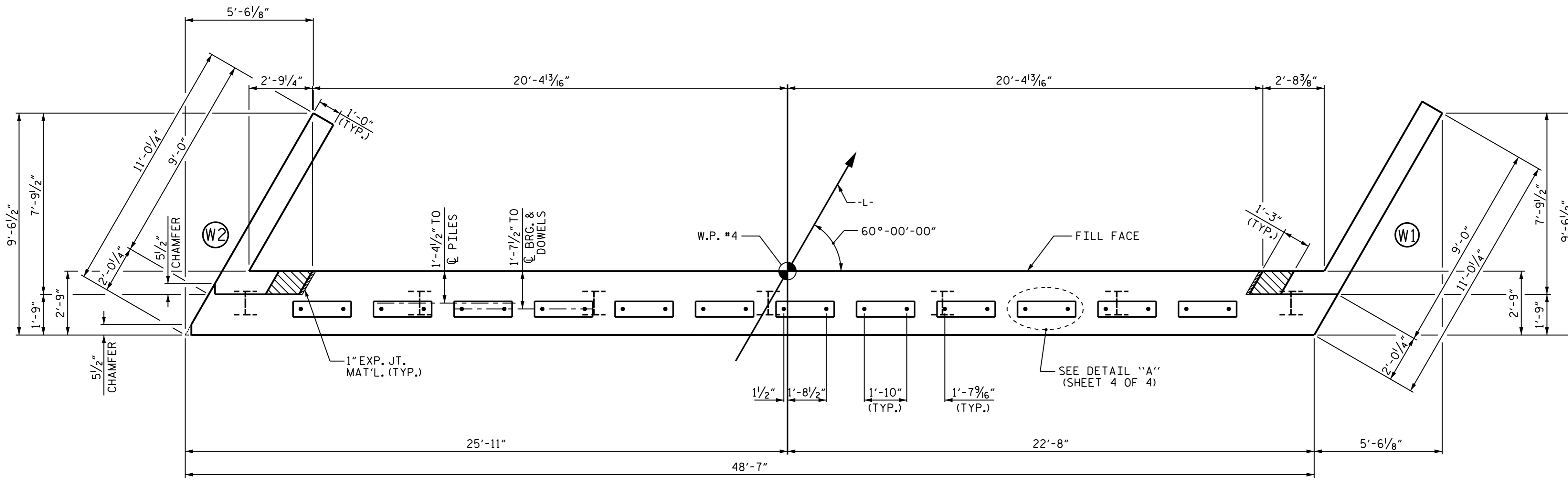

**PLAN**

TOP OF PILE ELEVATIONS	
①	169.48
②	169.64
③	169.80
④	169.96
⑤	170.12
⑥	170.28
⑦	170.44

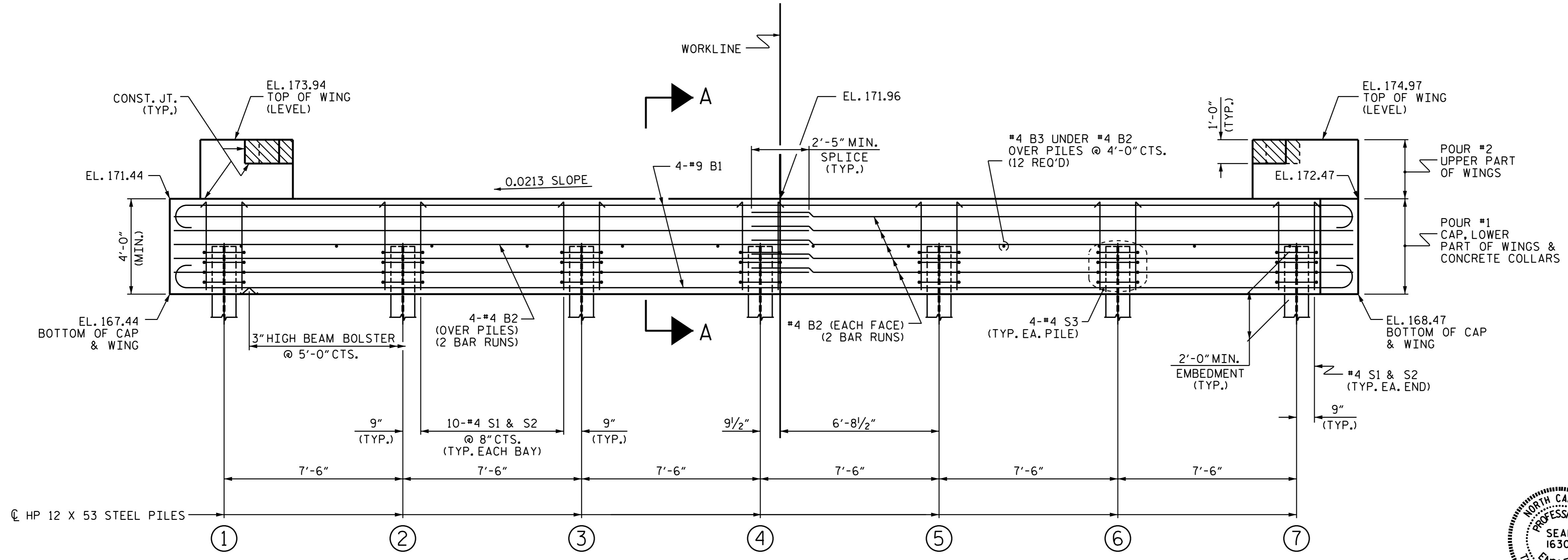

**ELEVATION**

WINGS NOT SHOWN FOR CLARITY.  
FOR SECTION A-A, SEE SHEET 4 OF 4.  
CONCRETE COLLARS FOR STEEL PILES NOT SHOWN IN PLAN AND ELEVATION VIEWS FOR CLARITY.  
SEE "CORROSION PROTECTION FOR STEEL PILES DETAIL", SHEET 4 OF 4.

PROJECT NO. B-4461  
CHATHAM COUNTY  
STATION: 19+12.00 -L-

SHEET 2 OF 4

STATE OF NORTH CAROLINA  
DEPARTMENT OF TRANSPORTATION  
RALEIGH

SUBSTRUCTURE  
END BENT 2

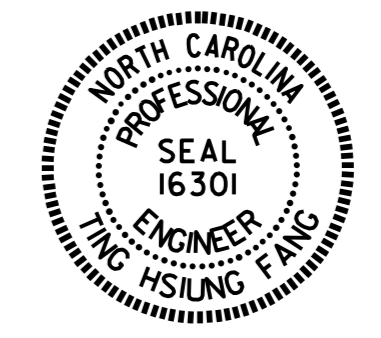

DocuSigned by:  
Ting Fang  
4/11/2016

ASSEMBLED BY : S. WANCE	DATE : 7/14
CHECKED BY : W. F. PARKER	DATE : 9/15
DRAWN BY : WJH 12/11	REV. 4/15
CHECKED BY : AAC 12/11	MAA/TMG

REVISIONS						SHEET NO.
NO.	BY:	DATE:	NO.	BY:	DATE:	S-15
1			3			TOTAL SHEETS
2			4			23

DOCUMENT NOT CONSIDERED  
FINAL UNLESS ALL  
SIGNATURES COMPLETED