

PLAN

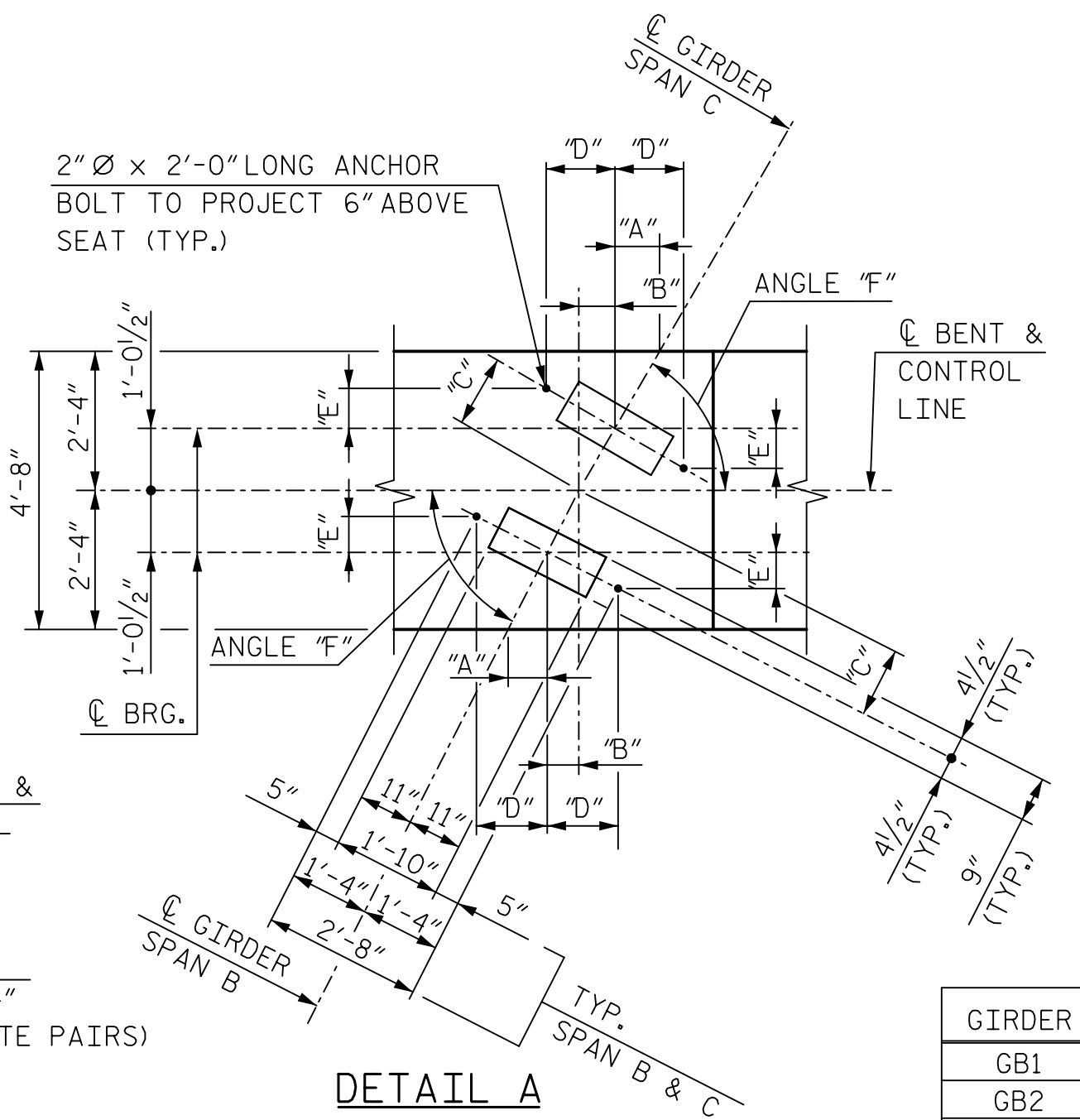

DETAIL A

NOTES:
 STIRRUPS IN CAP MAY BE SHIFTED AS NECESSARY TO CLEAR ANCHOR BOLTS.
 HOOKS ON "V" BARS MAY BE TURNED AS NECESSARY FOR PLACING REINFORCING STEEL.
 ALL STEEL IN THE DRILLED PIERS IS INCLUDED IN THE PAY ITEMS FOR "REINFORCING STEEL" AND "SPIRAL COLUMN REINFORCING STEEL".

GIRDER	"A"	"B"	"C"	"D"	"E"	ANGLE "F"
GB1	8 7/8"	7 1/8"	1'-2 3/8"	1'-1 7/8"	7 15/16"	60°-17'-19"
GB2	8 15/16"	7 3/16"	1'-2 7/16"	1'-1 7/8"	8"	60°-04'-21"
GB3	9"	7 1/4"	1'-2 7/16"	1'-1 13/16"	8 1/16"	59°-51'-11"
GB4	9 1/16"	7 5/16"	1'-2 1/2"	1'-1 13/16"	8 1/16"	59°-37'-48"
GC1	10"	8 1/16"	1'-2 7/8"	1'-1 7/16"	8 1/16"	57°-10'-31"
GC2	10 1/16"	8 1/8"	1'-2 15/16"	1'-1 7/16"	8 3/4"	56°-55'-51"
GC3	10 3/16"	8 3/16"	1'-2 15/16"	1'-1 3/8"	8 3/16"	56°-40'-56"
GC4	10 5/16"	8 5/16"	1'-3"	1'-1 5/16"	8 7/8"	56°-25'-48"

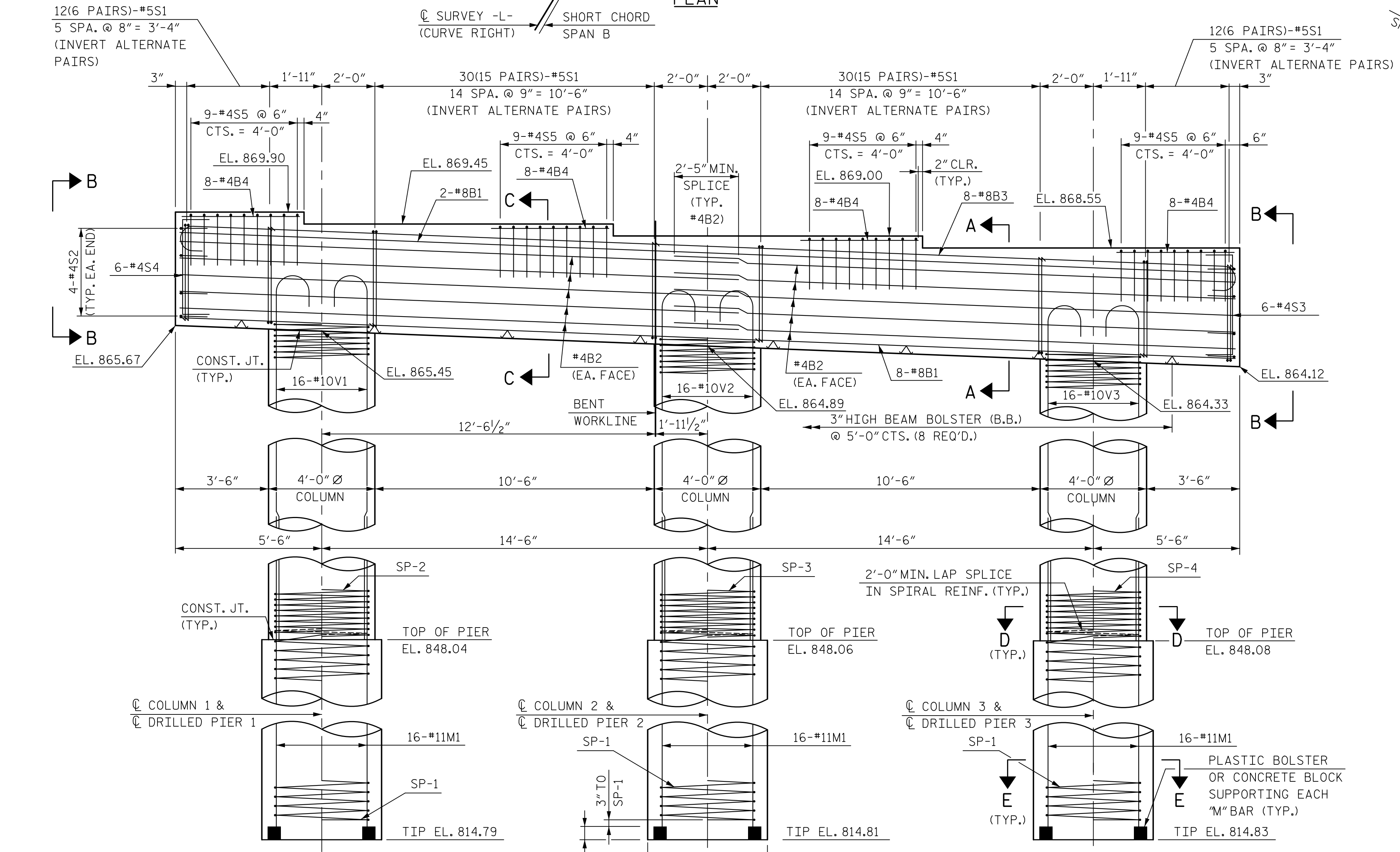

ELEVATION

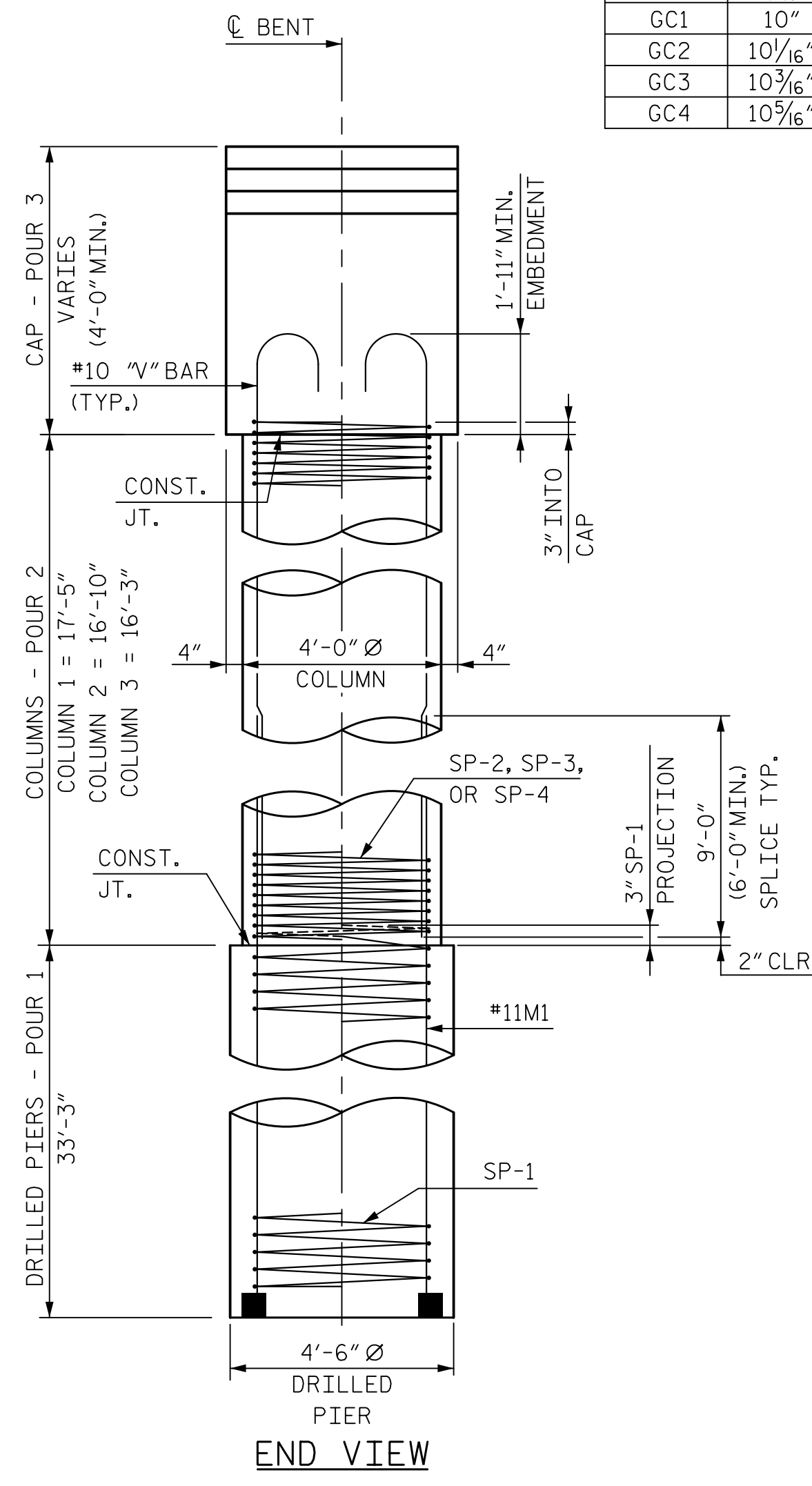

END VIEW

DocuSigned by:
 David W. Hawkins
 NORTH CAROLINA PROFESSIONAL SEAL 27812
 ENGINEER
 DAVID W. HAWKINS
 1/29/2016

DocuSigned by:
 Paul J. Barber
 NORTH CAROLINA PROFESSIONAL SEAL 12916
 ENGINEER
 PAUL J. BARBER
 1/29/2016

PROJECT NO. B-4811
 RUTHERFORD COUNTY
 STATION: POC 15+25.00 -L-

SHEET 1 OF 2
 STATE OF NORTH CAROLINA
 DEPARTMENT OF TRANSPORTATION
 RALEIGH
 SUBSTRUCTURE
 BENT 2

HNTB HNTB NORTH CAROLINA, P.C.
 NC License No. C-1554
 343 E. Six Forks Rd., Suite 200, Raleigh, N.C. 27609

DOCUMENT NOT CONSIDERED FINAL UNLESS ALL SIGNATURES COMPLETED

DRAWN BY: M. WRIGHT DATE: 11/14
 CHECKED BY: D. RAGAN DATE: 2/15 DWG. NO. 33

REVISIONS					
NO.	BY	DATE	NO.	BY	DATE
1			3		
2			4		

SHEET NO. S01-33
 TOTAL SHEETS 42