

PROJECT REFERENCE NO.	SHEET NO.
B-4811	EC-4/CONST.4
RW SHEET NO.	
ROADWAY DESIGN ENGINEER	HYDRAULICS ENGINEER

NOTE:
UTILIZE TEMPORARY SEDIMENT BASIN OR SPECIAL STILLING BASIN(S) AS STILLING BASIN WHERE APPLICABLE.

26 x 13 x 3
1.5 inch Skimmer
with 0.375 inch
Orifice Diameter
4 ft. weir
ID 4.1

16 x 32 x 3
1.5 inch Skimmer
with 0.5 inch
Orifice Diameter
4 ft. weir
ID 4.3

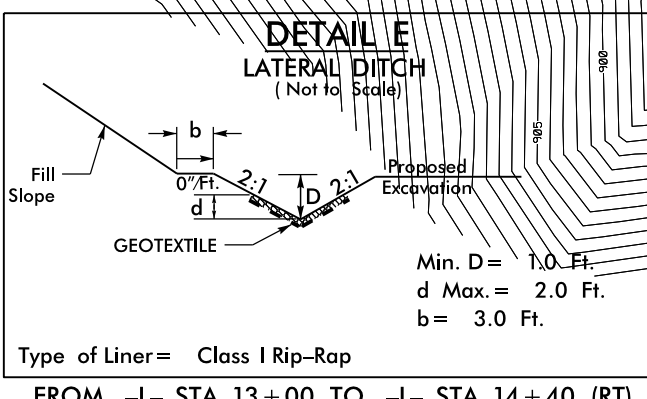
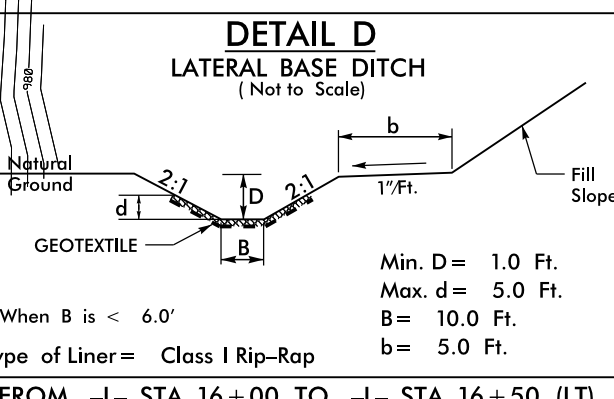
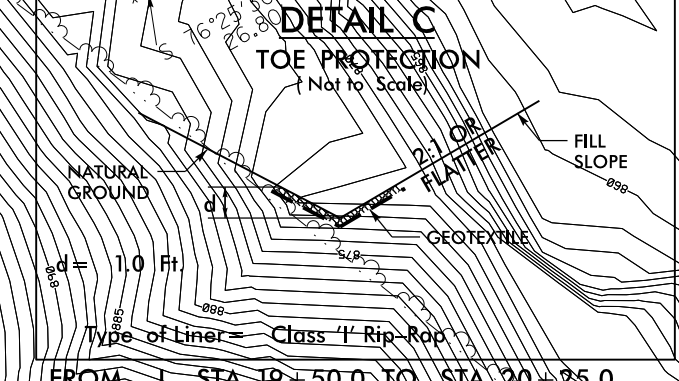
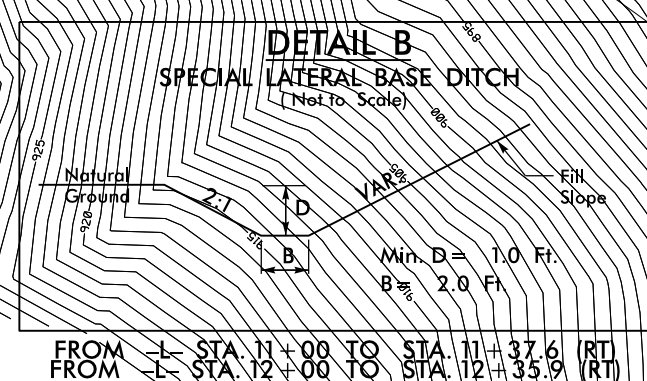
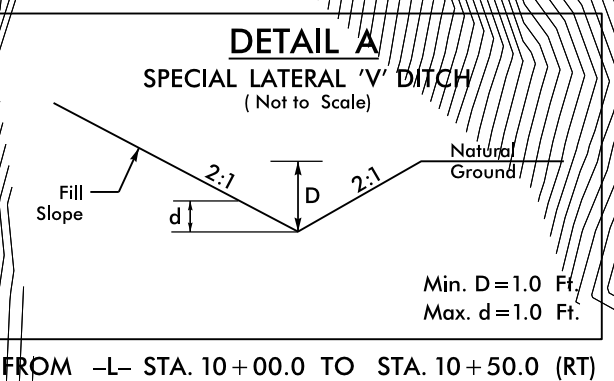
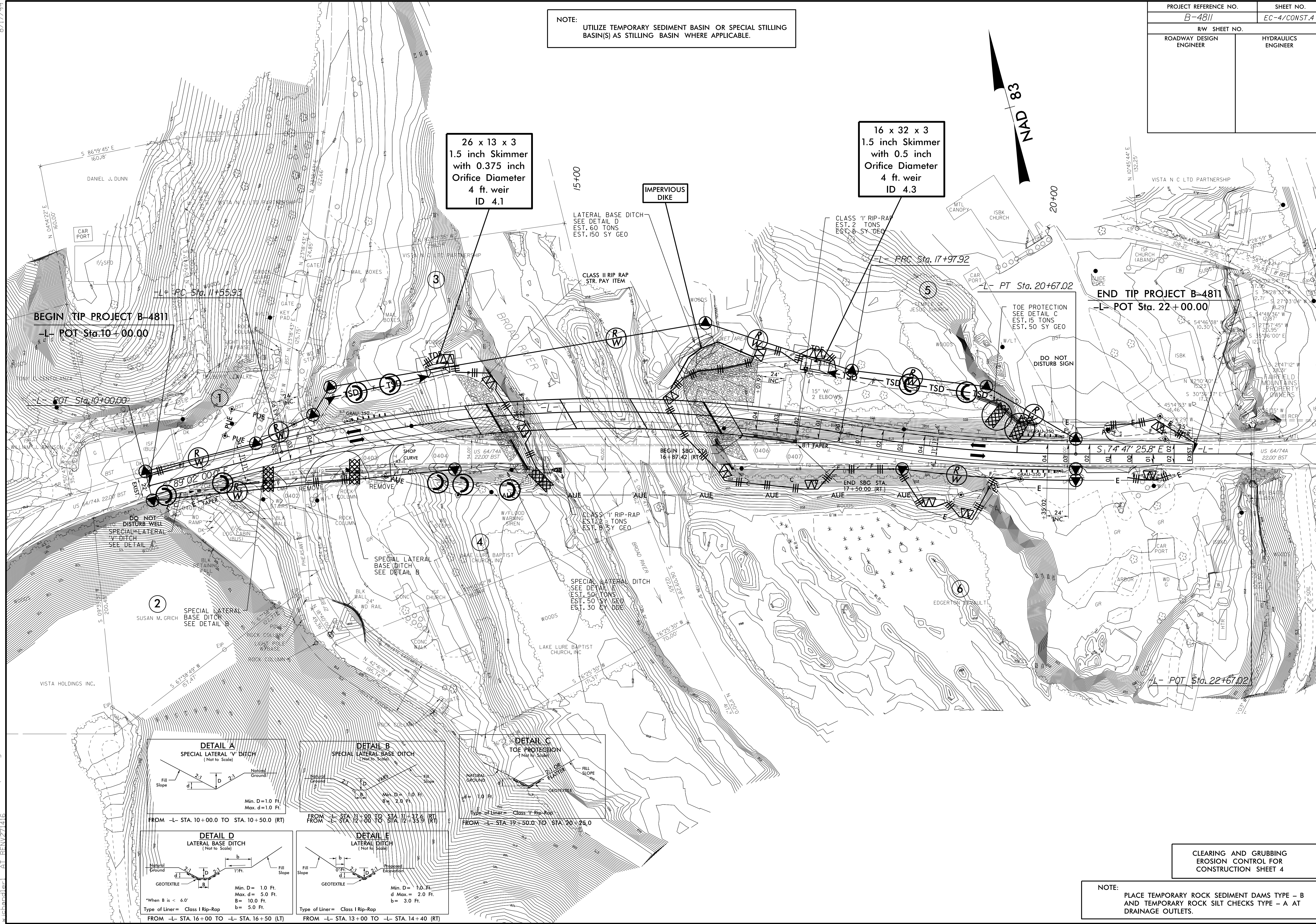
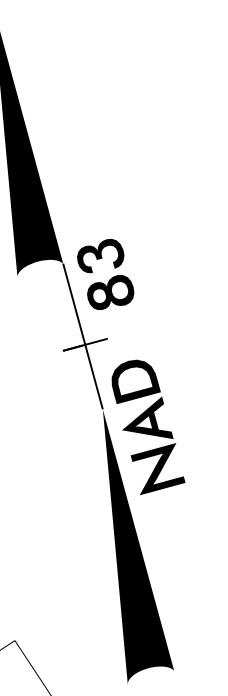

NOTE:
PLACE TEMPORARY ROCK SEDIMENT DAMS TYPE - B
AND TEMPORARY ROCK SILT CHECKS TYPE - A AT
DRAINAGE OUTLETS.

8/17/99
28-DEC-2015 08:44 D:\as191\B-4811-EC.psh4.dgn
R:\as191\B-4811-EC.psh4.dgn
R:\as191\B-4811-EC.psh4.dgn