

PROJECT: 34845.1.1 ID. U-2707

STATE OF NORTH CAROLINA
DEPARTMENT OF TRANSPORTATION
DIVISION OF HIGHWAYS
GEOTECHNICAL UNIT

ROADWAY
SUBSURFACE INVESTIGATION

STATE PROJECT 34845.1.1 I.D. NO. U-2707
F.A. PROJECT STP-3000(1)
COUNTY FORSYTH
DESCRIPTION SR 3000 (IDOLS RD.) FROM SR 2999
(HAMPTON RD.) TO US 158 (CLEMMONS RD.)

INVENTORY

CONTENTS:

DRAWN BY: J.K. McCLURE

NOTE - THE INFORMATION CONTAINED HEREIN IS NOT IMPLIED OR GUARANTEED BY THE N.C. DEPARTMENT OF TRANSPORTATION AS BEING ACCURATE NOR IS IT CONSIDERED TO BE PART OF THE PLANS, SPECIFICATIONS, OR CONTRACT FOR THE PROJECT.

NOTE - BY HAVING REQUESTED THIS INFORMATION THE CONTRACTOR SPECIFICALLY WAIVES ANY CLAIMS FOR INCREASED COMPENSATION OR EXTENSION OF TIME BASED ON DIFFERENCES BETWEEN THE CONDITIONS INDICATED HEREIN AND THE ACTUAL CONDITIONS AT THE PROJECT SITE.

STATE	STATE PROJECT REFERENCE NO.	SHEET	SHEETS
N.C.	U-2707	1	19
STATE PROJ. NO.	F.A. PROJ. NO.	DESCRIPTION	
34845.1.1	STP-3000(1)	P.E.	
		CONST.	

CAUTION NOTICE

THE SUBSURFACE INFORMATION AND THE SUBSURFACE INVESTIGATION ON WHICH IT IS BASED WAS MADE FOR THE PURPOSE OF STUDY, PLANNING AND DESIGN, AND NOT FOR CONSTRUCTION OR PAY PURPOSES. THE VARIOUS FIELD BORING LOGS, ROCK CORES, AND SOIL TEST DATA AVAILABLE MAY BE REVIEWED OR INSPECTED IN RALEIGH BY CONTACTING THE N.C. DEPARTMENT OF TRANSPORTATION, GEOTECHNICAL UNIT @ (919) 250-4088. NEITHER THE SUBSURFACE PLANS AND REPORTS, NOR THE FIELD BORING LOGS, ROCK CORES, OR SOIL TEST DATA IS PART OF THE CONTRACT.

GENERAL SOIL AND ROCK STRATA DESCRIPTIONS AND INDICATED BOUNDARIES ARE BASED ON A GEOTECHNICAL INTERPRETATION OF ALL AVAILABLE SUBSURFACE DATA AND MAY NOT NECESSARILY REFLECT THE ACTUAL SUBSURFACE CONDITIONS BETWEEN BORINGS OR BETWEEN SAMPLED STRATA WITHIN THE BOREHOLE. THE LABORATORY SAMPLE DATA AND THE IN SITU (IN-PLACE) TEST DATA CAN BE RELIED ON ONLY TO THE DEGREE OF RELIABILITY INHERENT IN THE STANDARD TEST METHOD. THE OBSERVED WATER LEVELS OR SOIL MOISTURE CONDITIONS INDICATED IN THE SUBSURFACE INVESTIGATIONS ARE AS RECORDED AT THE TIME OF THE INVESTIGATION. THESE WATER LEVELS OR SOIL MOISTURE CONDITIONS MAY VARY CONSIDERABLY WITH TIME ACCORDING TO CLIMATIC CONDITIONS INCLUDING TEMPERATURES, PRECIPITATION AND WIND, AS WELL AS OTHER NON-CLIMATIC FACTORS.

THE BIDDER OR CONTRACTOR IS CAUTIONED THAT DETAILS SHOWN ON THE SUBSURFACE PLANS ARE PRELIMINARY ONLY AND IN MANY CASES THE FINAL DESIGN DETAILS ARE DIFFERENT. FOR BIDDING AND CONSTRUCTION PURPOSES, REFER TO THE CONSTRUCTION PLANS AND DOCUMENTS FOR FINAL DESIGN INFORMATION ON THIS PROJECT. THE DEPARTMENT DOES NOT WARRANT OR GUARANTEE THE SUFFICIENCY OR ACCURACY OF THE INVESTIGATION MADE, NOR THE INTERPRETATIONS MADE OR OPINION OF THE DEPARTMENT AS TO THE TYPE OF MATERIALS AND CONDITIONS TO BE ENCOUNTERED. THE BIDDER OR CONTRACTOR IS CAUTIONED TO MAKE SUCH INDEPENDENT SUBSURFACE INVESTIGATIONS AS HE DEEMS NECESSARY TO SATISFY HIMSELF AS TO CONDITIONS TO BE ENCOUNTERED ON THIS PROJECT. THE CONTRACTOR SHALL HAVE NO CLAIM FOR ADDITIONAL COMPENSATION OR FOR AN EXTENSION OF TIME FOR ANY REASON RESULTING FROM THE ACTUAL CONDITIONS ENCOUNTERED AT THE SITE DIFFERING FROM THOSE INDICATED IN THE SUBSURFACE INFORMATION.

INVESTIGATED BY R.Q. CALLAWAY PERSONNEL C.C. MURRAY
CHECKED BY C.B. LITTLE J.E. ESTEP
SUBMITTED BY C.B. LITTLE J.W. VANDERBURG
DATE OCTOBER 2004

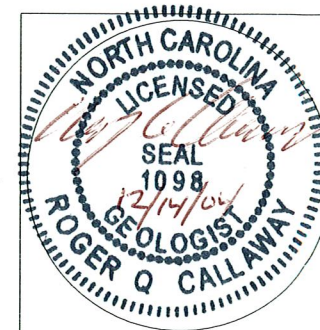

SEAL

Roger Q. Callaway
SIGNATURE

STATE OF NORTH CAROLINA
DIVISION OF HIGHWAYS

STATE	STATE PROJECT REFERENCE NO.	SHEET NO.	TOTAL SHEETS
N.C.	U-2707	2A	
STATE PROJ. NO.	F.A. PROJ. NO.	DESCRIPTION	
34845.1.1	STP-3000(1)	P.E.	

FORSYTH COUNTY

LOCATION: CLEMMONS - SR 3000 (IDOLS ROAD), FROM SR 2999 (HAMPTON ROAD) TO US 158 (CLEMMONS ROAD)
TYPE OF WORK: GRADING, DRAINAGE, PAVING, GUARDRAIL, AND STRUCTURES

CONTRACT: TIP PROJECT: U-2707

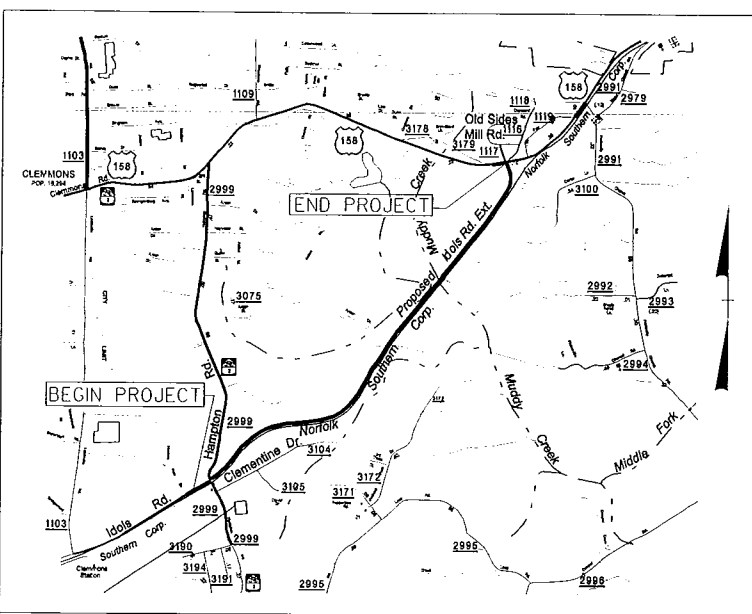

VICINITY MAP

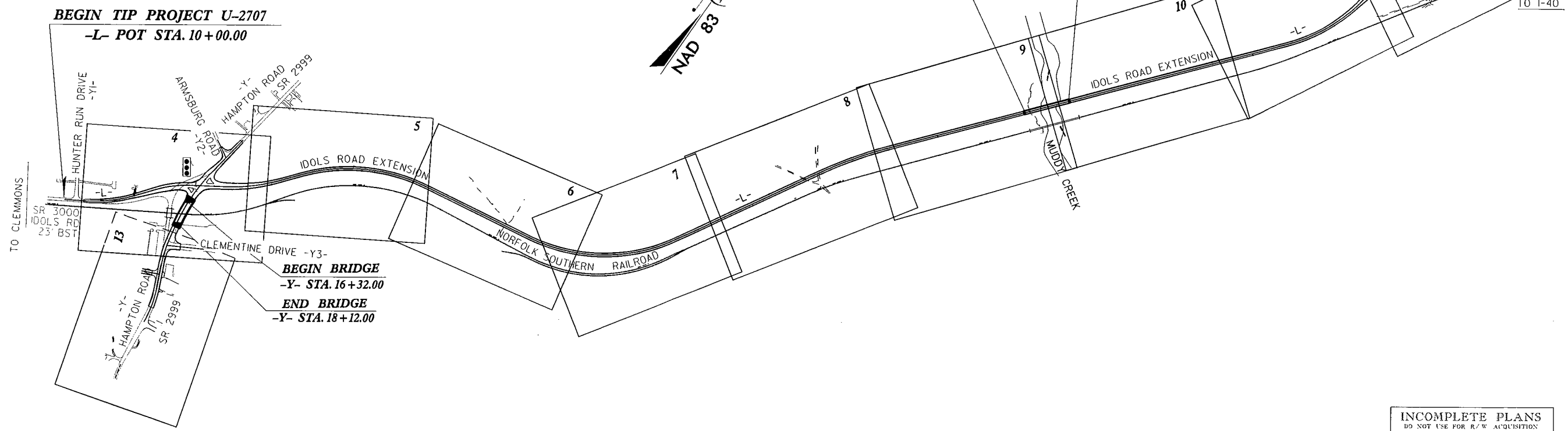

"THIS PROJECT IS WITHIN THE CLEMMONS MUNICIPAL BOUNDARIES."

CLEARING ON THIS PROJECT SHALL BE PERFORMED TO THE LIMITS ESTABLISHED BY METHOD _____

INCOMPLETE PLANS
DO NOT USE FOR R/W ACQUISITION
PRELIMINARY PLANS
DO NOT USE FOR CONSTRUCTION

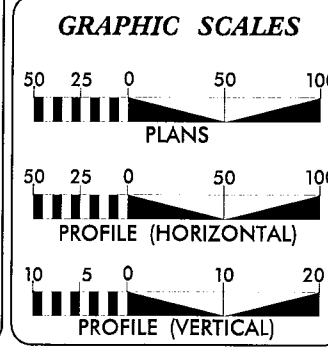

DESIGN DATA

ADT 2006 =	8523
ADT 2026 =	15466
DHV =	12 %
D =	60 %
T =	4 % *
V =	50 MPH
* TTST 1 %	DUAL 3 %
FUNC CLASS =	URBAN COLLECTOR

PROJECT LENGTH

LENGTH ROADWAY TIP PROJECT U-2707 =	2.040 Mile
LENGTH STRUCTURE TIP PROJECT U-2707 =	0.066 Mile
TOTAL LENGTH TIP PROJECT U-2707 =	2.106 Mile

NOTE: PROJECT LENGTH FOR U-2707 DETERMINED BY USING -L-

Prepared in the Office of:

SEPI ENGINEERING GROUP
2300 Rexwoods Drive
Suite 370
Raleigh, NC 27607
Tel: 919-789-9977 Fax: 919-789-9591

2002 STANDARD SPECIFICATIONS

RIGHT OF WAY DATE:
FEBRUARY 18, 2005

LETTING DATE:
NOVEMBER 21, 2006

NCDOT CONTACT

HYDRAULICS ENGINEER

SIGNATURE: P.E.

ROADWAY DESIGN ENGINEER

SIGNATURE: P.E.

**DIVISION OF HIGHWAYS
STATE OF NORTH CAROLINA**

STATE DESIGN ENGINEER P.E.

**DEPARTMENT OF TRANSPORTATION
FEDERAL HIGHWAY ADMINISTRATION**

APPROVED DIVISION ADMINISTRATOR

DATE



STATE OF NORTH CAROLINA
DEPARTMENT OF TRANSPORTATION

P.O. BOX 25201, RALEIGH, N.C. 27611-5201

MICHAEL F. EASLEY
GOVERNOR

LYNDO TIPPETT
SECRETARY

November 15, 2004

State Project: 34438.1.1 (U-2707)
Federal Project:
County: Forsyth
Description: SR 3000 (Idols Road) from SR 2999 (Hampton Road) to US 158 (Clemmons Road)
Subject: Geotechnical Report - Inventory

Project Description

This is a report of an English-units geotechnical investigation for a project that extends Idols Road on a new alignment from Hampton Road where it now ends to a connection with Clemmons road. The inclusion of 5 Y lines, mostly paving, adds 2,681 feet to the project for a total length of 13,696 or 2.59 miles. The new road will be two lane with 4' paved shoulders. The following lines were investigated:

-L- Line:	11+52 to 121+67	11,015ft
-Y-:	9+95 to 25+02	1,607ft
-Y2-:	10+00 to 11+50	150ft
-Y3-	10+00 to 11+06	106ft
-Y4-	11+73 to 16+65	492ft
-Y5-	10+00 to 13+26	326ft

Areas of Special Geotechnical Interest

Highly Plastic Residual Soil

For the first mile of the project, residual A-7-5 or A-7-6 clayey soil with PI (Plasticity Index) values at 35 or greater is at the surface. We also found A-7-5 and A-7-6 residual soil with PI values greater than 25 in the final 2200' of -L-. The high PI intervals are listed below in the table.

Intervals of Highly Plastic Soil in Upper 10' of Section.

Interval	PI of Samples	Average PI
-L 15+93 to -L-34+00	36,41,38,35,35,38,39,37	37.3
-L-42+00 to -L-57+50	44,46,29,21,35,42,32,46,37,35,41,36,22	35.8
-L-100+00to-L-121+00	40,22,29,29,21,46,56,24,25,24,22,36,47, 30,22,45,27,27,35,32,34,30,46	32

Highly Plastic Alluvial Soil

From 73+50 to 82+50 there is a wedge up to 20' thick of alluvial, soft to medium stiff A-6 and A-7-6 clayey soil with blow counts as low as 2 and PI values as high as 35. A porous sand layer is beneath the clay. The profile shows 10 to 15 feet of fill in this area.

High Groundwater

Near surface groundwater was found in the Muddy Creek floodplain. The profile indicates an embankment up to 30' thick.

Interval	Soil Type	Fill or Cut
73+50 to 91+50	Alluvial Soil	20' to 30' fill

Wetlands

Wetlands identified on National Wetland Inventory occur south of the project corridor.

Physiography and Geology

The project is within the Piedmont physiographic province in the Charlotte Belt litho-tectonic province. This is a region of ridges at around 850' elevation and valley floors at around 700' elevation. The changes in elevation are accomplished gradually.

Topographic Setting

The roadway begins on a ridge top at an elevation of around 820. The natural ground gradually drops over the next mile, to the Muddy Creek floodplain at an elevation of about 690'. The floodplain is essentially flat and is 1700 feet wide at this point. Eventually the road climbs out of the floodplain and in 3100' rises to an elevation of 760'.

Drainage and Geomorphology

This region of North Carolina is within the Piedmont Physiographic Province.

Surface Drainage

The controlling river of the region is the Yadkin River. Muddy Creek is a tributary to the Yadkin, and has smaller named streams flowing into it. The Yadkin appears to be an entrenched meandering river and doesn't favor one direction above another. The second and third order streams including Muddy Creek and its tributaries generally line up as a lattice with either a northeast or northwest orientation.

Geomorphology

Geomorphology is the degree to which the shape of the landscape reflects the geology of the area. For some reason, it is uncommon in North Carolina to find much linkage between the existing topography and the subsurface geology. However, pre-existing rock characteristics probably account for the lattice drainage system. There is also a rise in the topography, seen in the profile from -L-68+00 to -L-73+00 that is matched in the subsurface by shallow rock.

Geology

The Geologic Map of the East Half of the Winston-Salem Quadrangle finds this project area underlain by Mafic Rock of the Charlotte Belt, (Pzcm). The clayey nature and consistency of the residual soil are consistent with a mafic intrusive rock.

Soil Properties

Soil samples results were classified using the AASHTO system for construction suitability and were described geologically and portrayed on the profiles attached to this report.

Engineering Properties

The quality analysis assigns each of the samples to an engineering classification. Most of the soil samples from this project are cohesive clay: A-7-6, A-7-5, A-6, A-2-5 with minor silt: A-5, A-4, and particularly near Muddy Creek, sand: A-2-4, A-3, and A-1.

Geological Properties

The project area covers an area of well-developed residual soil crossed by a stream and associated floodplain. The floodplain probably was formed during much earlier wetter days when Muddy Creek would have been Muddy River.

Soil Descriptions

Residual A-7-5, A-7-6

This clayey soil occurs in the upland area at the beginning and end of the project. It is at the surface everywhere but in the latter part of the project one 25 foot boring was A-7-5 throughout. PI values are from 20 to 50+ with liquid limit values above 50.

Residual A-6

A-6 soil is rare, appearing occasionally near sand or silt intervals.

Residual A-5, A-4, A-2-5, A-2-4

These more granular soil types are from below the clay soil and are less weathered. The increasing grain-size is a gradual transition to weathered rock.

Alluvial A-7 or A-6 Soil

This soil occurs in the floodplain, more on the southwest side than the northeast side. It is sandier than the residual soil with lower PI and Liquid Limit values. It is soft and with sand below in all cases, it is doubly drained.

Alluvial A-4, A-3, A-2-4

This soil is the lowermost material on the southwest side of the floodplain and the dominant material on the northeast half of the floodplain. It is often micaceous. It was found on a bedrock or weathered rock surface in most borings.

Rock Properties

We did not core and we did not see rock on this project. The weathered rock that we did see was greenish chloritic material consistent with the map designation of Mafic Charlotte Belt rock. Implied rock, (auger refusal) and weathered rock were limited to the Muddy Creek floodplain and the area immediately southwest at depths of 10 to 20 feet.

Groundwater Properties

There is groundwater within 10' of the ground surface in all of the floodplain borings, (-L-73+00 to -L-92+00). Borings at -L-92+45 and -L-98+50 are within a terrace deposit above the floodplain, and both show water. The source of this groundwater must be to the northeast and drains toward the floodplain.

Geotechnical Descriptive Analysis of the Project

The project was divided into 3 segments for discussion, based on subsurface geology. **Segment 1** is the -L- line from the beginning -L-11+52 to -L- 73+50. **Segment 2** covers the floodplain and is from -L-73+50 to -L-92+00. **Segment 3** is the upland at the end and runs from -L-92+00 to -L-121+66. The -Y- lines will be discussed with the adjacent section of -L-.

Segment 1. Station -L-11+52 to -L- 73+50, (Including -Y- Lines).

This segment is all on residual soil and covers the descent of the roadway down to the Muddy Creek Floodplain.

Physical Description

The alignment begins at the intersection of Hampton Road, (-Y-), and Idols Road (-L-), just north of the Norfolk Southern Railroad track. The project includes a new bridge over the railroad track and a section of new alignment of Hampton road connecting with the new bridge that will raise the grade and straighten a bend in Hampton Road a little. Idols road is moved to the north at the intersection, where it will cross Hampton Road at a controlled intersection to the new extension. The intersections of Armsburg Road, (-Y2-) to the north of Idols road, and Clementine Drive, (-Y3), to the south of the railroad track will be moved a little to join Hampton Road at the new location.

The road runs parallel to the railroad track, just off the right of way. The -L- alignment runs northwest from the intersection with Hampton road, elevation 815, then at -L-23+50, (elev. 810), it bends through a broad turn until at -L-37+50 it is at elevation 768 and running due east. A straight section carries it to -L-48+50, (elev. 763), where it enters a broad turn towards the north to -L- 60+75, (elev750), where it has gained a bearing of N29E. This segment ends at 73+50 and elevation 700.

Cuts and Fills

The significant (more than 5' thick) cuts and fills of this segment, are listed in the table below. Most of the segment will be built on fill. There is a little cut, and very little work on grade. The road will be built down the face of a slope so there will be little difference between the left and right side excavation activities.

Cut			Fill		
From	To		From	To	
			-L-17+50	-L-23+50	10' max
			-L-25+25	-L-44+00	10' to 15'
-L-44+25	-L-46+50	4' max			
			-L-48+50	-L-50+75	8' avg.
-L-53+50	-L-56+50	7' avg.			
-L-59+50	-L-60+50	10' max			
			-L-61+50	-L-62+25	7' max
			-L-66+00	-L-69+50	15' w/ culvert
-L-70+25	-L-72+258'	max			

Soil

This segment is on residual soil. There seems to be a progression with depth from A-7-5 to A-6 to A-4, A-2-4 and then weathered rock. The preliminary bridge boring on -Y- is contrary to this neat arrangement, and alternates between A-7-5 and A-5. Generally though, the PI decreases with depth as the blow count increases.

Highly Plastic Residual Soil

The A-7-5 with lesser A-7-6 is a surface unit with PI values from 25 to 46 and above and LL (liquid limit) values at 50 and above. There is a lot of variation in the composition but combined fine and coarse sand hangs around 30%.

Everything Else

From around 55+00 to the end of the segment A-4 and A-2-5, A-2-4 soil is found at shallow depth associated with increasing blow count values.

Pre-existing Fill Soil

No old fill soil was identified on this segment.

Rock

Weathered rock and implied rock were located below the topographic high from -L-70+00 to -L-72+50. We have no indication that this material will be encountered during construction activities.

Groundwater

No groundwater was identified on this segment.

Wetlands

No wetlands are portrayed on the National Wetland Inventory List on this segment.

Segment 2 from -L-73+50 to -L-92+00.

This segment crosses the Muddy Creek Floodplain and is underlain by alluvial soil.

Physical Description

This segment begins at elevation 695', goes through a gradual bend to N32E and continues on this bearing across a bridge to end the segment at 695' elevation.

Cuts and Fills

Then entire segment is on fill, increasing from 10' at the beginning of the segment to 20' at the end of the segment.

Soil

Alluvial Soil

The segment is underlain by a variety of alluvial soil deposits consistent with a floodplain depositional environment.

Gray and Tan, Soft to Medium Stiff, Wet A-7 Sandy Silty High Plasticity Clayey Alluvial Soil

This A-7 unit is found at the southwest side of the Muddy Creek floodplain. There is a buried topographic high between this soil and the current channel location, and it may be an abandoned channel. It is on alluvial sand so is doubly drained.

Gray, Tan and White Loose to Medium Dense Alluvial Sand, Silty Sand and Gravel.

This unit is found between -L-82+50 and the end of the project and returns AASHTO classifications of A-4, A-2-4, A-3, and A-1-B. It is a typical sand deposit associated with stream.

Soil Plasticity

Because fill on this section is at least 10' thick, no highly plastic soil is within 10' of finished grade. The interval of highly plastic soil that will underlie fill is listed below.

Location	Depth +or -	Soil Class	Thickness	Consistency	PI
-L-73+50, to 82+00	-0'	A-7,	10' - 15'	Soft to Stiff	24 to 39

Fill Soil

No fill soil was identified on this segment.

Groundwater

In every boring on this segment, groundwater was measured at less than 5' below ground surface. They borings appear to be hydraulically connected and controlled by Muddy Creek. It is likely that the southwestern borings in clayey soil are getting water from the basal aquifer that would be in slightly artesian conditions.

Wetlands

No wetland in the area was identified from the National Wetland Inventory, though one does appear slightly downstream and off the project.

Segment 3: -L-92+00 to -L-121+66.

This segment begins at the edge of the floodplain and covers -L- to the end. Up to -L- 98+50, (the first 500'), the segment is underlain by alluvial soil on a terrace, with the remainder on residual soil.

Physical Description

This segment begins at elevation 695' and climbs while travelling at N32E up to -L-105+50 where it begins a gradual curve to the north, to N4W, and 760' elevation. It drops slightly to the intersection with U.S.158 at elevation 747 where -L- ends. Clemmons Road to the left and right of the intersection is Y-4. The road will be improved for the intersection but the work will be on grade. Old Sides Mill Road is across Clemmons road and will receive paving, curb and gutter and other on grade work.

Cuts and Fills

The significant (more than 5' thick) cuts and fills of this segment, are listed in the table below.

Cut		Fill	
From	To	From	To
-L-115+00	-L-120+50	-L-92+00	-L-99+00
	5' - to 8'		15' to 5'

Soil

Alluvial -L-92+00 to -L-98+50

Alluvial A-6 and A-7 Sandy Silty Clay

A wedge-shaped section of A-6 clayey soil was found at the surface as part of the cover for a buried terrace. The terrace has a floor dipping back into the hill ending at elevation 690', (about 20' above the base of floodplain sed).

Alluvial A-2-4 and A-1-B

Below the clayey soil we found up to 10' of sand and gravel that provides a second drainage path most of the clayey soil.

Residual Soil -L-98+50 to -L-121+67

Residual A-7-5

As was the case in Segment 1, stiff to medium stiff, highly plastic residual A-7-5 clayey soil underlies this section.

Soil Plasticity

The intervals with PI values above 20 are listed below

Location	Fill or Cut	Soil Class	Thickness	Consistency
-L-96+00 to -L-98+50	Under 10' Fill	A-2-6	10'+	Stiff
-L-98+50 to -L-106+50	On Grade	A-7-5	10'+	Med. Stiff
-L-110+50 to -L-121+25	Under 8' Cut	A-7-5	10' +	Med. Stiff

Fill Soil

No fill soil sections were identified on this segment.

Groundwater

One of the borings in the perched terrace had water. Others to the same level were dry.

Wetlands

On the National Wetland Inventory, No wetlands were identified on this segment.

Closing Statement

If any significant changes are made in the design or location of the proposed roadway, the subsurface information and interpretations will have to be reviewed and modified as necessary.

Respectfully Submitted,

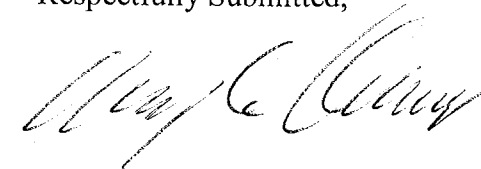

R.Q. Callaway

Project Geologist

DATUM DESCRIPTION
 THE LOCALIZED COORDINATE SYSTEM DEVELOPED FOR THIS PROJECT IS BASED ON THE STATE PLANE COORDINATES ESTABLISHED BY NCOT FOR MONUMENT "U2701-1" WITH NAD 1983/95 STATE PLANE GRID COORDINATES OF NORTHING: 82198892.1(1) EASTING: 1592508.187(1) THE AVERAGE COMBINED GRID FACTOR USED ON THIS PROJECT (GROUND TO GRID) IS: 0.99992463 THE N.C. LAMBERT GRID BEARING AND LOCALIZED HORIZONTAL GROUND DISTANCE FROM "U2701-1" TO -L- STA.10+00.00 IS N 51° 22' 18" E FOR 11326439 FEET ALL LINEAR DIMENSIONS ARE LOCALIZED HORIZONTAL DISTANCES VERTICAL DATUM USED IS NAVD 88

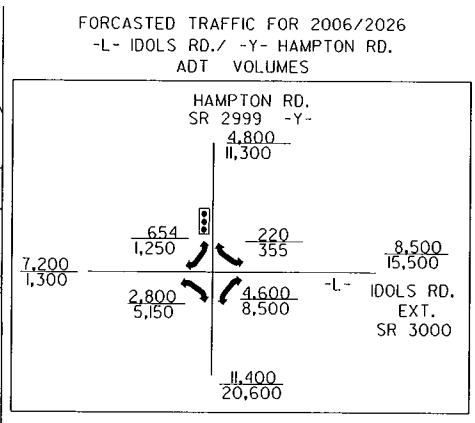
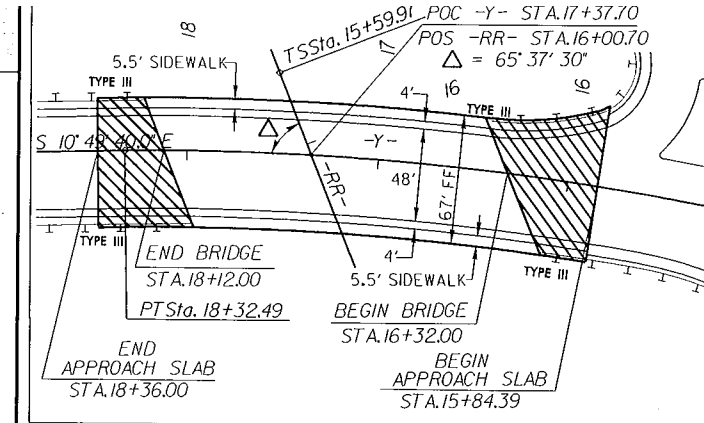

Sketch showing Dimensions of Pavement and Shoulder in Relation to Proposed Bridge Width for -Y- over Railroad

-L-

PI Sta 13+25.43 Δ = 16° 26' 34.7" (LT) D = 4' 46' 28.7" L = 344.38' T = 173.38' R = 1,200.00' SE = .06	PIs Sta 15+46.45 Δs = 3' 34' 51.6" Ls = 150.00' LT = 100.02' ST = 50.02'	PIs Sta 17+46.47 Δs = 5' 08' 46.8" Ls = 150.00' LT = 100.04' ST = 50.04'
PI Sta 18+97.07 Δ = 13° 44' 42.1" (RT) D = 6' 51' 42.4" L = 200.31' T = 100.64' R = 835.00' SE = .06	PI Sta 24+47.09 Δ = 15° 07' 44.9" (LT) D = 3' 49' 11.0" L = 396.08' T = 199.20' R = 1,500.00' SE = .06	

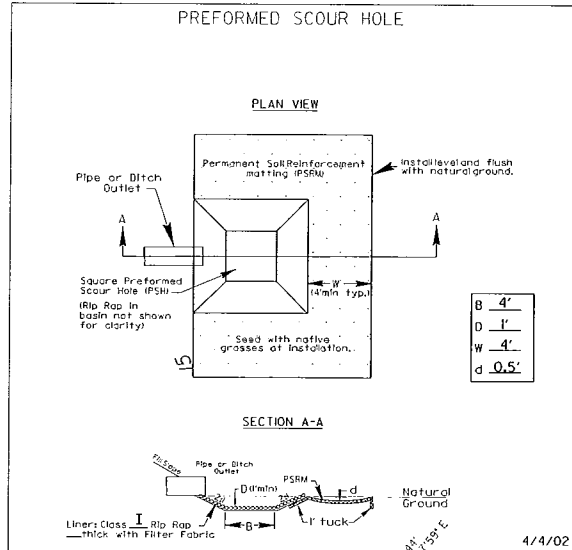

TYPICAL QUANTITIES FOR PREFORMED SCOUR HOLES 1-7

EST. 36.7 TONS CL 1 RR	SR Sta. 16+46.43
EST. 57.0 CY DDE	POT Sta. 10+00.00 -DRI-
EST. 108.5 SY PSM	
EST. 52.2 SY FILTER FABRIC	

BEGIN PROJECT U-2707
 POT Sta.11+52.05 -L-

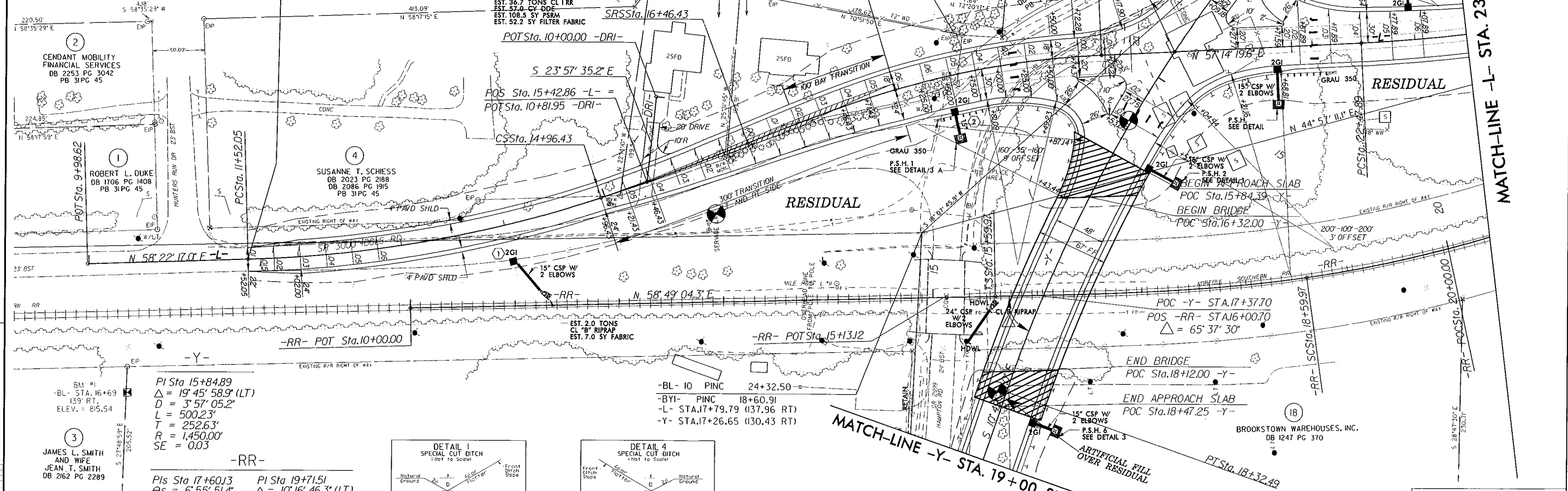

-RR-

BM #1 -BL- STA. 16+69 139' RT. ELEV. = 815.54	PI Sta 15+84.89 Δ = 19° 45' 58.9" (LT) D = 3' 57' 05.2" L = 500.23' T = 252.63' R = 1,450.00' SE = 0.03	PIs Sta 17+60J3 Δs = 6' 55' 51.4" Ls = 300.00' LT = 200J5' ST = 100J4'	PIs Sta 19+71.51 Δ = 10° 16' 46.3" (LT) D = 4' 37' 14.3" L = 222.47' T = 111.53' R = 1,240.00'
--	---	--	---

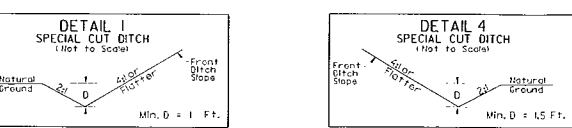

-Y- STA. 12+00 TO -Y- STA. 14+00
 -Y- STA. 22+96 LT TO -Y- STA. 23+50 LT
 -Y- STA. 18+00 RT TO -Y- STA. 19+00 RT

MATCH-LINE -Y- STA. 19+00 SEE SHEET 13

FOR -L- PROFILE, SEE SHEET 14
 FOR -Y- PROFILE, SEE SHEET 18
 FOR -Y2- PROFILE, SEE SHEET 19

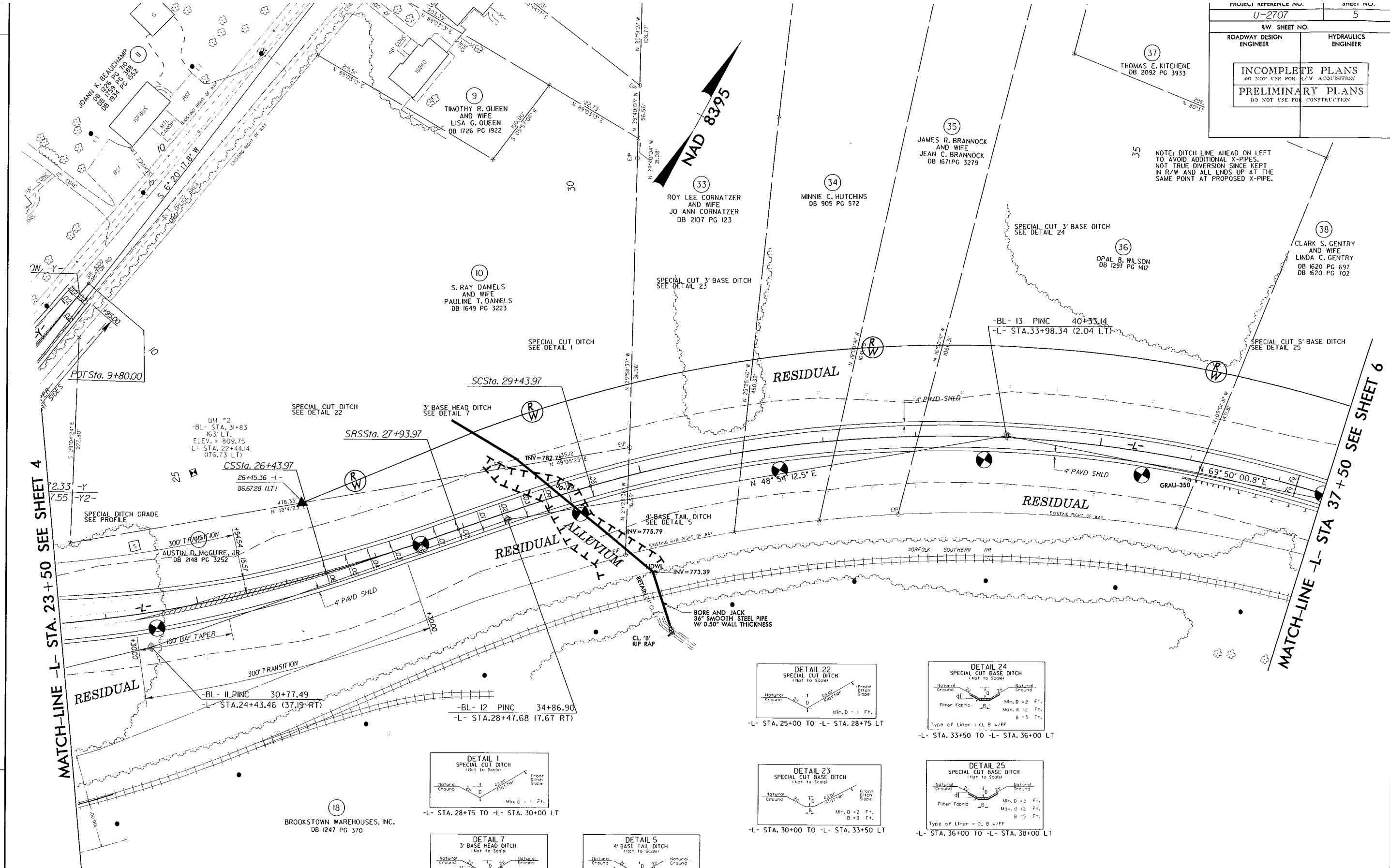

NOTE: DITCH LINE AHEAD ON LEFT TO AVOID ADDITIONAL X-PIPES. NOT TRUE DIVERSION SINCE KEPT IN R/W AND ALL ENDS UP AT THE SAME POINT AT PROPOSED X-PIPE.

MATCH-LINE -L- STA. 23+50 SEE SHEET 4

MATCH-LINE -L- STA. 37+50 SEE SHEET 6

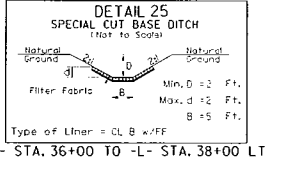
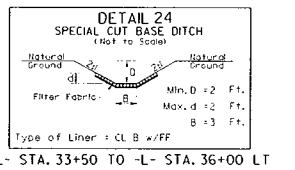
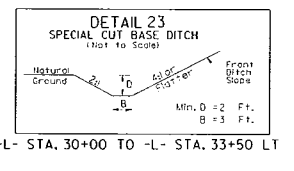
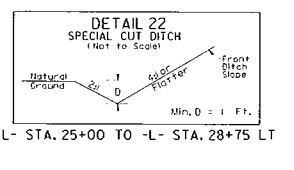
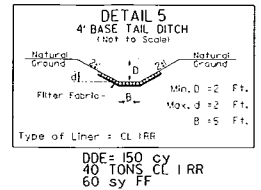
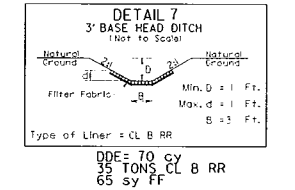
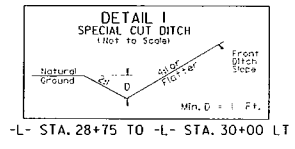

PI Sta 24+47.09 Δ = 15° 07' 44.9" (LT) D = 3' 49' 11.0" L = 396.08' T = 199.20' R = 1,500.00' SE = 0.06	PIs Sta 26+93.98 Θs = 2° 51' 53.2" Ls = 150.00' LT = 100.01' ST = 50.01'	PIs Sta 28+93.99 Θs = 3° 07' 30.8" Ls = 150.00' LT = 100.02' ST = 50.01'	PI Sta 33+81.20 Δ = 35° 16' 48.5" (RT) D = 4' 10' 01.1" L = 846.66' T = 437.23' R = 1,375.00' SE = 0.06
---	--	--	---

FOR PROFILE, SEE SHEET 14

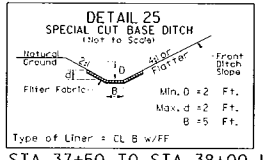

-L- STA. 37+50 TO STA. 38+00 LT

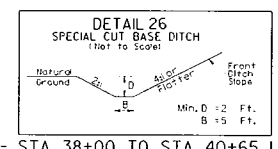

-L- STA. 38+00 TO STA. 40+65 LT

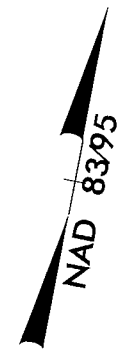

38
CLARK S. GENTRY AND WIFE
LINDA C. GENTRY
DB 1620 PG 697
DB 1620 PG 702

39
OPAL B. WILSON
DB 1297 PG 1404
DB 1297 PG 1406

40
EDNA W. BINGHAM
DB 786 PG 441

MATCH-LINE -L- STA 37+50 SEE SHEET 5

MATCH-LINE -L- STA 51+50 SEE SHEET 7

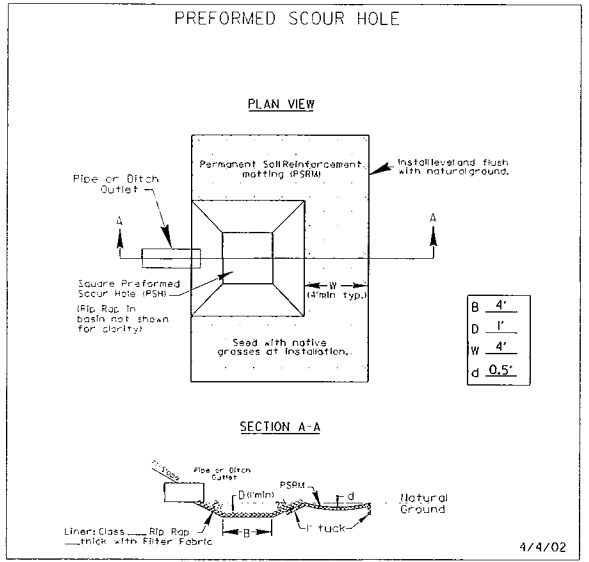
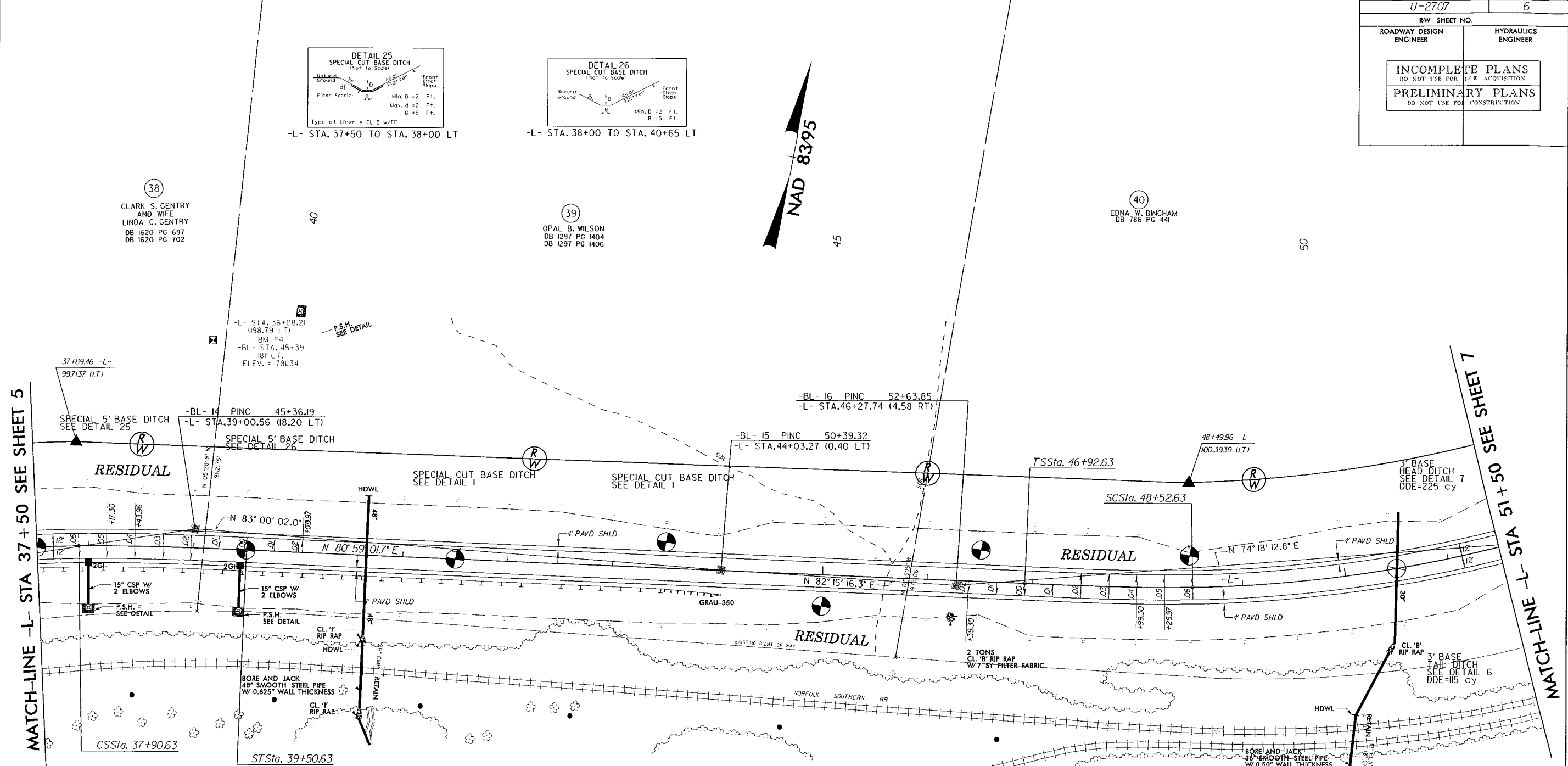

36.7 TONS CL I
57.0 cy DDE
108.5 sy PSRM
52.2 sy FF

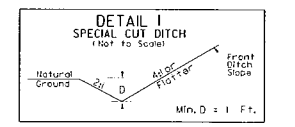

-L- STA. 40+65 TO STA. 42+50 LT
-L- STA. 43+00 TO STA. 44+00 LT
-L- STA. 48+50 TO STA. 50+60 LT
-L- STA. 50+60 TO STA. 51+50 LT

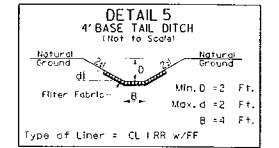

20 TONS CL I
35 sy FF

-L-

Pls Sta 38+43.98	Pls Sta 47+99.32	Pls Sta 53+94.10
$\theta_s = 3^\circ 20' 00.9''$	$\theta_s = 3^\circ 26' 46.9''$	$\Delta = 44^\circ 18' 15.0''$ (LT)
$L_s = 160.00'$	$L_s = 160.00'$	$D = 4' 18' 28.6''$
$LT = 106.69'$	$LT = 106.69'$	$L = 1,028.43'$
$ST = 53.35'$	$ST = 53.35'$	$T = 541.47'$
		$R = 1,330.00'$
		$SE = 0.06$

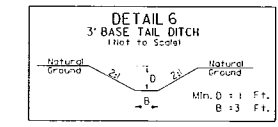

DDE = 115 cy

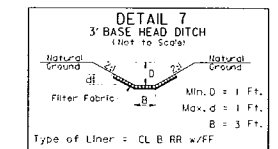

20 TONS CL B RR
50 sy FF
DDE = 225 cy

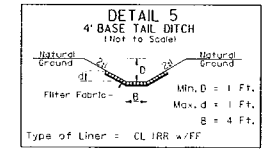

12 TONS CL I RR
15 sy FF
DDE = 220 cy

NOTE: TAIL DITCH EXTENDED TO RR X-PIPE SINCE NEW PIPE HAS TO BE BORE & JACKED UNDER THE RR.

4' BASE TAIL DITCH
SEE DETAIL 5
DDE=220 cy
TIE TO EXISTING

FOR PROFILE, SEE SHEET 14 & 15

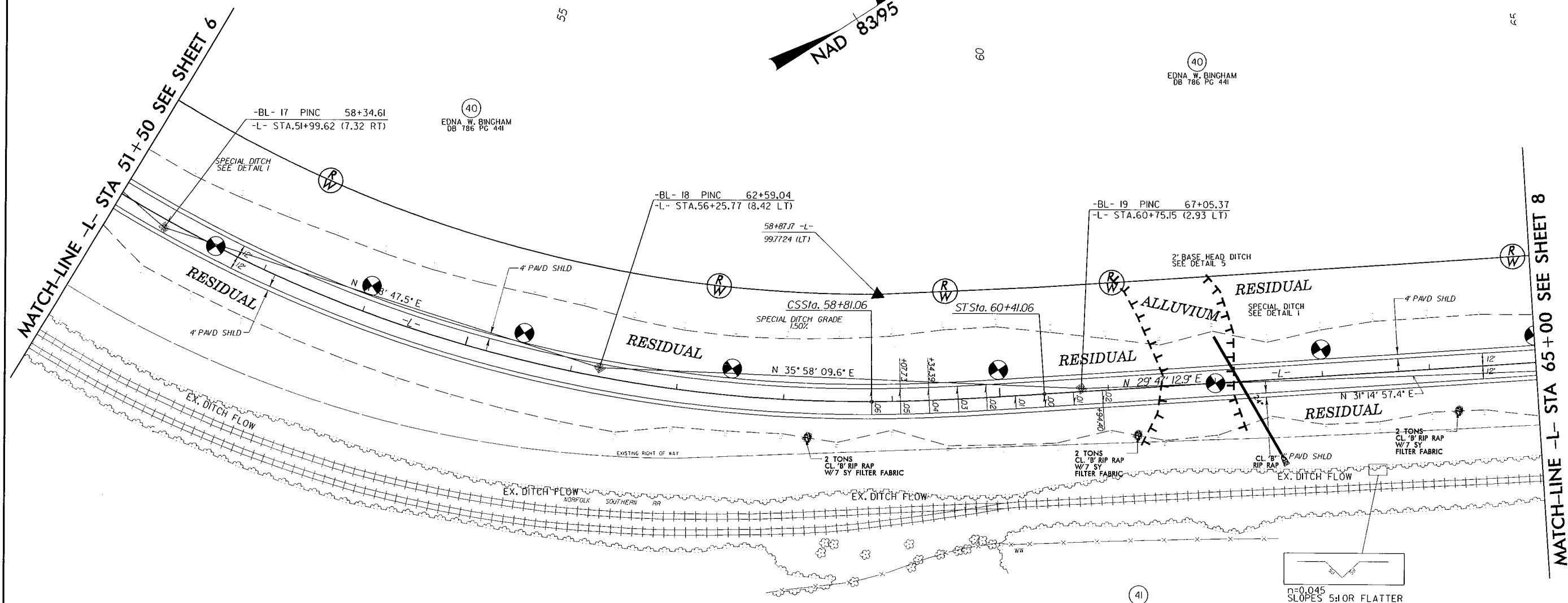
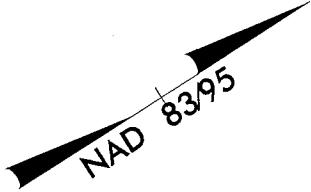

BM #5
-BL- STA. 64+85
343' LT.
ELEV. = 718.74
-L- STA. 55+46.53
(319.40 RT)

DETAIL 1
SPECIAL CUT DITCH
1:1 to Slope

Min. D = 1 Ft.

-L- STA. 51+50 TO -L- STA. 52+50 LT
-L- STA. 59+50 TO -L- STA. 62+00 LT
-L- STA. 62+00 TO -L- STA. 63+00 LT

DETAIL 8
2' BASE HEAD DITCH
1:1 to Slope

Min. D = 1 Ft., B = 2 Ft.

DDE = 20 cy

FOR PROFILE, SEE SHEET 15

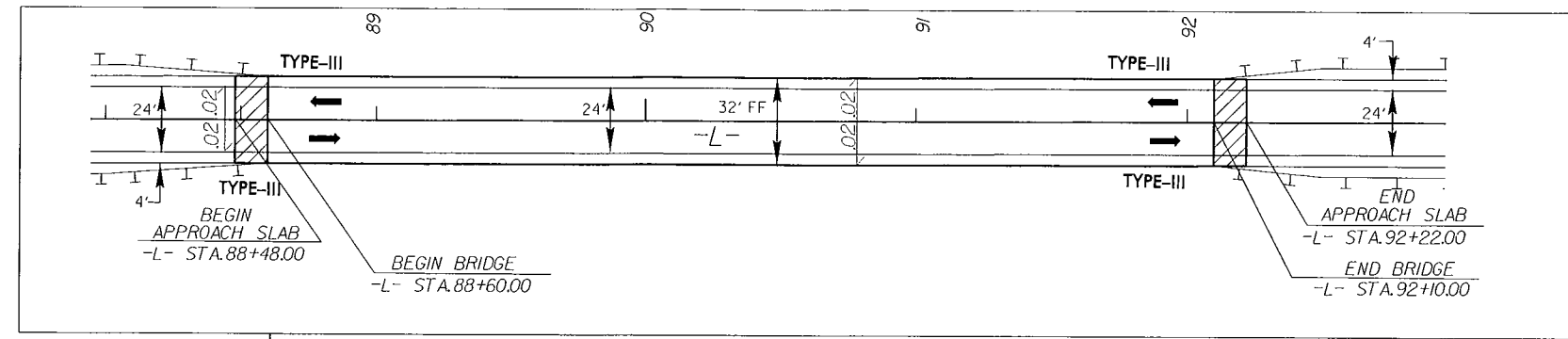
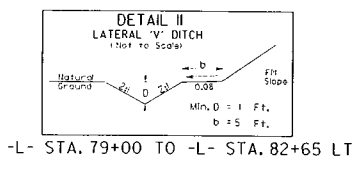

Sketch showing Dimensions of Pavement and Shoulder in Relation to Proposed Bridge Width

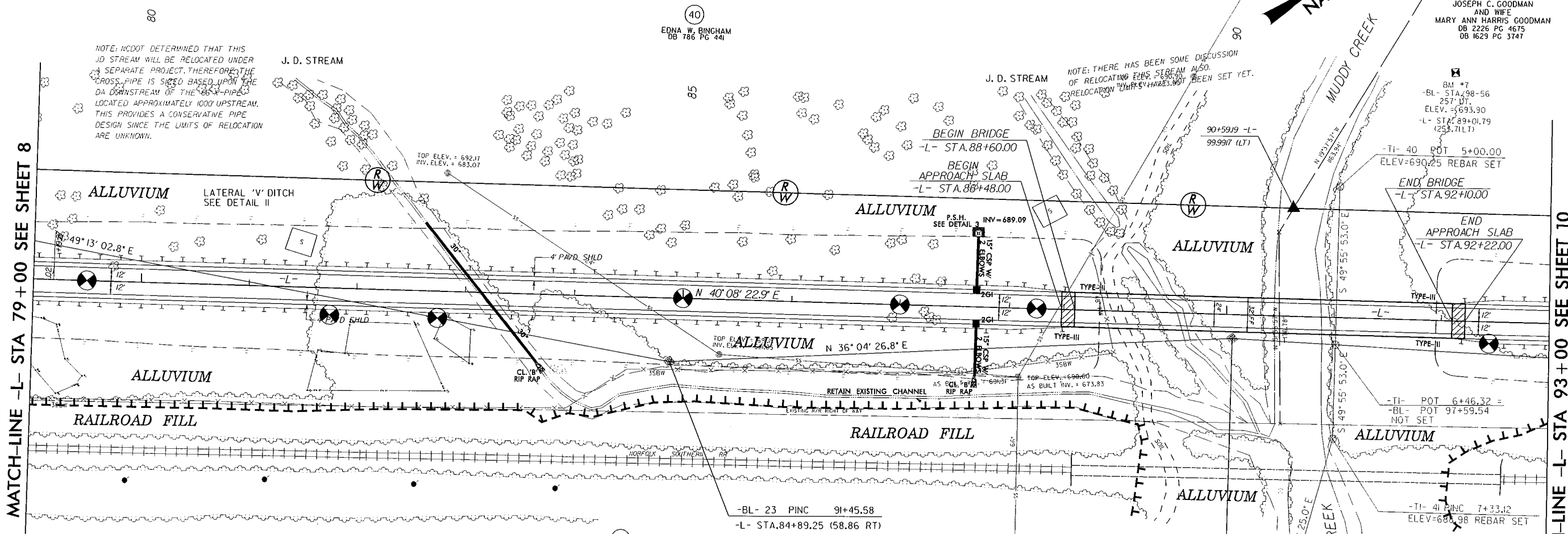

MATCH-LINE -L- STA 79+00 SEE SHEET 8

MATCH-LINE -L- STA 93+00 SEE SHEET 10

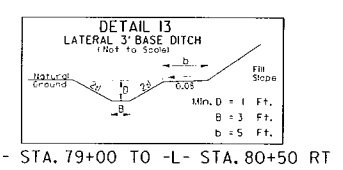

-L- STA. 79+00 TO -L- STA. 80+50 RT

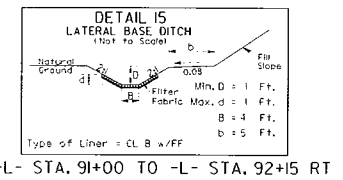

-L- STA. 91+00 TO -L- STA. 92+15 RT

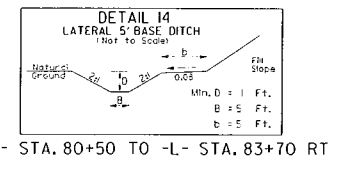

-L- STA. 80+50 TO -L- STA. 83+70 RT

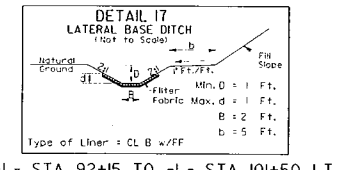

-L- STA. 92+15 TO -L- STA. 101+50 LT
 -L- STA. 92+15 RT TO STA. 100+50 RT

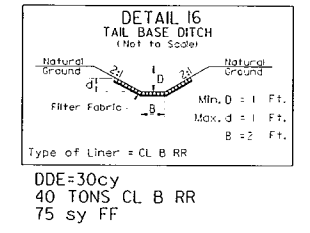
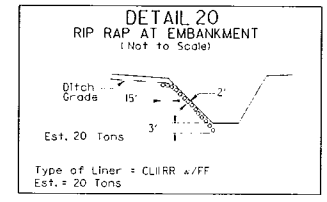
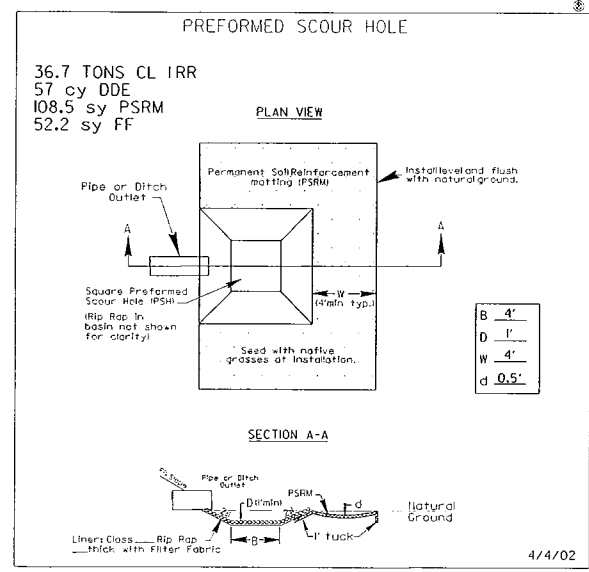

FOR PROFILE, SEE SHEET 16

PROJECT REFERENCE NO. U-2707	SHEET NO. 10
RW SHEET NO.	
ROADWAY DESIGN ENGINEER	HYDRAULICS ENGINEER
INCOMPLETE PLANS DO NOT USE FOR R/W ACQUISITION	
PRELIMINARY PLANS DO NOT USE FOR CONSTRUCTION	

(42)
JOSEPH C. GOODMAN
AND WIFE
MARY ANN HARRIS GOODMAN
DB 2226 PG 4675
DB 1629 PG 3747

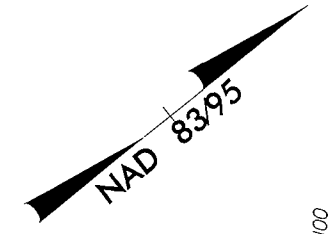

95

100

105

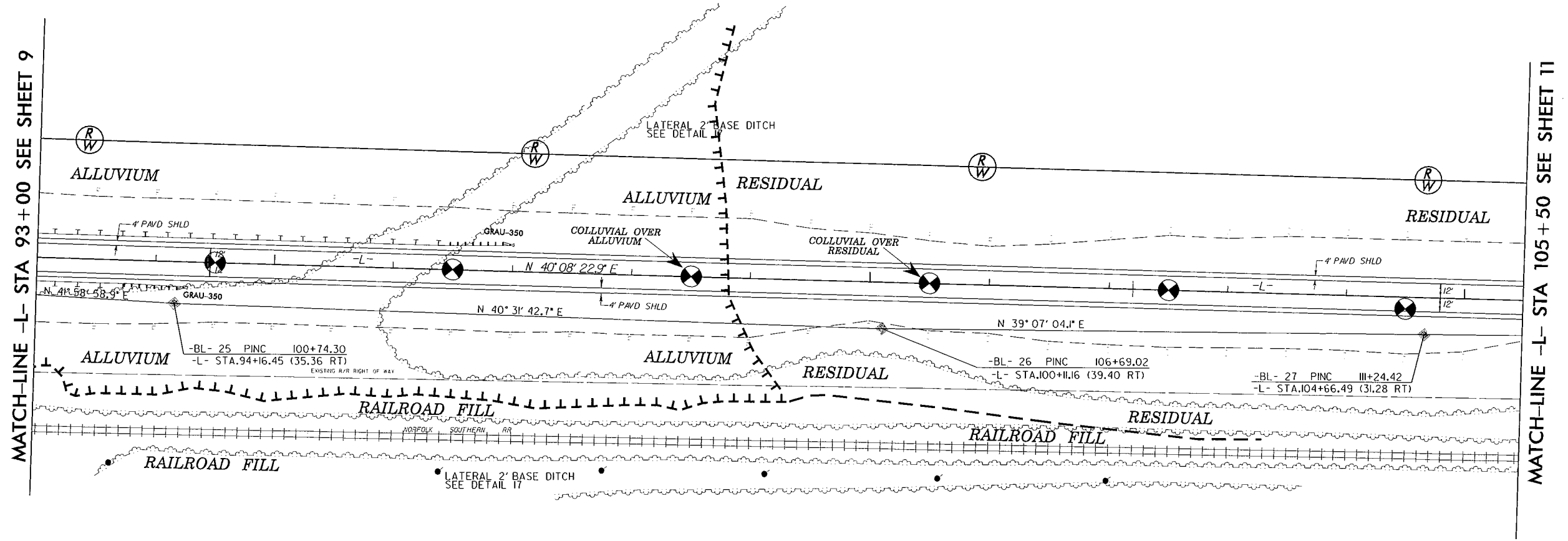

MATCH-LINE -L- STA 93+00 SEE SHEET 9

MATCH-LINE -L- STA 105+50 SEE SHEET 11

REVISIONS

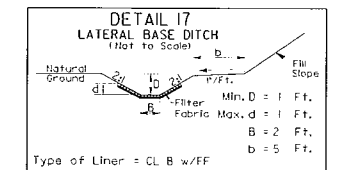

-L- STA. 92+00 TO -L- STA. 101+50 LT
-L- STA. 92+00 TO -L- STA. 100+50 RT

FOR PROFILE, SEE SHEET 16 & 17

SEPI ENGINEERING GROUP
2300 Roxwoods Drive
Suite 370
Raleigh, NC 27607
Tel: 919-789-3971 Fax: 919-789-9591

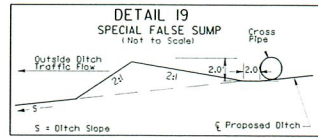

-L- STA. 106+60 LT

BM #8
 -BL- STA. 119+65
 445 LT.
 ELEV. = 751.53
 -L- STA. 109+79.59
 (466.04 LT)

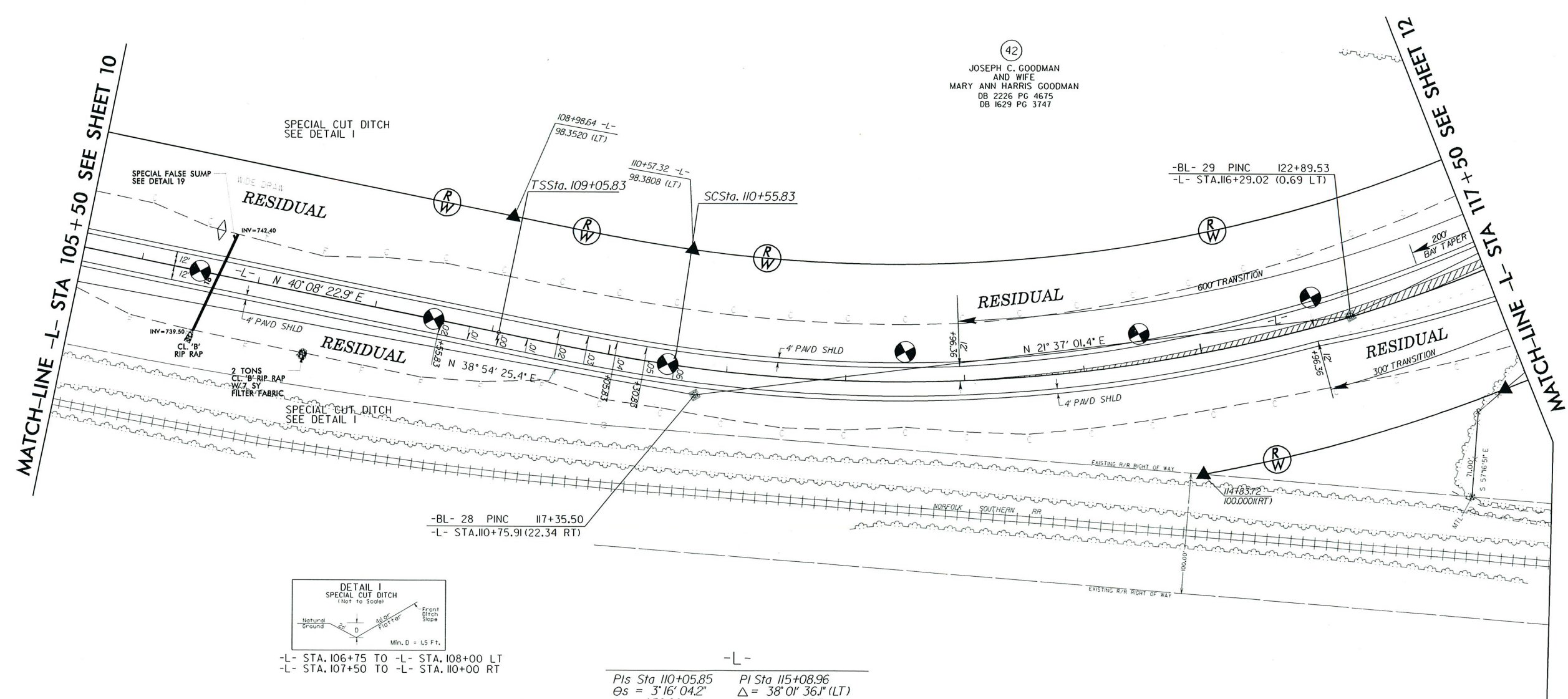

42
 JOSEPH C. GOODMAN
 AND WIFE
 MARY ANN HARRIS GOODMAN
 DB 2226 PG 4675
 DB 1629 PG 3747

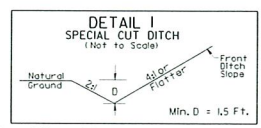

-L- STA. 106+75 TO -L- STA. 108+00 LT
 -L- STA. 107+50 TO -L- STA. 110+00 RT

-L-
 PIs Sta 110+05.85 PI Sta 115+08.96
 $\Theta_s = 3' 16'' 04.2''$ $\Delta = 38' 01'' 36.1''$ (LT)
 $L_s = 150.00'$ $D = 4' 21'' 25.5''$
 $LT = 100.02'$ $L = 872.75'$
 $ST = 50.02'$ $T = 453.13'$
 $R = 1,315.00'$
 $SE = 0.06$

REVISIONS

DATE: TIME: DRAWN BY: CHECKED BY: DATE: TIME: DRAWN BY: CHECKED BY:

FOR PROFILE, SEE SHEET 17

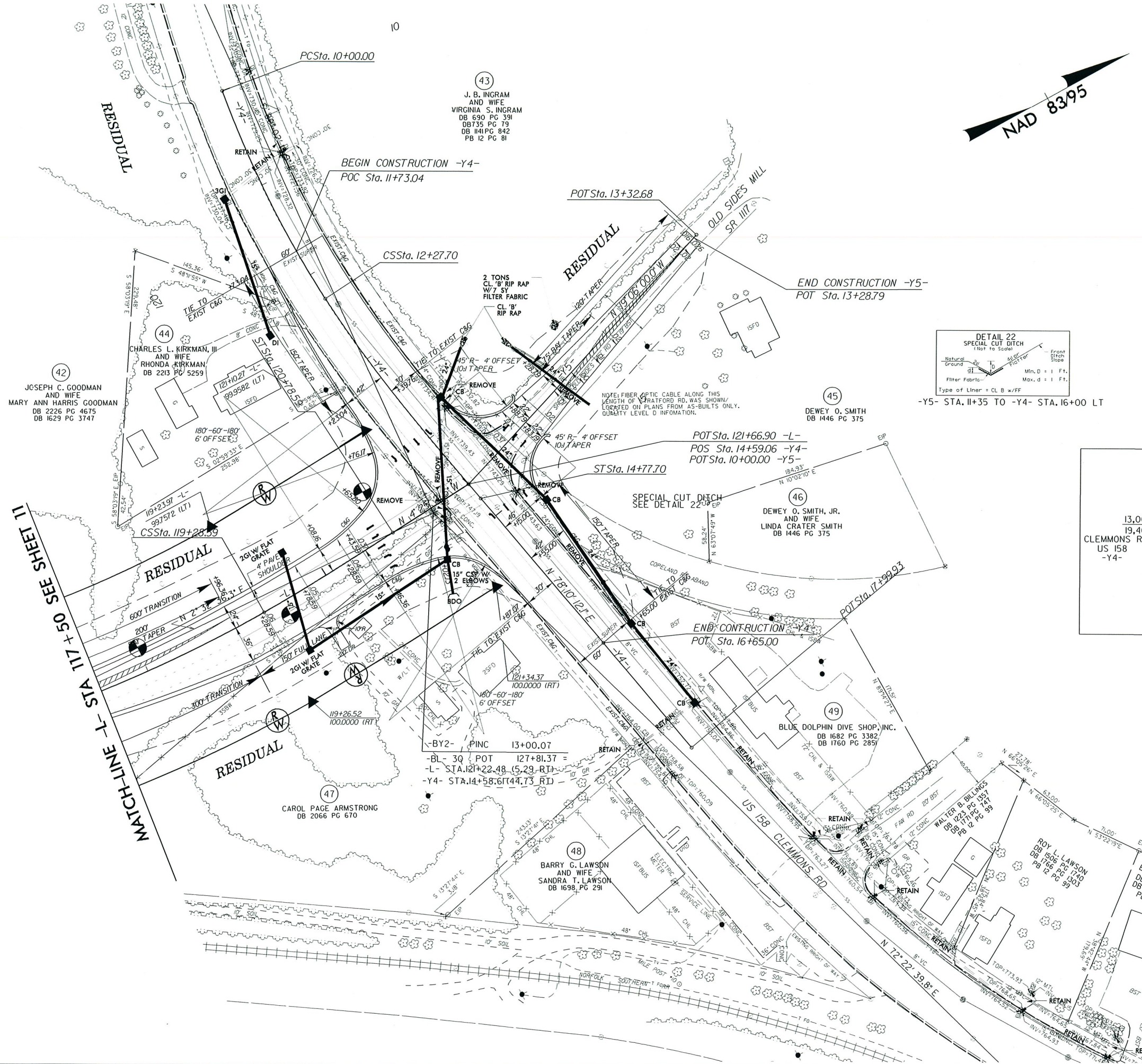

-Y4-

PI Sta 11+4.33 Δ = 12' 47" 26.1" (LT) D = 5' 37" 02.0" L = 227.70 T = 114.33' R = 1,020.00' SE = EXIST.	PIs Sta 13+11.6 Θs = 7' 01" 17.5" Ls = 250.00' LT = 166.80' ST = 83.45' SE = EXIST.
---	--

-L-

PI Sta 115+08.96 Δ = 38' 01" 36.1" (LT) D = 4' 21" 25.5" L = 872.75 T = 453.13' R = 1,315.00' SE = 0.06	PIs Sta 119+78.60 Θs = 3' 16" 04.2" Ls = 150.00' LT = 100.02' ST = 50.02'
---	---

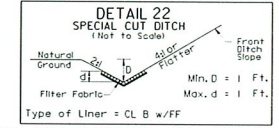

-Y5- STA. 11+35 TO -Y4- STA. 16+00 LT

FORCASTED TRAFFIC FOR 2006/ 2026
-L- IDOLS RD./ -Y4- CLEMMONS RD.
ADT VOLUMES

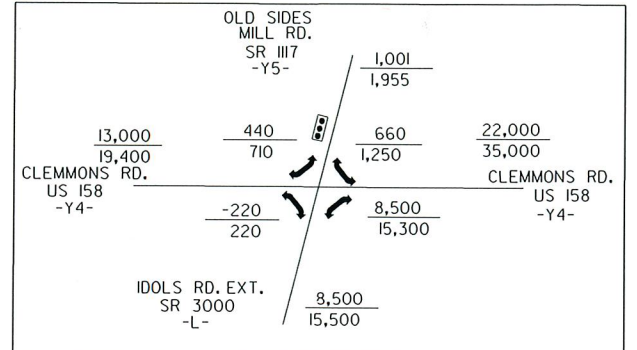

FOR -L- PROFILE, SEE SHEET 17
FOR -Y4- PROFILE, SEE SHEET 20
FOR -Y5- PROFILE, SEE SHEET 20

REVISIONS

DATE: _____
TIME: _____
BY: _____

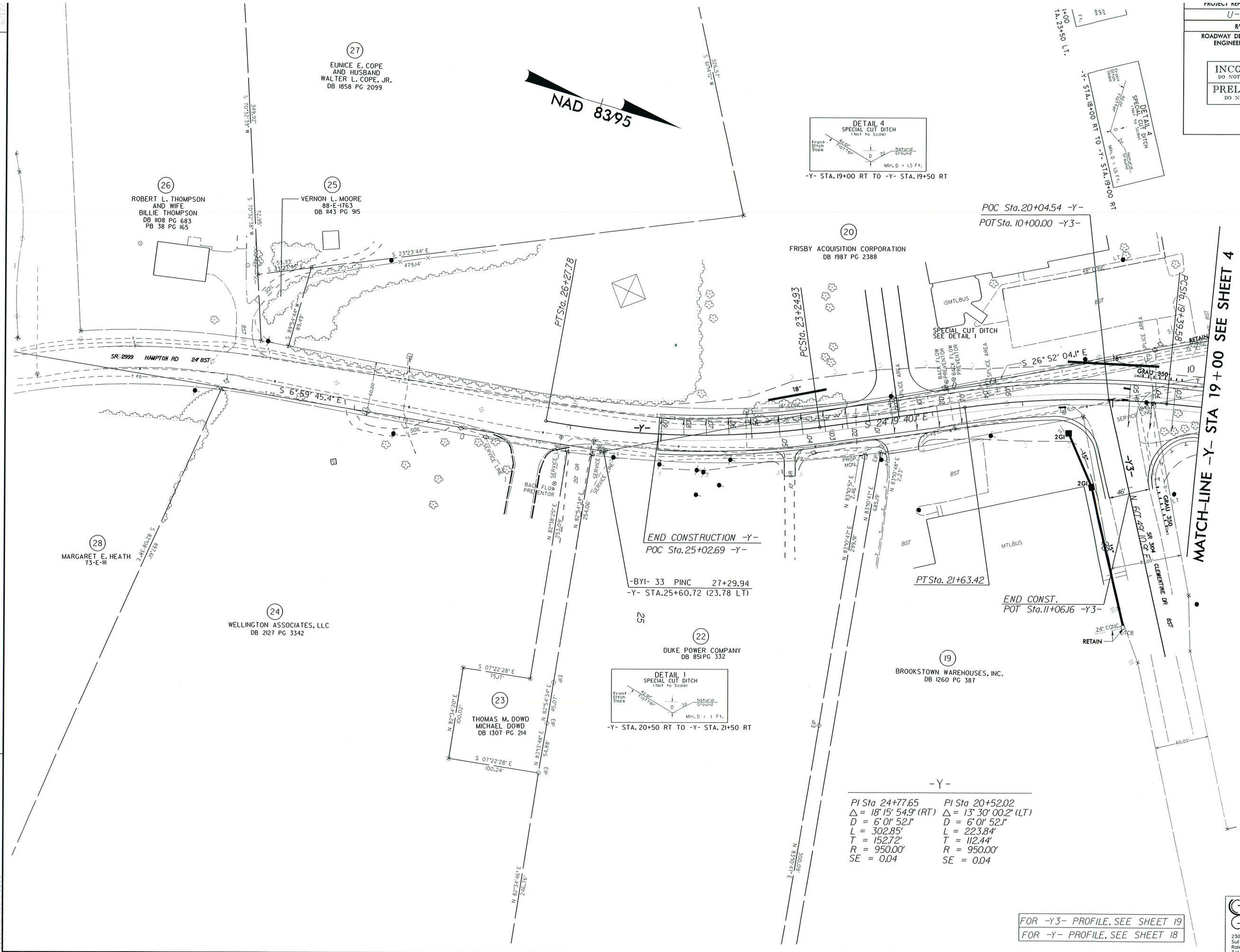
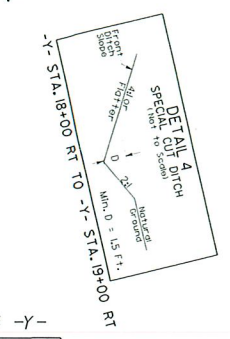
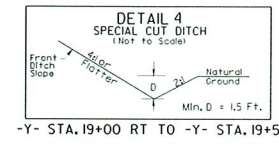
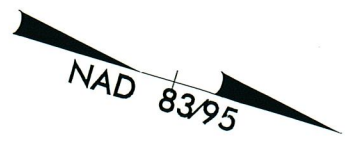

27 EUNICE E. COPE AND HUSBAND WALTER L. COPE, JR. DB 1858 PG 2099

26 ROBERT L. THOMPSON AND WIFE BILLIE THOMPSON DB 1108 PG 683 PB 38 PG 165

25 VERNON L. MOORE 88-E-1763 DB 1143 PG 915

20 FRISBY ACQUISITION CORPORATION DB 1987 PG 2388

POC Sta. 20+04.54 -Y-
 POT Sta. 10+00.00 -Y3-

28 MARGARET E. HEATH 73-E-III

24 WELLINGTON ASSOCIATES, LLC DB 2127 PG 3342

23 THOMAS M. DOWD MICHAEL DOWD DB 1307 PG 214

END CONSTRUCTION -Y-
 POC Sta. 25+02.69 -Y-

-BYI- 33 PINC 27+29.94
 -Y- STA. 25+60.72 (23.78 LT)

22 DUKE POWER COMPANY DB 851 PG 332

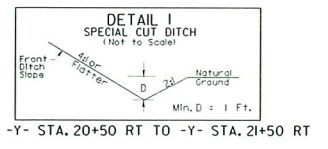

19 BROOKSTOWN WAREHOUSES, INC. DB 1260 PG 387

-Y-
 PI Sta 24+77.65 PI Sta 20+52.02
 $\Delta = 18' 15'' 54.9''$ (RT) $\Delta = 13' 30'' 00.2''$ (LT)
 $D = 6' 01'' 52.1''$ $D = 6' 01'' 52.1''$
 $L = 302.85'$ $L = 223.84'$
 $T = 152.72'$ $T = 112.44'$
 $R = 950.00'$ $R = 950.00'$
 $SE = 0.04$ $SE = 0.04$

MATCH-LINE -Y- STA 19+00 SEE SHEET 4

FOR -Y3- PROFILE, SEE SHEET 19
 FOR -Y- PROFILE, SEE SHEET 18

REVISIONS

DATE: _____ TIME: _____
 BY: _____ FOR: _____

INCOMPLETE PLANS
DO NOT USE FOR ACQUISITION
PRELIMINARY PLANS
DO NOT USE FOR CONSTRUCTION

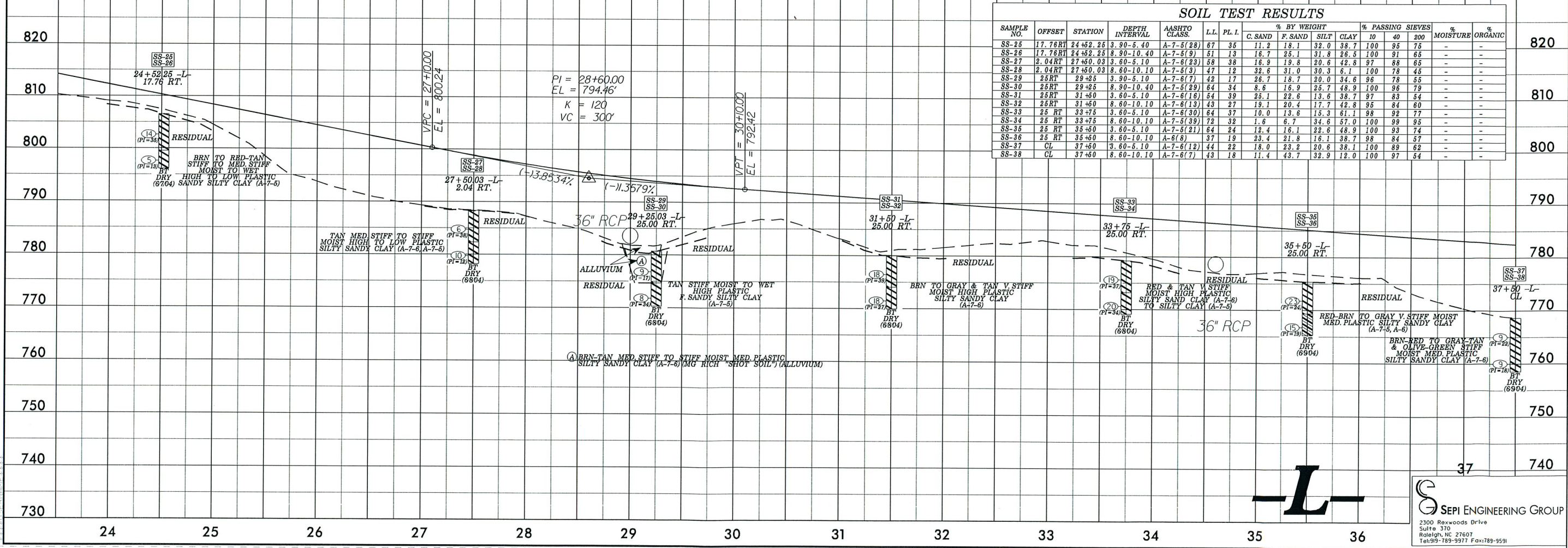
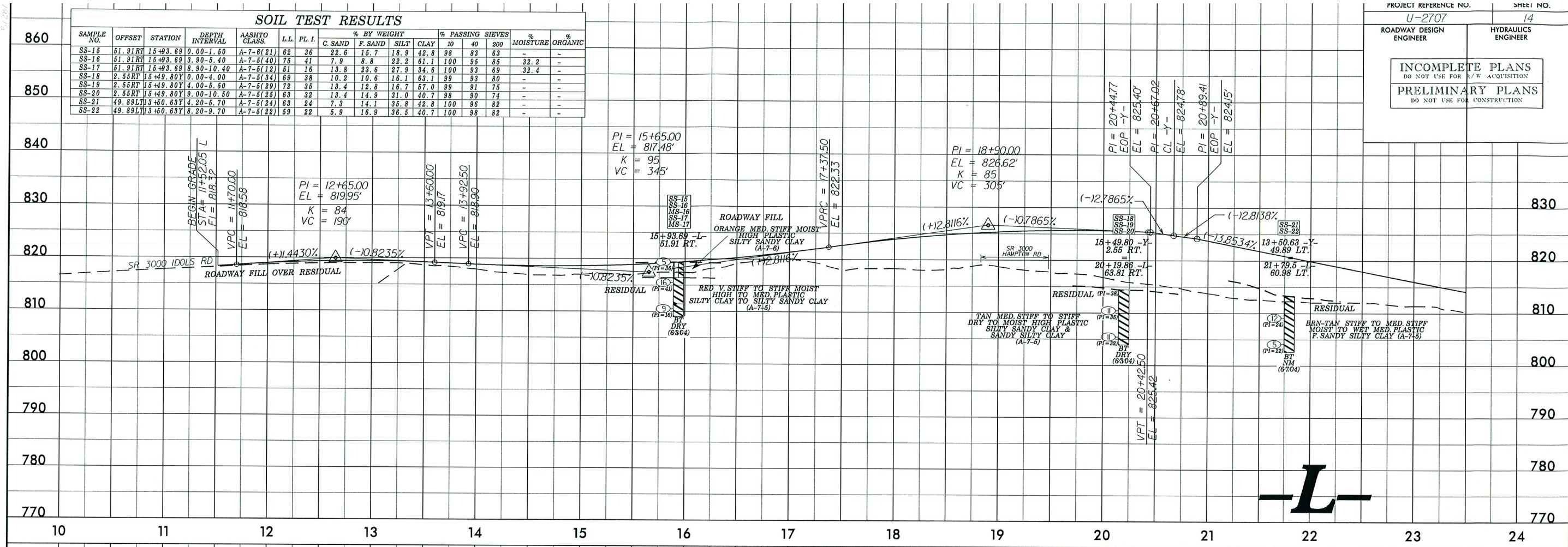

SOIL TEST RESULTS

SAMPLE NO.	OFFSET	STATION	DEPTH INTERVAL	AASHTO CLASS.	L.L.	P.L.I.	% BY WEIGHT				% PASSING SIEVES			% MOISTURE	% ORGANIC
							C. SAND	F. SAND	SILT	CLAY	10	40	200		
SS-15	51.91 RT	15+93.69	0.00-1.50	A-7-6(21)	62	36	22.6	15.7	18.9	42.8	98	83	63	-	-
SS-16	51.91 RT	15+93.69	3.90-5.40	A-7-5(40)	75	41	7.9	8.8	22.2	61.1	100	95	85	32.2	-
SS-17	51.91 RT	15+93.69	8.90-10.40	A-7-5(12)	61	16	13.8	23.6	27.9	34.6	100	93	69	32.4	-
SS-18	2.55 RT	15+49.80 Y	0.00-4.00	A-7-5(34)	69	38	10.2	10.6	16.1	63.1	99	93	80	-	-
SS-19	2.55 RT	15+49.80 Y	4.00-5.50	A-7-5(29)	72	35	13.4	12.8	16.7	57.0	99	91	75	-	-
SS-20	2.55 RT	15+49.80 Y	9.00-10.50	A-7-5(25)	63	32	13.4	14.9	31.0	40.7	98	90	74	-	-
SS-21	49.89 LT	13+60.63 Y	4.20-5.70	A-7-5(24)	63	24	7.3	14.1	35.8	42.8	100	96	82	-	-
SS-22	49.89 LT	13+60.63 Y	8.20-9.70	A-7-5(22)	59	22	5.9	16.9	36.5	40.7	100	98	82	-	-

SOIL TEST RESULTS

SAMPLE NO.	OFFSET	STATION	DEPTH INTERVAL	AASHTO CLASS.	L.L.	P.L.I.	% BY WEIGHT				% PASSING SIEVES			% MOISTURE	% ORGANIC
							C. SAND	F. SAND	SILT	CLAY	10	40	200		
SS-25	17.76 RT	24+52.25	3.90-5.40	A-7-5(28)	67	35	11.2	18.1	32.0	38.7	100	95	75	-	-
SS-26	17.76 RT	24+52.25	8.90-10.40	A-7-5(9)	51	13	16.7	25.1	31.8	26.5	100	91	65	-	-
SS-27	2.04 RT	27+50.03	3.60-5.10	A-7-6(23)	58	38	16.9	19.8	20.6	42.8	97	88	65	-	-
SS-28	2.04 RT	27+50.03	8.60-10.10	A-7-5(3)	47	12	32.6	31.0	30.3	6.1	100	78	45	-	-
SS-29	25 RT	29+25	3.90-5.10	A-7-5(7)	49	17	26.7	18.7	20.0	34.6	96	78	55	-	-
SS-30	25 RT	29+25	8.90-10.40	A-7-5(29)	64	34	8.6	15.9	25.7	48.9	100	96	79	-	-
SS-31	25 RT	31+50	3.60-5.10	A-7-6(16)	54	39	25.1	22.6	13.6	38.7	97	83	54	-	-
SS-32	25 RT	31+50	8.60-10.10	A-7-6(13)	43	27	18.1	20.4	17.7	42.8	95	84	60	-	-
SS-33	25 RT	33+75	3.60-5.10	A-7-6(30)	64	37	10.0	13.6	15.3	61.1	98	92	77	-	-
SS-34	25 RT	33+75	8.60-10.10	A-7-5(39)	72	32	1.6	6.7	34.6	57.0	100	99	95	-	-
SS-35	25 RT	35+50	3.60-5.10	A-7-5(21)	64	24	12.4	16.1	22.6	48.9	100	93	74	-	-
SS-36	25 RT	35+50	8.60-10.10	A-6(8)	37	19	23.4	21.8	16.1	38.7	98	84	57	-	-
SS-37	CL	37+50	3.60-5.10	A-7-6(12)	44	22	18.0	23.2	20.6	38.1	100	89	62	-	-
SS-38	CL	37+50	8.60-10.10	A-7-6(7)	43	18	11.4	43.7	32.9	12.0	100	97	54	-	-

L

L

INCOMPLETE PLANS
DO NOT USE FOR R/W ACQUISITION
PRELIMINARY PLANS
DO NOT USE FOR CONSTRUCTION

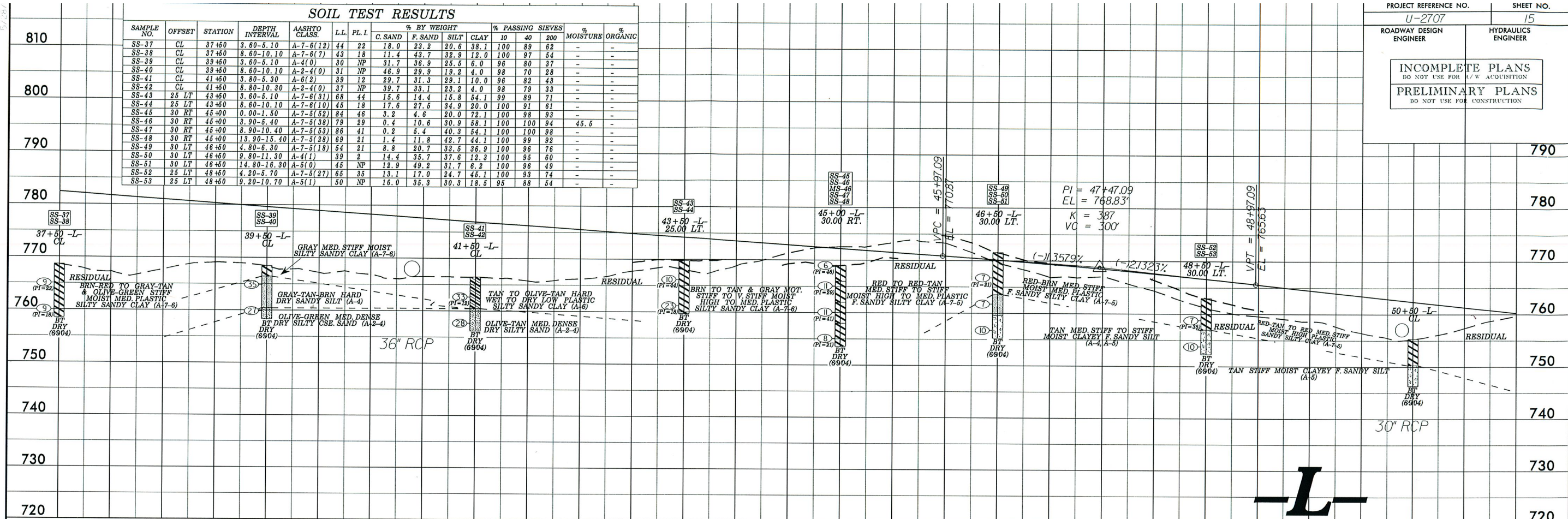

38 39 40 41 42 43 44 45 46 47 48 49 50 51

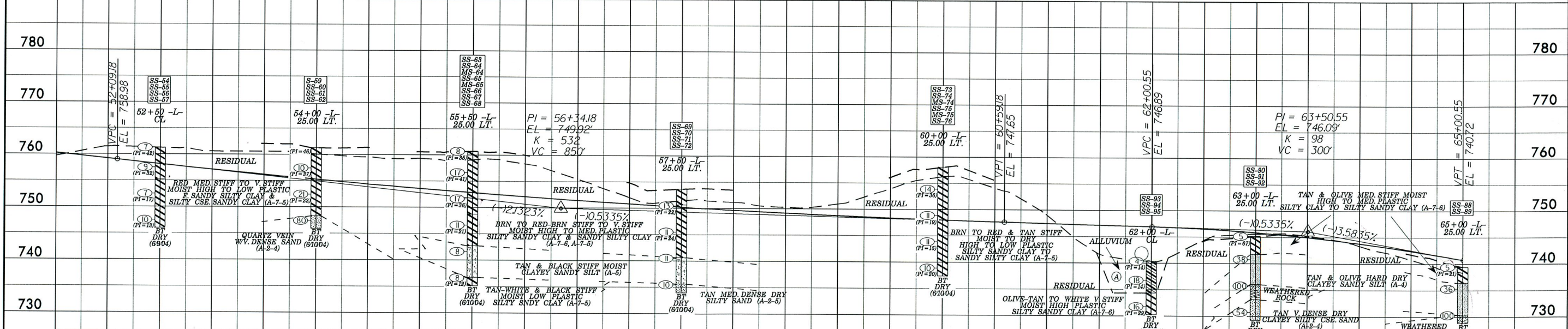

SOIL TEST RESULTS

SAMPLE NO.	OFFSET	STATION	DEPTH INTERVAL	AASHTO CLASS.	LL	PL I.	% BY WEIGHT				% PASSING SIEVES			% MOISTURE	% ORGANIC
							C. SAND	F. SAND	SILT	CLAY	10	40	200		
SS-54	CL	52+50	0.00-1.50	A-7-5(43)	84	42	8.6	8.8	27.2	55.4	100	95	85	-	-
SS-55	CL	52+50	3.80-5.30	A-7-5(37)	74	32	3.3	11.7	35.8	49.2	100	98	91	-	-
SS-56	CL	52+50	8.80-10.30	A-7-5(17)	59	17	8.2	20.3	18.2	53.3	100	95	79	-	-
SS-57	CL	52+50	13.80-15.30	A-7-5(11)	55	13	9.0	33.8	38.7	18.5	100	94	69	-	-
S-59	25 LT	54+00	0.00-3.90	A-7-5(52)	85	46	3.9	6.2	22.3	67.7	100	98	92	-	-
SS-60	25 LT	54+00	3.90-5.40	A-7-5(42)	74	37	1.4	10.9	38.5	49.2	100	99	92	-	-
SS-61	25 LT	54+00	8.90-10.40	A-7-5(6)	54	22	35.1	18.5	23.9	22.6	85	61	43	-	-
SS-62	25 LT	54+00	13.90-15.40	A-2-4(0)	28	NP	41.1	35.2	18.7	5.1	100	73	30	-	-
SS-63	25 LT	55+00	0.00-1.50	A-7-5(24)	60	35	16.8	16.2	16.7	51.3	100	91	70	-	-
SS-64	25 LT	55+00	4.10-5.60	A-7-5(35)	78	41	13.1	14.2	19.4	53.3	100	92	76	26.4	-
SS-65	25 LT	55+00	9.10-10.60	A-7-5(29)	67	36	11.5	19.1	34.8	34.9	100	94	75	40.2	-
SS-66	25 LT	55+00	14.10-15.60	A-7-5(15)	61	21	8.4	35.3	35.8	22.6	100	97	67	-	-
SS-67	25 LT	55+00	19.10-20.60	A-5(2)	52	NP	15.6	33.6	38.5	12.9	100	92	60	-	-
SS-68	25 LT	55+00	24.10-25.60	A-7-5(6)	45	12	15.6	37.9	38.3	8.2	100	92	56	-	-
SS-69	25 LT	57+00	3.20-4.70	A-7-5(19)	63	22	11.5	21.9	29.6	36.9	100	96	73	-	-
SS-70	25 LT	57+00	8.20-9.70	A-7-5(18)	57	24	12.7	21.7	34.8	30.8	100	94	71	-	-
SS-71	25 LT	57+00	13.20-14.70	A-5(6)	52	6	16.6	27.6	40.5	16.4	100	93	64	-	-
SS-72	25 LT	57+00	18.20-19.70	A-2-5(0)	51	NP	27.1	45.7	21.0	6.2	100	89	34	-	-

SOIL TEST RESULTS

SAMPLE NO.	OFFSET	STATION	DEPTH INTERVAL	AASHTO CLASS.	LL	PL I.	% BY WEIGHT				% PASSING SIEVES			% MOISTURE	% ORGANIC
							C. SAND	F. SAND	SILT	CLAY	10	40	200		
SS-73	25 LT	60+00	4.20-5.70	A-7-5(30)	77	36	13.3	17.0	20.4	49.2	99	91	73	-	-
SS-74	25 LT	60+00	9.20-10.70	A-7-5(14)	60	19	15.4	20.3	29.4	34.9	96	86	67	24.3	-
SS-75	25 LT	60+00	14.20-15.70	A-7-5(12)	62	16	12.3	26.1	41.1	20.5	100	93	69	27.0	-
SS-76	25 LT	60+00	19.20-20.70	A-7-5(18)	55	20	10.9	25.4	41.1	22.6	100	94	72	-	-
SS-93	CL	62+00	0.00-1.50	A-6(2)	30	14	31.9	27.9	16.0	24.2	95	75	41	-	-
SS-94	CL	62+00	3.60-9.10	A-6(1)	37	14	40.6	21.0	14.1	24.2	92	65	38	-	-
SS-95	CL	62+00	8.60-10.10	A-7-6(15)	63	29	17.0	29.3	29.5	24.2	96	88	69	-	-
SS-96	25LT	63+00	0.00-1.50	A-7-6(83)	95	67	9.3	8.1	16.0	66.7	100	94	84	-	-
SS-97	25LT	63+00	4.00-5.90	A-7-6(8)	27	8	43.0	27.6	17.2	10.1	100	69	32	-	-
SS-98	25LT	63+00	14.40-15.90	A-2-4(0)	32	NP	45.3	27.6	30.9	28.9	79	71	32	-	-
SS-99	25RT	65+00	4.10-5.60	A-4(0)	23	NP	20.2	46.1	23.6	10.1	96	87	41	-	-

52 53 54 55 56 57 58 59 60 61 62 63 64



SOIL TEST RESULTS

Table with columns: SAMPLE NO., OFFSET, STATION, DEPTH INTERVAL, AASHTO CLASS., L.L., PL. I., % BY WEIGHT (C. SAND, F. SAND, SILT, CLAY), % PASSING SIEVES (10, 40, 200), MOISTURE, ORGANIC.

SOIL TEST RESULTS

Table with columns: SAMPLE NO., OFFSET, STATION, DEPTH INTERVAL, AASHTO CLASS., L.L., PL. I., % BY WEIGHT (C. SAND, F. SAND, SILT, CLAY), % PASSING SIEVES (10, 40, 200), MOISTURE, ORGANIC.

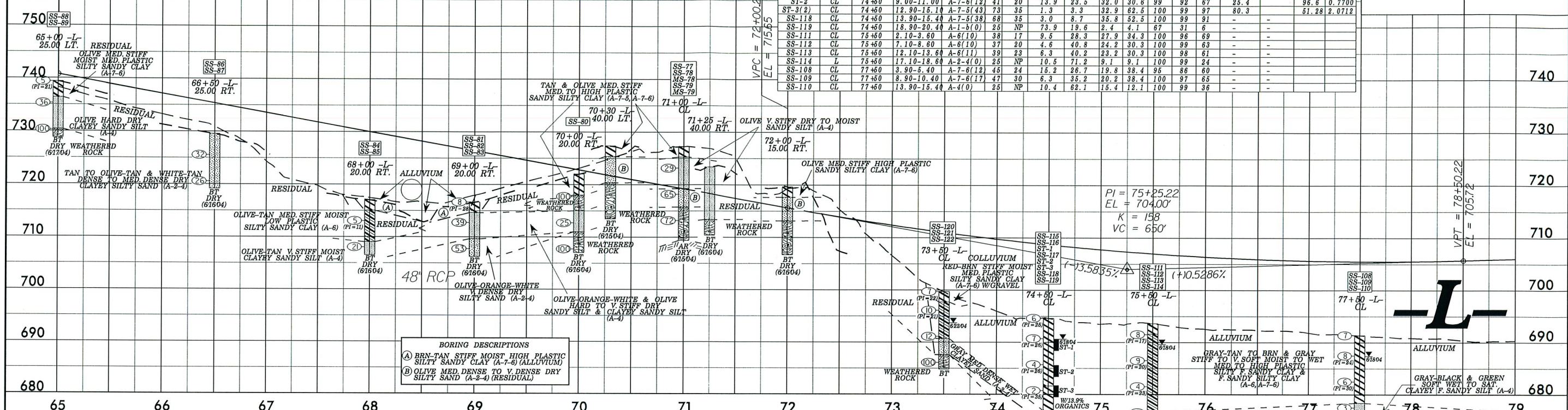

BORING DESCRIPTIONS
(A) BRN-TAN STIFF MOIST HIGH PLASTIC SILTY SANDY CLAY (A-7-6) (ALLUVIUM)
(B) OLIVE MED-DENSE TO V.DENSE DRY SILTY SAND (A-2-4) (RESIDUAL)

SOIL TEST RESULTS

Table with columns: SAMPLE NO., OFFSET, STATION, DEPTH INTERVAL, AASHTO CLASS., L.L., PL. I., % BY WEIGHT (C. SAND, F. SAND, SILT, CLAY), % PASSING SIEVES (10, 40, 200), MOISTURE, ORGANIC.

SOIL TEST RESULTS

Table with columns: SAMPLE NO., OFFSET, STATION, DEPTH INTERVAL, AASHTO CLASS., L.L., PL. I., % BY WEIGHT (C. SAND, F. SAND, SILT, CLAY), % PASSING SIEVES (10, 40, 200), MOISTURE, ORGANIC.

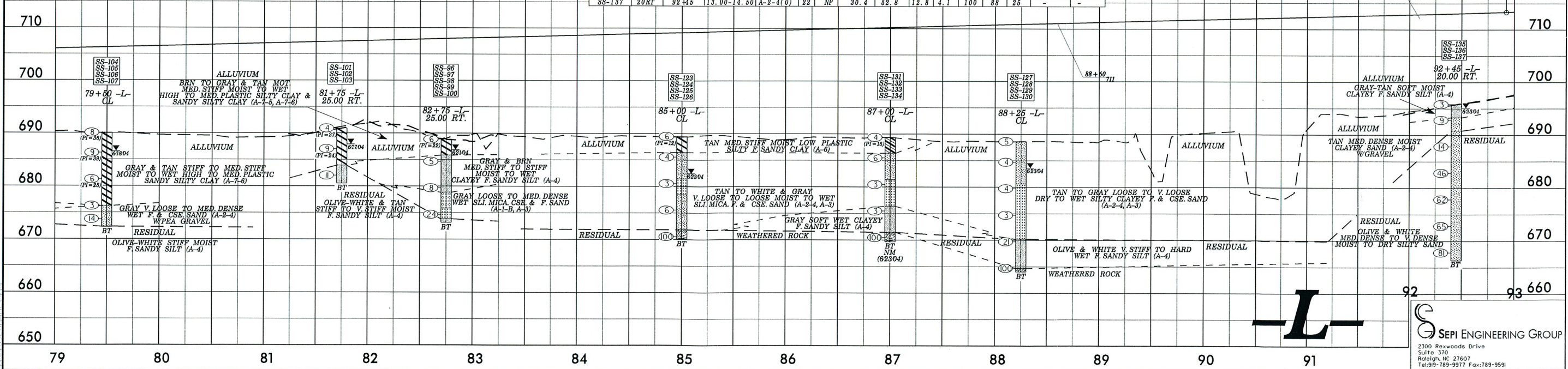

INCOMPLETE PLANS
DO NOT USE FOR A/W ACQUISITION
PRELIMINARY PLANS
DO NOT USE FOR CONSTRUCTION

SOIL TEST RESULTS

SAMPLE NO.	OFFSET	STATION	DEPTH INTERVAL	AASHTO CLASS.	L.L.	P.L.	% BY WEIGHT				% PASSING SIEVES			MOISTURE	% ORGANIC
							C. SAND	F. SAND	SILT	CLAY	10	40	200		
SS-138	CL	94+50	4.20-9.70	A-6(2)	32	12	1.7	61.0	14.8	22.4	98	98	46	-	-
SS-140	CL	96+50	0.00-1.50	A-6(4)	30	14	20.8	34.3	16.3	28.6	100	89	50	-	-
SS-141	CL	96+50	4.20-5.70	A-7-6(30)	68	41	9.8	22.9	8.2	59.2	99	99	71	-	-
SS-142	CL	96+50	9.20-10.70	A-2-4(0)	32	NP	49.1	32.7	9.1	9.2	90	32	19	-	-
SS-143	CL	96+50	14.20-15.70	A-2-4(0)	32	9	62.9	21.2	1.6	14.3	100	52	18	-	-
SS-143B	CL	96+50	19.10-20.60	A-2-6(0)	38	16	64.3	17.3	1.9	16.5	96	49	19	-	-
SS-140.1	CL	98+50	0.00-1.50	A-7-6(18)	56	30	12.8	22.5	4.9	59.8	95	88	65	-	-
SS-141.1	CL	98+50	3.90-5.40	A-7-6(6)	51	24	25.8	27.2	6.8	41.2	86	72	43	-	-
SS-142.1	CL	98+50	8.90-10.40	A-6(5)	38	19	4.3	55.9	8.9	30.9	100	99	47	-	-
SS-143.1	CL	98+50	13.90-15.40	A-7-6(34)	62	37	1.9	19.8	22.7	55.7	100	100	84	-	-
SS-144	CL	98+50	18.90-20.40	A-2-4(0)	28	NP	32.9	54.9	4.9	7.2	100	94	16	-	-
SS-145	CL	98+50	23.90-25.40	A-1-b(0)	27	NP	66.6	25.7	2.6	5.2	83	36	8	-	-
SS-146	CL	98+50	28.90-30.40	A-2-4(0)	34	NP	42.1	35.9	13.8	8.2	92	69	26	-	-
SS-147	CL	100+50	0.00-1.50	A-7-5(40)	74	40	6.2	10.3	23.7	59.8	100	98	85	-	-
SS-148	CL	100+50	4.00-5.50	A-7-5(21)	60	22	7.2	19.8	35.9	37.1	100	97	79	-	-
SS-149	CL	100+50	13.00-14.50	A-7-5(8)	52	15	14.8	36.1	30.5	18.6	100	93	59	-	-
SS-150	CL	102+50	0.00-1.50	A-7-5(27)	63	29	7.4	15.7	27.4	49.5	99	94	81	-	-
SS-151	CL	102+50	4.20-5.70	A-7-5(32)	66	29	2.1	15.1	41.6	41.2	100	99	89	-	-
SS-152	CL	102+50	9.20-10.70	A-7-5(18)	60	16	4.9	18.1	43.9	33.0	100	97	83	-	-
SS-153	10 RT	104+50	4.10-5.60	A-7-5(21)	67	21	6.0	17.9	26.6	49.5	100	97	82	-	-
SS-154	10 RT	104+50	9.10-10.60	A-7-5(38)	76	46	8.7	22.5	31.8	37.1	100	96	77	35.5	-
SS-155	10 RT	104+50	14.10-16.60	A-7-5(11)	64	13	9.1	31.8	42.7	16.5	100	96	70	-	-

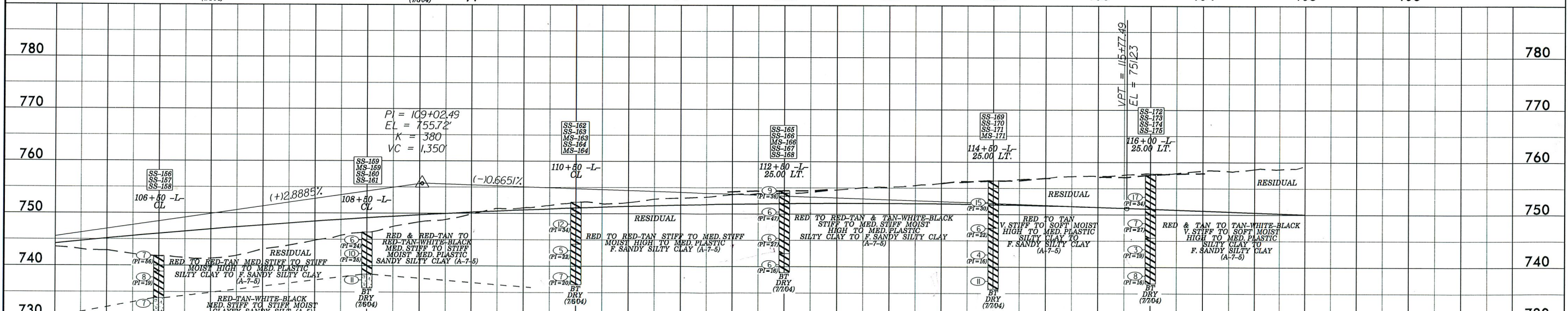
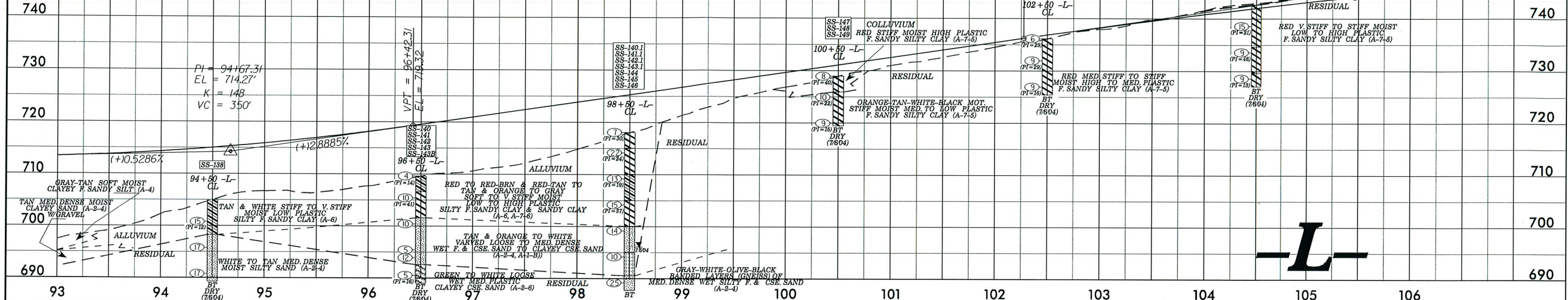

SOIL TEST RESULTS

SAMPLE NO.	OFFSET	STATION	DEPTH INTERVAL	AASHTO CLASS.	L.L.	P.L.	% BY WEIGHT				% PASSING SIEVES			MOISTURE	% ORGANIC
							C. SAND	F. SAND	SILT	CLAY	10	40	200		
SS-156	CL	106+50	0.00-1.50	A-7-5(59)	86	56	3.1	8.0	20.8	68.0	100	98	91	-	-
SS-157	CL	106+50	4.10-5.60	A-7-5(22)	57	19	3.7	14.2	36.7	45.4	100	98	88	-	-
SS-158	CL	106+50	9.10-10.60	A-5(1)	49	NP	22.1	28.5	30.9	18.6	100	84	58	-	-
SS-159	CL	108+50	1.50-3.00	A-7-5(22)	59	24	8.2	18.1	30.3	43.3	100	95	79	42.6	-
SS-160	CL	108+50	4.10-5.60	A-7-5(13)	61	25	23.9	24.3	27.0	24.7	100	84	58	-	-
SS-161	CL	108+50	9.10-10.60	A-5(0)	51	NP	36.3	27.6	25.8	10.3	97	70	41	-	-
SS-162	CL	110+50	4.20-5.70	A-7-5(30)	68	34	7.6	20.5	26.9	45.0	100	96	78	-	-
SS-163	CL	110+50	9.20-10.70	A-7-5(21)	59	22	6.6	18.6	31.8	43.0	100	97	81	39.1	-
SS-164	CL	110+50	14.20-15.70	A-7-5(15)	56	20	6.4	34.6	34.2	24.7	100	98	69	37.9	-
SS-165	25LT	112+50	0.00-1.50	A-7-5(41)	78	36	3.7	7.2	19.5	69.6	100	98	97	-	-
SS-166	25LT	112+50	4.10-5.60	A-7-5(47)	79	47	3.5	13.4	23.9	59.8	100	99	87	32.7	-
SS-167	25LT	112+50	9.10-10.60	A-7-5(33)	69	27	1.2	11.8	33.4	59.6	100	100	92	-	-
SS-168	25LT	112+50	14.10-15.60	A-7-5(19)	57	16	1.9	15.7	37.1	45.4	100	99	88	-	-
SS-169	25LT	114+50	4.10-5.60	A-7-5(38)	69	30	0.4	5.8	32.0	61.9	100	100	97	-	-
SS-170	25LT	114+50	9.10-10.60	A-7-5(25)	62	22	2.5	14.3	34.1	49.1	100	99	88	-	-
SS-171	25LT	114+50	14.10-15.60	A-7-5(18)	55	16	2.5	20.7	42.1	34.8	100	99	85	55.4	-
SS-172	25LT	116+50	4.20-5.70	A-7-5(43)	77	34	0.4	6.1	23.8	69.6	100	100	96	-	-
SS-173	25LT	116+50	9.20-10.70	A-7-5(32)	66	27	0.8	11.7	32.2	55.3	100	100	92	-	-
SS-174	25LT	116+50	14.20-15.70	A-7-5(22)	61	19	3.1	16.2	37.8	43.0	100	99	86	-	-
SS-175	25LT	116+50	19.20-20.70	A-7-5(15)	59	16	7.6	23.7	33.9	34.8	100	98	75	-	-

-L-

-L-

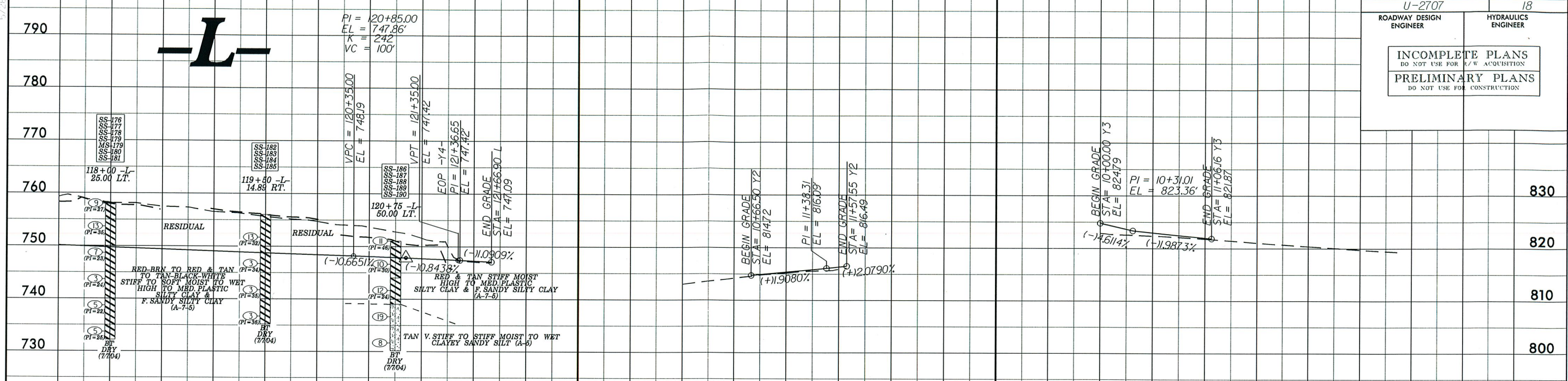

SOIL TEST RESULTS

SAMPLE NO.	OFFSET	STATION	DEPTH INTERVAL	AASHTO CLASS.	LL	PL. I.	% BY WEIGHT				% PASSING SIEVES			% MOISTURE	% ORGANIC
							C. SAND	F. SAND	SILT	CLAY	10	40	200		
SS-176	26LT	118+00	0.00-1.50	A-7-6(25)	56	27	8.6	8.8	13.0	93.6	98	93	82	-	-
SS-177	26LT	118+00	4.30-9.80	A-7-6(47)	82	35	0.4	1.8	22.0	75.7	100	100	82	-	-
SS-178	26LT	118+00	9.30-10.80	A-7-6(31)	68	23	1.4	5.5	29.6	63.5	100	99	95	-	-
SS-179	26LT	118+00	14.30-15.80	A-7-6(31)	64	24	0.8	5.1	24.5	69.6	100	100	96	53.4	-
SS-180	26LT	118+00	19.30-20.80	A-7-6(29)	69	22	2.9	7.6	40.4	49.1	100	99	92	-	-
SS-181	26LT	118+00	24.30-25.80	A-7-6(28)	69	25	2.9	18.4	48.0	30.7	100	99	85	-	-
SS-182	15 RT	119+60	4.30-5.80	A-7-6(42)	76	32	0.4	3.7	32.4	63.5	100	100	97	-	-
SS-183	15 RT	119+60	9.30-10.80	A-7-6(43)	76	34	0.4	4.7	39.6	65.3	100	100	97	-	-
SS-184	15 RT	119+60	14.30-15.80	A-7-6(43)	75	35	1.8	4.3	38.6	65.3	100	99	95	-	-
SS-185	15 RT	119+60	19.30-20.80	A-7-6(43)	76	36	0.8	8.0	48.2	43.0	100	100	94	-	-
SS-186	50LT	120+75	0.00-1.50	A-7-6(48)	82	46	6.3	6.1	15.9	71.6	99	95	88	-	-
SS-187	50LT	120+75	4.40-5.90	A-7-6(36)	76	30	2.3	10.2	28.1	59.4	100	99	91	-	-
SS-188	50LT	120+75	9.40-10.90	A-7-6(18)	65	24	11.1	28.2	27.9	32.8	100	95	68	-	-
SS-189	50LT	120+75	14.40-15.90	A-6(6)	51	9	20.5	26.4	26.5	26.6	100	87	59	-	-
SS-190	50LT	120+75	19.40-20.90	A-6(0)	47	NP	33.2	29.7	24.9	12.3	100	79	44	-	-

SOIL TEST RESULTS

SAMPLE NO.	OFFSET	STATION	DEPTH INTERVAL	AASHTO CLASS.	LL	PL. I.	% BY WEIGHT				% PASSING SIEVES			% MOISTURE	% ORGANIC
							C. SAND	F. SAND	SILT	CLAY	10	40	200		
SS-23	25 LT	12+25	4.10-5.60	A-7-6(31)	72	34	12.6	10.2	18.1	59.1	99	92	78	-	-
SS-24	25 LT	12+25	9.10-10.60	A-7-6(24)	61	20	4.1	8.4	28.5	59.1	100	98	90	-	-
SS-21	49.89LT	13+50.63	4.20-5.70	A-7-6(24)	63	24	7.3	14.1	35.8	42.8	100	96	82	-	-
SS-22	49.89LT	13+50.63	8.20-9.70	A-7-6(22)	59	22	5.9	16.9	36.5	40.7	100	98	82	-	-
SS-18	2.55RT	15+49.80	0.00-4.00	A-7-6(34)	69	38	10.2	10.6	16.1	63.1	99	93	80	-	-
SS-19	2.55RT	15+49.80	4.00-5.50	A-7-6(29)	72	35	13.4	12.8	16.7	57.0	99	91	75	-	-
SS-20	2.55RT	15+49.80	9.00-10.50	A-7-6(25)	63	32	13.4	14.9	31.0	40.7	98	90	74	-	-
SS-1	8.93RT	18+34.93	0.00-1.50	A-7-6(28)	64	31	9.8	12.2	25.1	53.0	100	95	80	-	-
SS-2	8.93RT	18+34.93	3.80-5.30	A-7-6(11)	42	20	19.8	19.6	22.0	38.7	99	86	64	-	-
SS-3	8.93RT	18+34.93	8.80-10.30	A-7-6(49)	85	50	7.1	9.6	16.1	67.2	100	96	85	-	-
SS-4	8.93RT	18+34.93	13.80-15.30	A-6(7)	48	7	7.7	31.2	36.7	24.4	100	97	71	-	-
SS-5	8.93RT	18+34.93	18.80-20.30	A-6(8)	51	9	12.0	29.7	39.9	18.3	100	95	68	-	-
SS-6	8.93RT	18+34.93	23.80-25.30	A-7-6(8)	50	13	14.9	32.2	34.6	18.3	100	94	62	-	-
SS-7	8.93RT	18+34.93	28.30-30.30	A-7-6(9)	54	14	13.8	33.4	38.5	14.3	100	95	62	-	-
SS-8	8.93RT	18+34.93	33.80-40.30	A-6(2)	49	NP	17.9	29.1	38.7	14.3	100	91	63	-	-
SS-9	8.93RT	18+34.93	43.80-45.30	A-7-6(19)	56	22	3.9	32.4	49.5	14.3	100	99	76	-	-
SS-10	8.93RT	18+34.93	48.80-50.30	A-7-6(6)	44	12	13.6	36.7	35.4	14.3	100	95	59	-	-
SS-11	8.93RT	18+34.93	53.80-55.30	A-4(0)	34	7	24.8	41.1	25.9	8.1	100	90	42	-	-
SS-12	8.93RT	18+34.93	58.30-60.30	A-2-4(0)	30	4	35.4	38.7	21.8	4.1	100	81	35	-	-
SS-13	8.93RT	18+34.93	63.80-65.30	A-2-4(0)	29	NP	27.5	49.9	20.6	2.0	100	89	30	-	-
SS-14	8.93RT	18+34.93	68.80-70.30	A-2-4(0)	27	NP	39.7	36.5	19.8	4.1	98	78	29	-	-

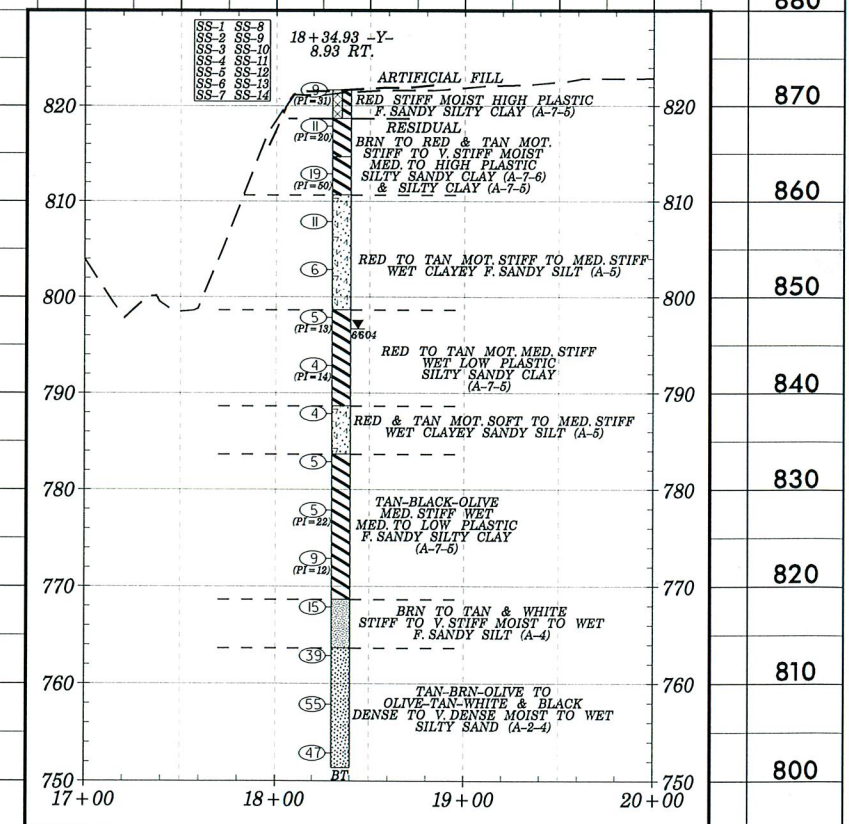
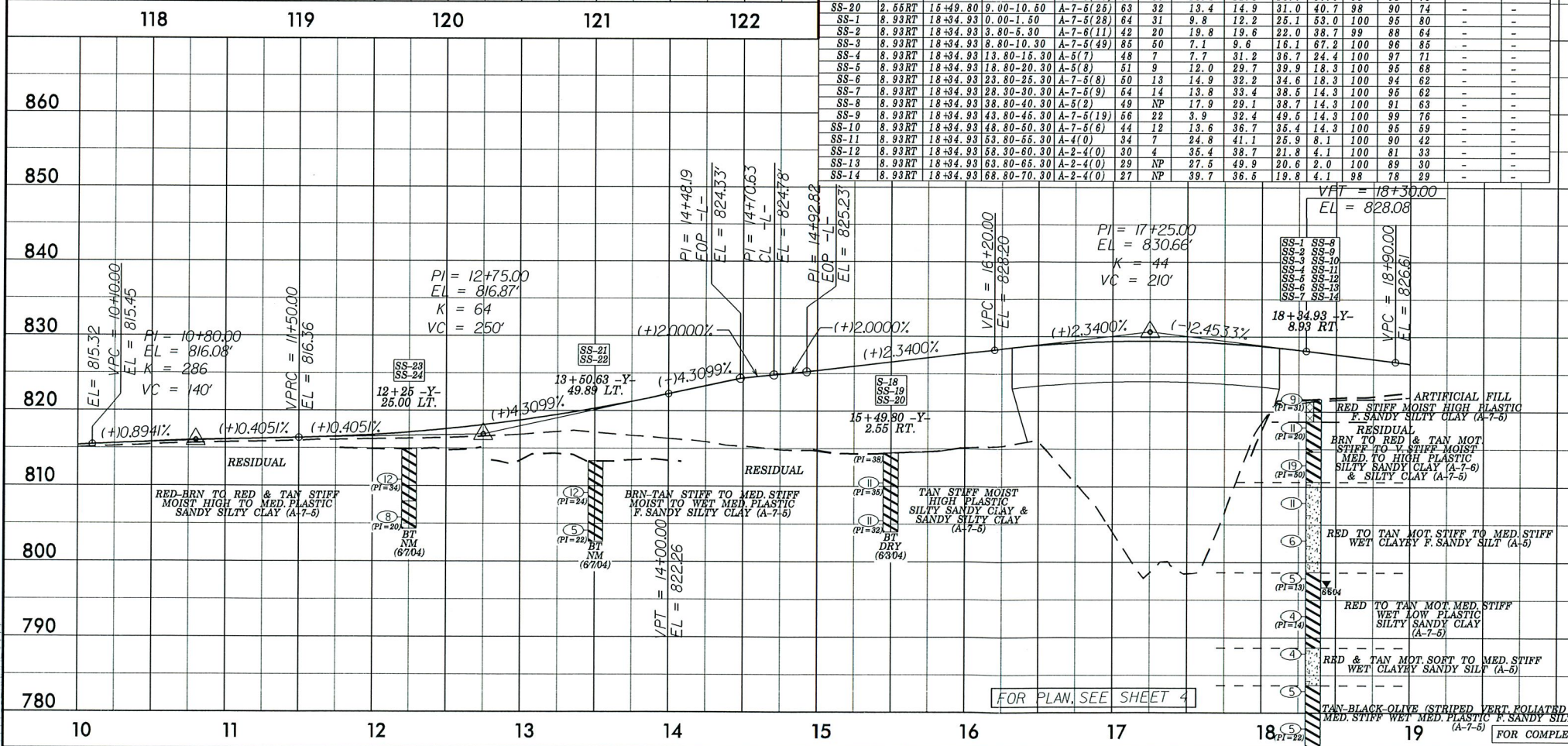

FOR PLAN, SEE SHEET 4

FOR COMPLETE BORING SEE INSET

INCOMPLETE PLANS
DO NOT USE FOR A/W ACQUISITION
PRELIMINARY PLANS
DO NOT USE FOR CONSTRUCTION

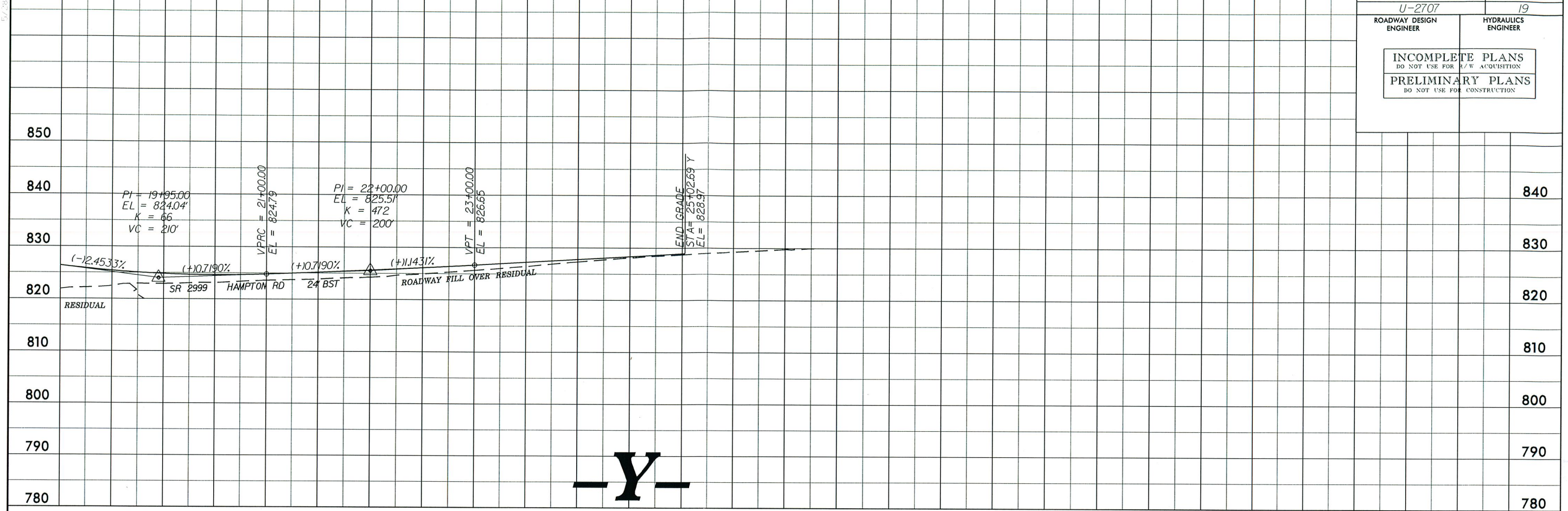

-Y4-

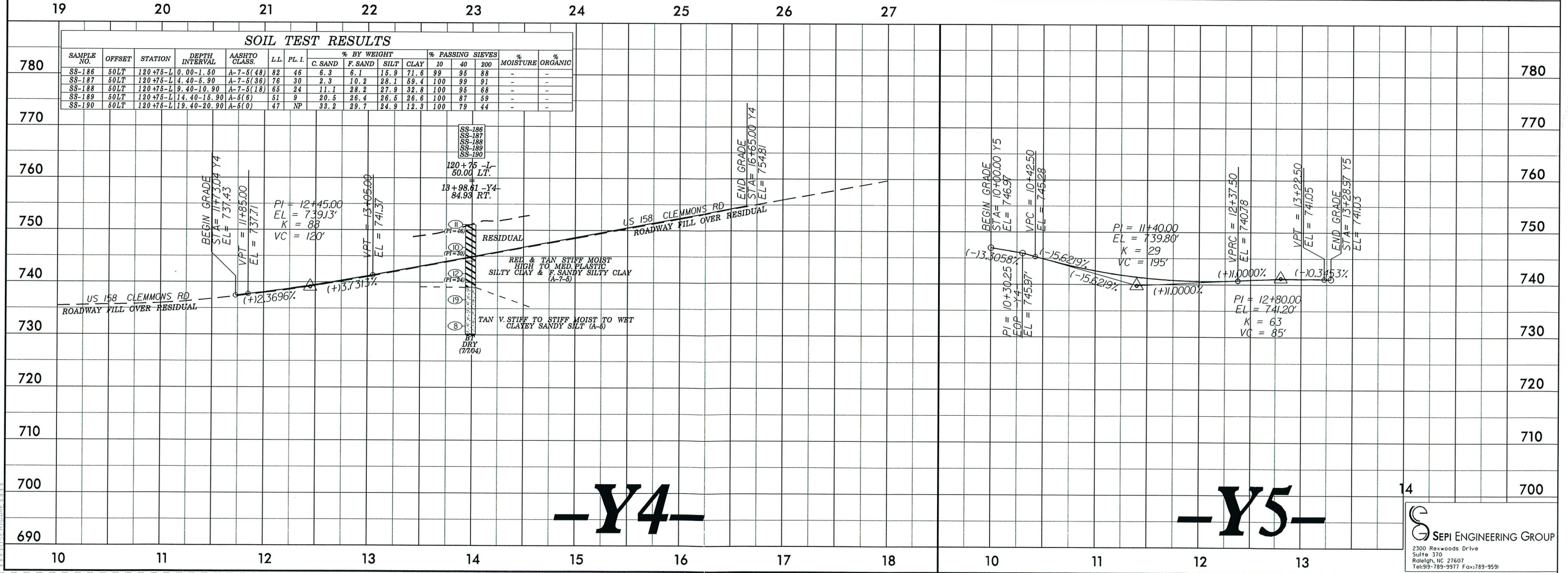

-Y4-

-Y5-

SOIL TEST RESULTS

SAMPLE NO.	OFFSET	STATION	DEPTH INTERVAL	AASHTO CLASS.	LL	PL. I.	% BY WEIGHT				% PASSING SIEVES			% MOISTURE	% ORGANIC
							C. SAND	F. SAND	SILT	CLAY	10	40	200		
SS-186	50LT	120+75-L	0.00-1.50	A-7-5(48)	82	46	6.3	6.1	15.9	71.6	99	95	88	-	-
SS-187	50LT	120+75-L	4.40-5.90	A-7-5(38)	76	30	2.3	10.2	28.1	69.4	100	99	91	-	-
SS-188	50LT	120+75-L	9.40-10.90	A-7-5(18)	65	24	11.1	28.2	27.9	32.8	100	95	68	-	-
SS-189	50LT	120+75-L	14.40-15.90	A-5(6)	51	9	20.8	26.4	26.6	26.6	100	87	59	-	-
SS-190	50LT	120+75-L	19.40-20.90	A-5(0)	47	NP	33.2	29.7	24.9	12.3	100	79	44	-	-

RESIDUAL
REL & TAN STIFF MOIST
HIGH TO MED PLASTIC
SILTY CLAY & F SANDY SILTY CLAY
(A-7-5)
TAN V. STIFF TO STIFF MOIST TO WET
CLAYEY SANDY SILT (A-6)
BY
DR
(2704)