

Cable Entrances at Top of Pole

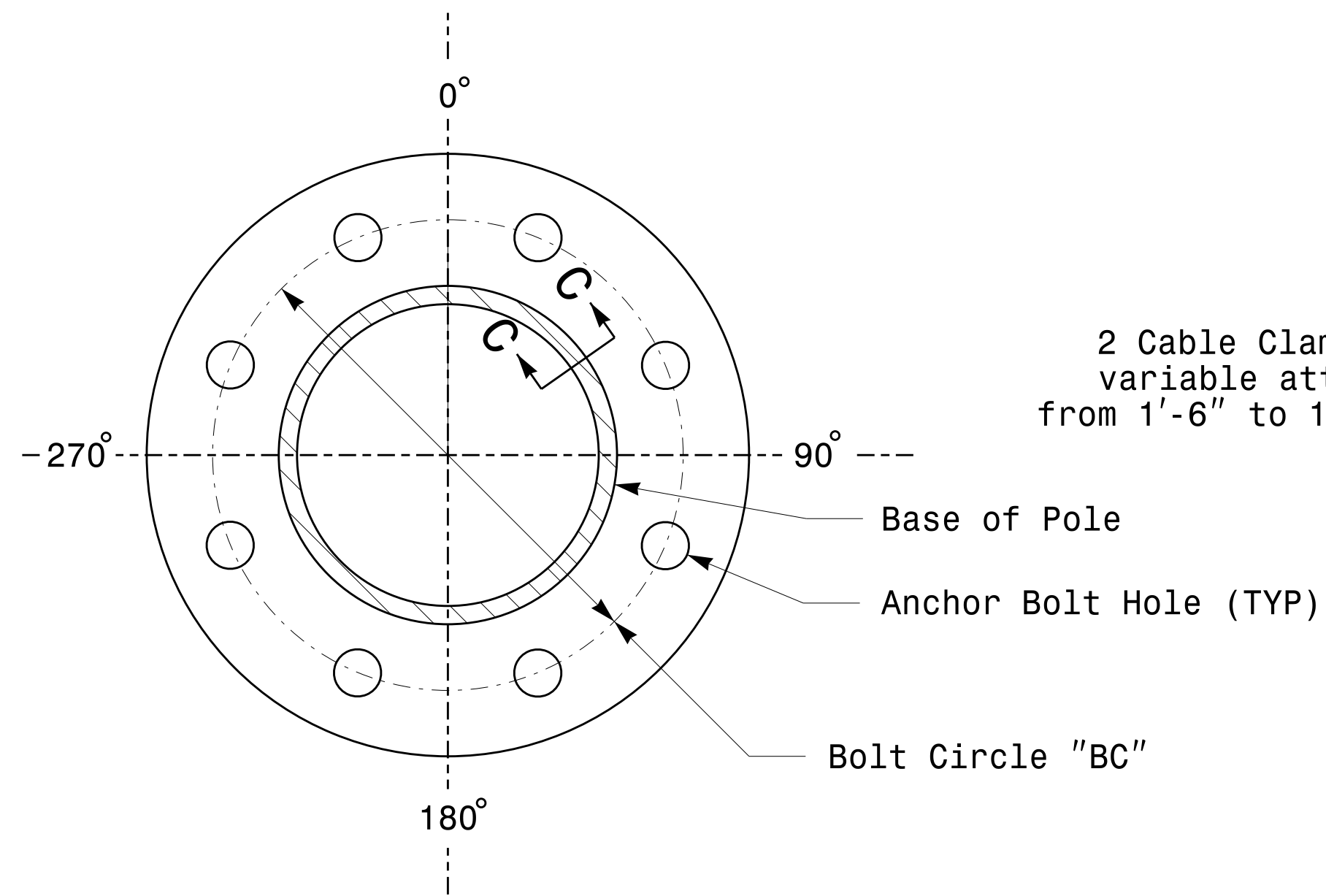

Section B-B
Pole Base Plate
(See drawing M2)

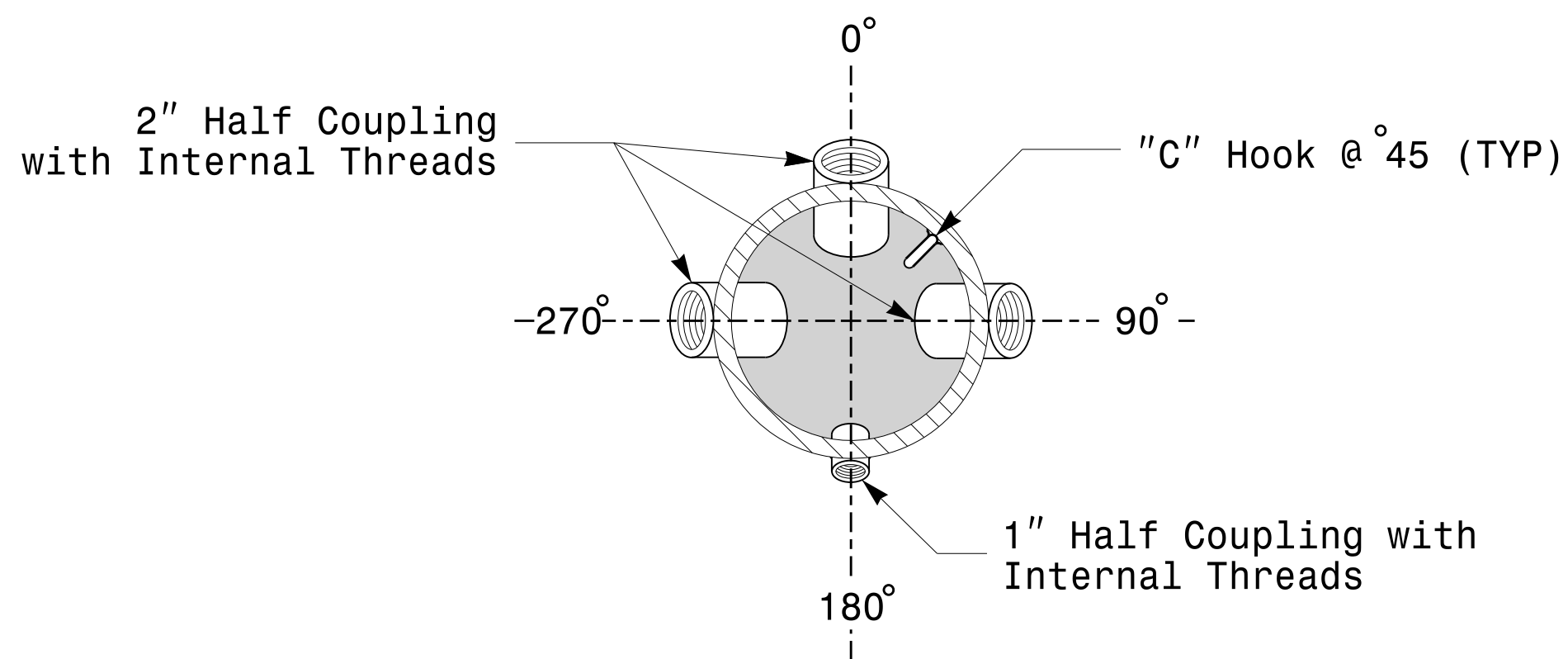

Radial Orientation for Factory Installed
Accessories at Top of Pole

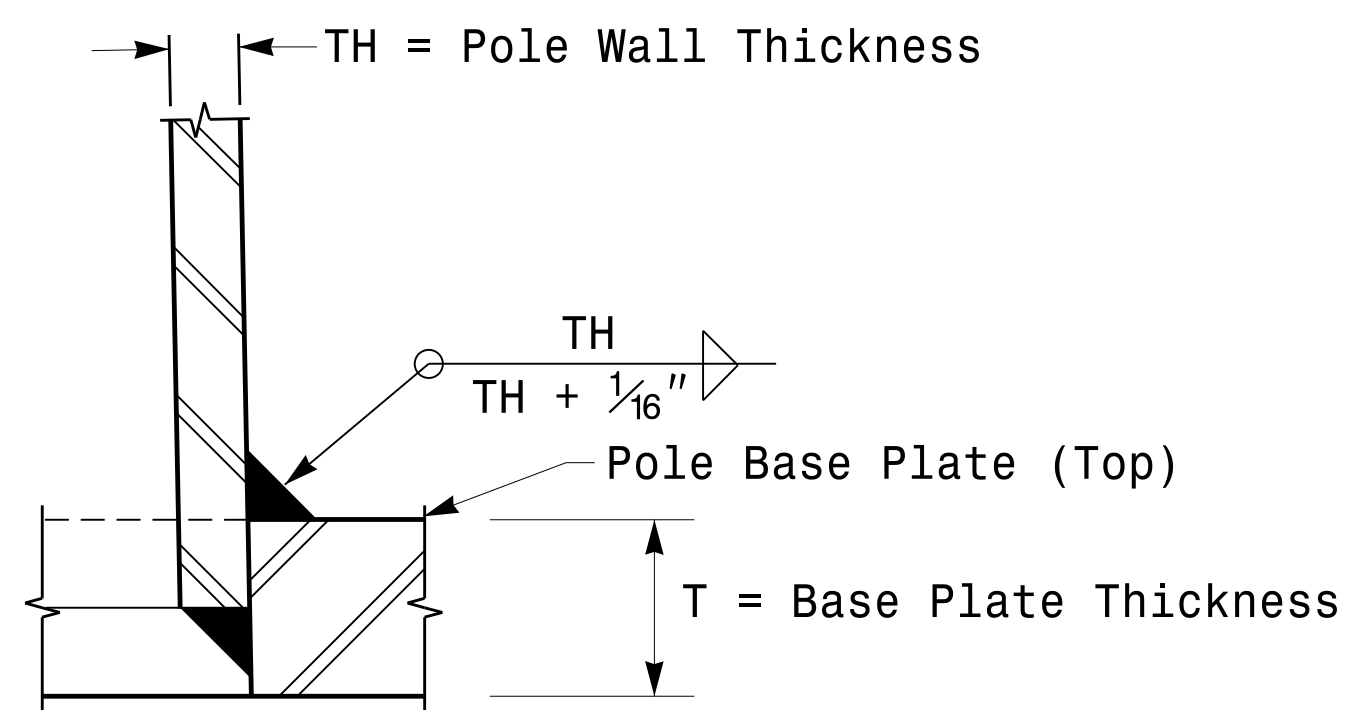

Socket Connection Weld Detail

2 Cable Clamps designed for variable attachment heights from 1'-6" to 10' below the top of the pole.

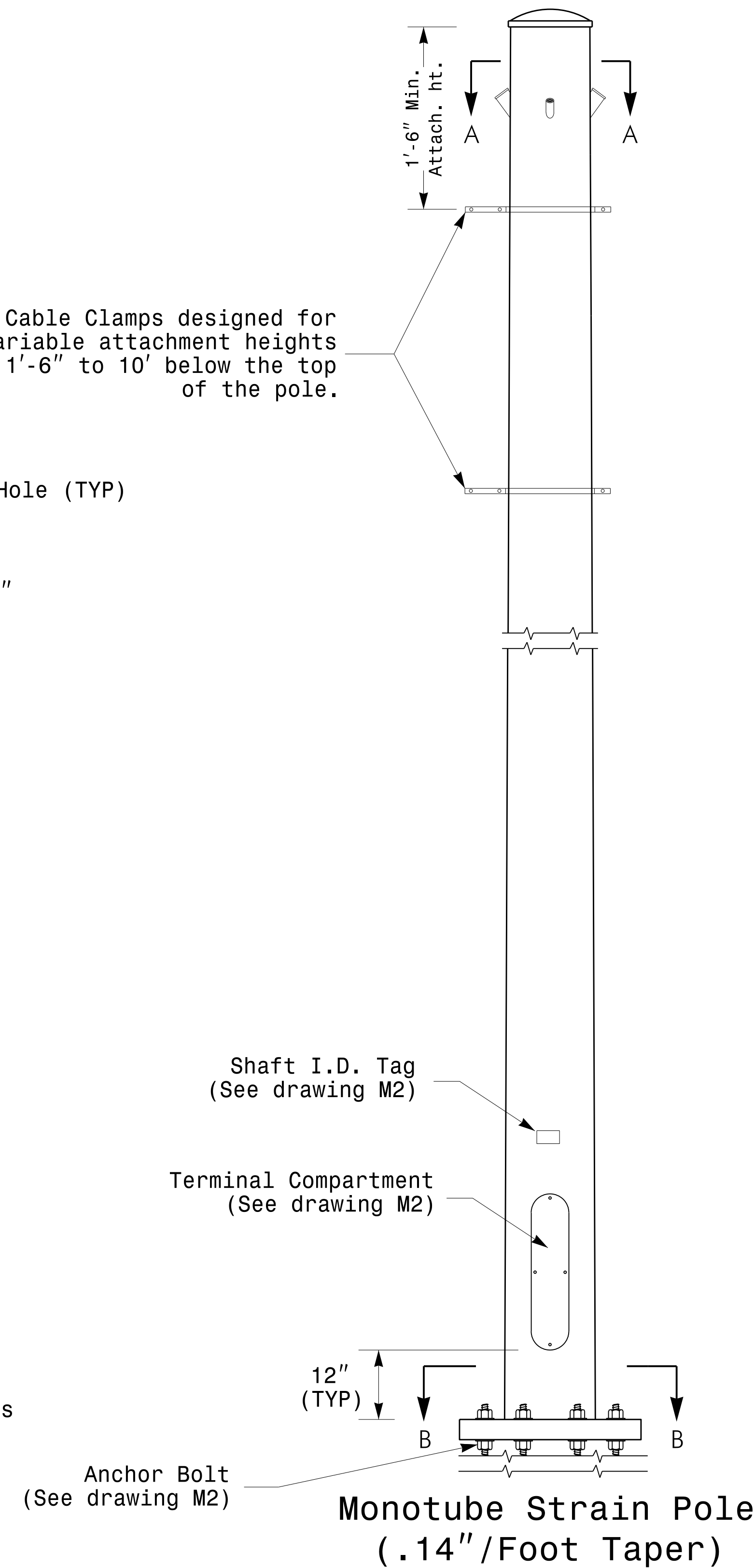

Monotube Strain Pole
(.14\"/>

	Typical Fabrication Details For Strain Poles		
	PLAN DATE: AUGUST 2013 PREPARED BY: N. BITTING	DESIGNED BY: C.F. ANDREWS REVIEWED BY: D.C. SARKAR	
SCALE: 0 NA NONE	REVISIONS: _____ INIT.: _____ DATE: _____	SIG. INVENTORY NO. _____	_____

06-AUG-2014 09:51
 S:\TDS\Signal Design Section\Eastern Region\MM Sheets\2012_M3_Fab_Details_Strain_Poles.dgn
 Top of Pole

Fabrication Details – Strain Poles