

**This electronic collection of documents is provided  
for the convenience of the user  
and is Not a Certified Document –**

**The documents contained herein were originally issued  
and sealed by the individuals whose names and license  
numbers appear on each page, on the dates appearing  
with their signature on that page.**

**This file or an individual page  
shall not be considered a certified document.**

### High Speed Detection (≥40 mph)

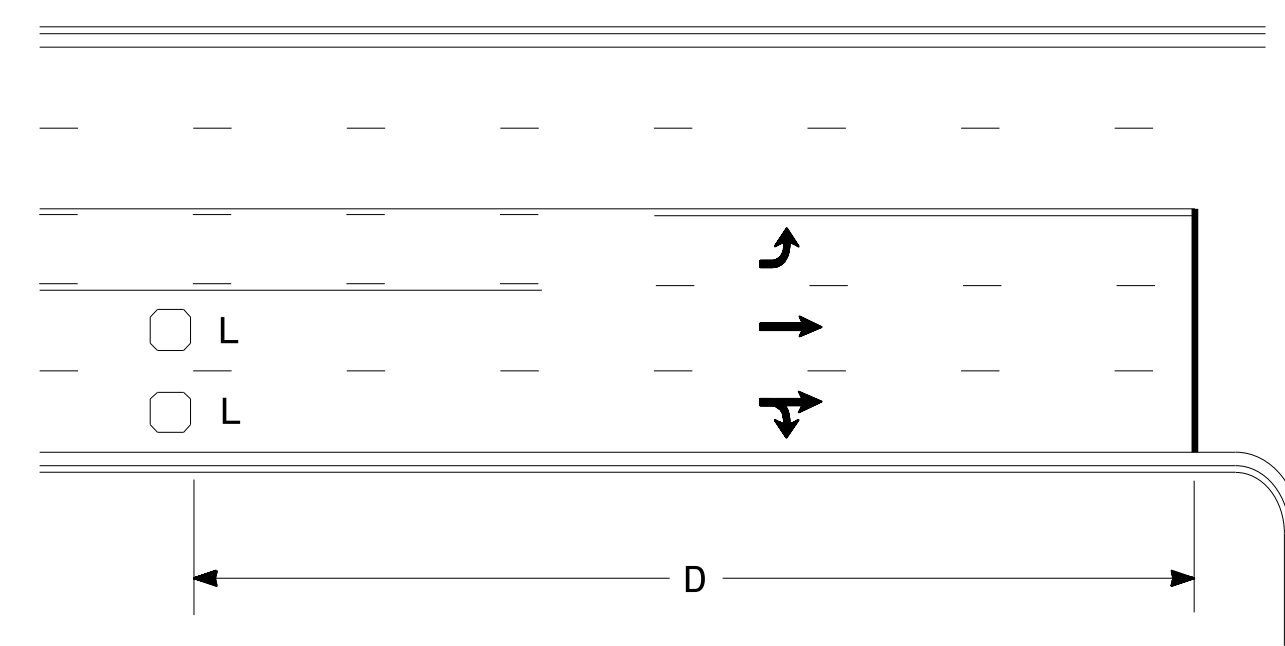

Speed Limit mph	D ft
40	250
45	300
50	355
55	420

L = 6ft X 6ft  
Wired in series for TS1  
Controllers  
Wired separately for TS2,  
170, and 2070L Controllers

Volume Density Operation

OR

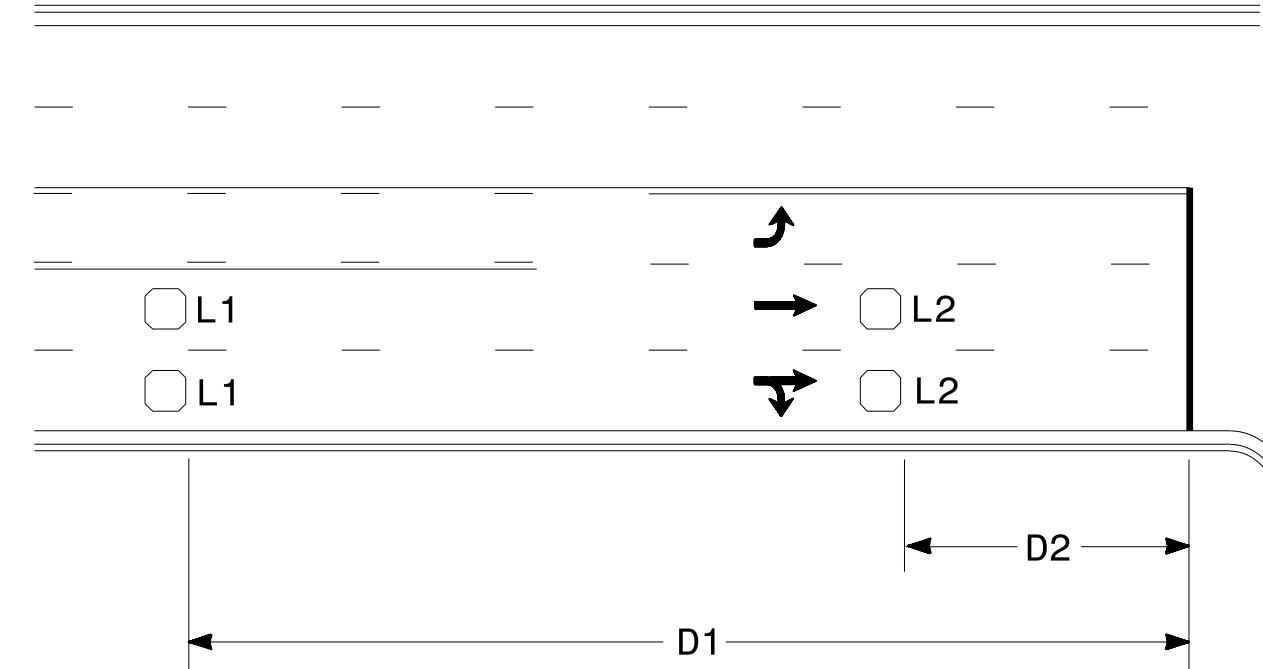

Speed Limit mph	D1 ft	D2 ft
40	250	80
45	300	90
50	355	100
55	420	110

L1 = 6ft X 6ft  
Wired in series  
L2 = 6ft X 6ft  
Wired in series

"Stretch" Operation

### Low Speed Detection (≤35 mph)

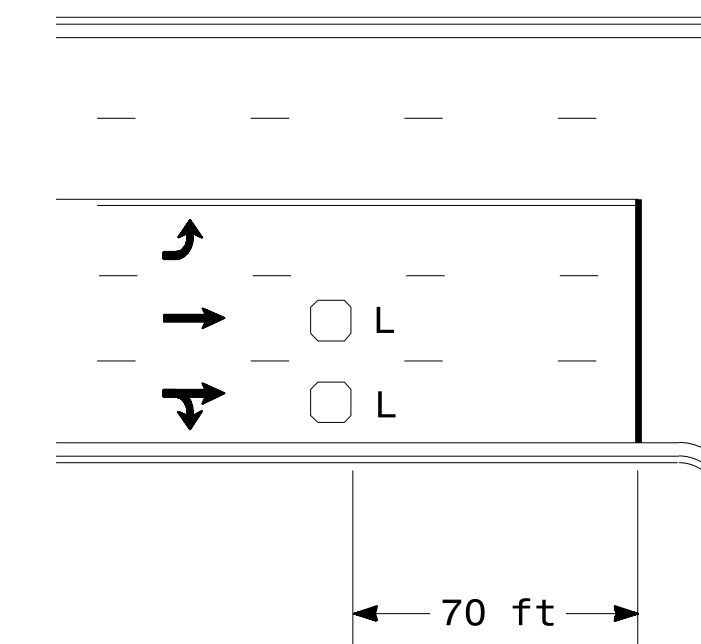

L = 6ft X 6ft  
Wired in series

OR

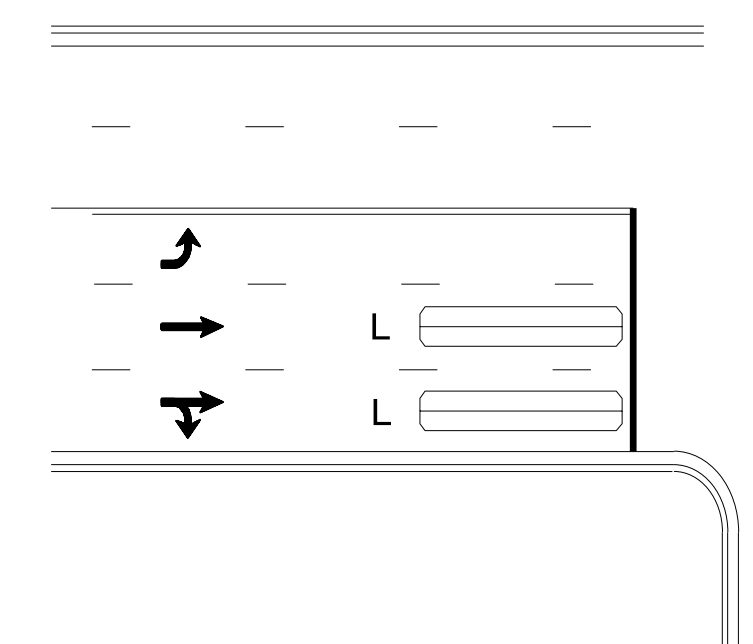

L = 6ft X 40ft  
Quadrupole loop, wired separately

### Left Turn Lane Detection

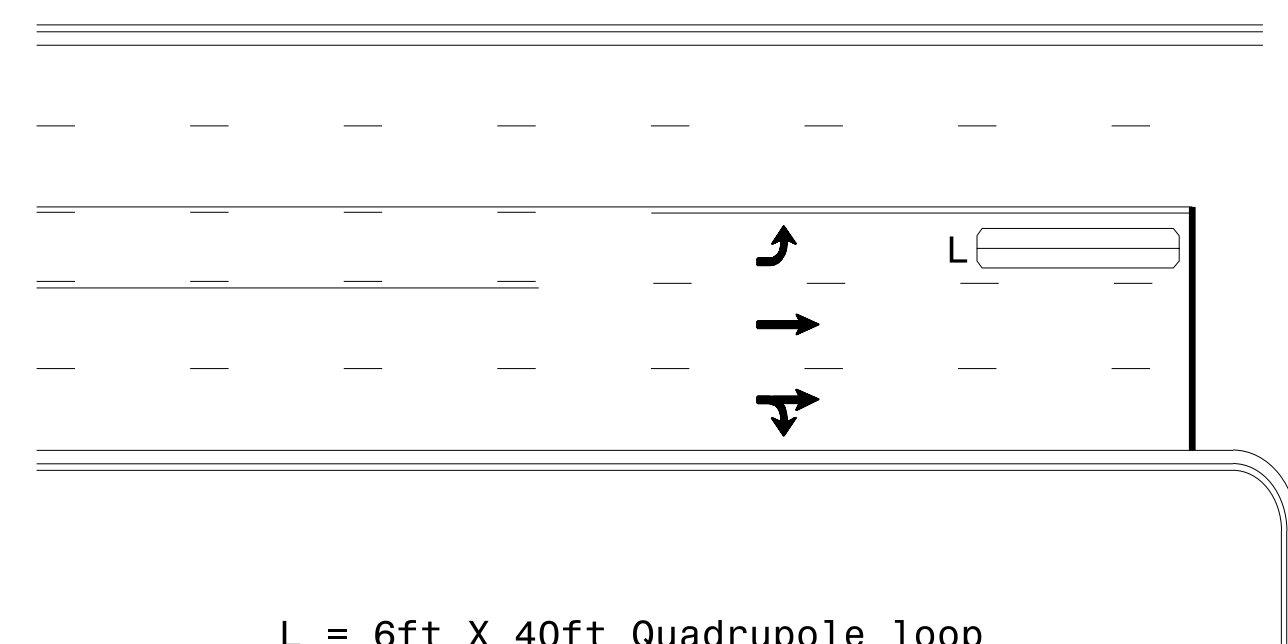

L = 6ft X 40ft Quadrupole loop

Presence Loop Detection

OR

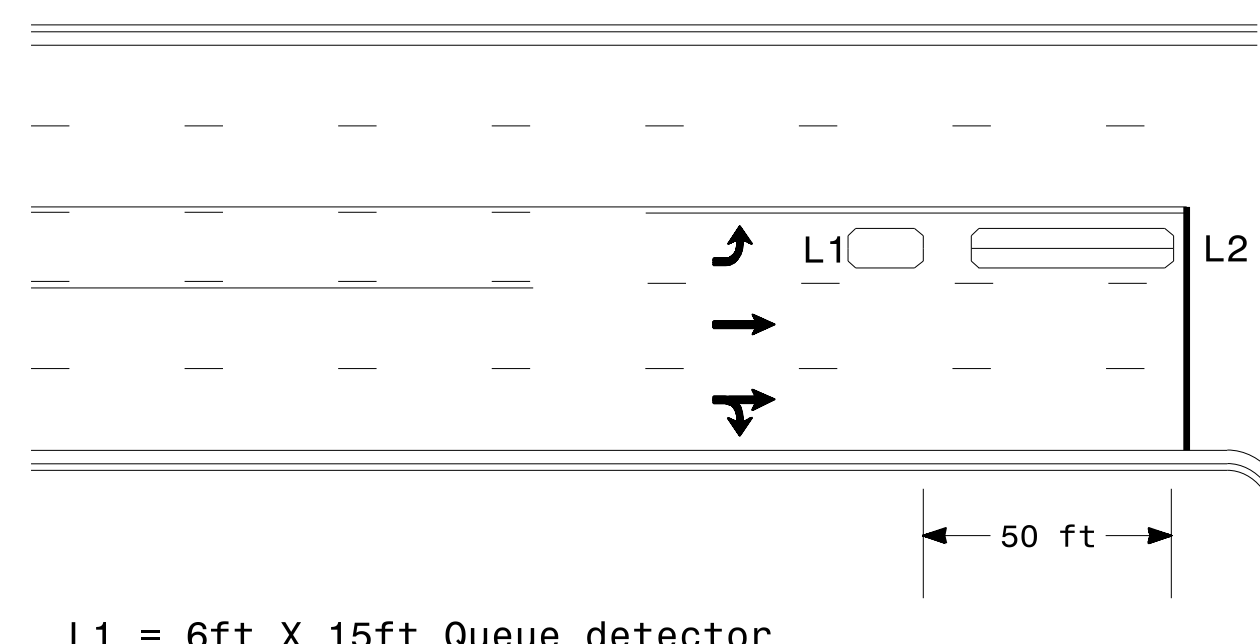

L1 = 6ft X 15ft Queue detector  
L2 = 6ft X 40ft Quadrupole loop

Queue Loop Detection

### Right Turn Lane Detection

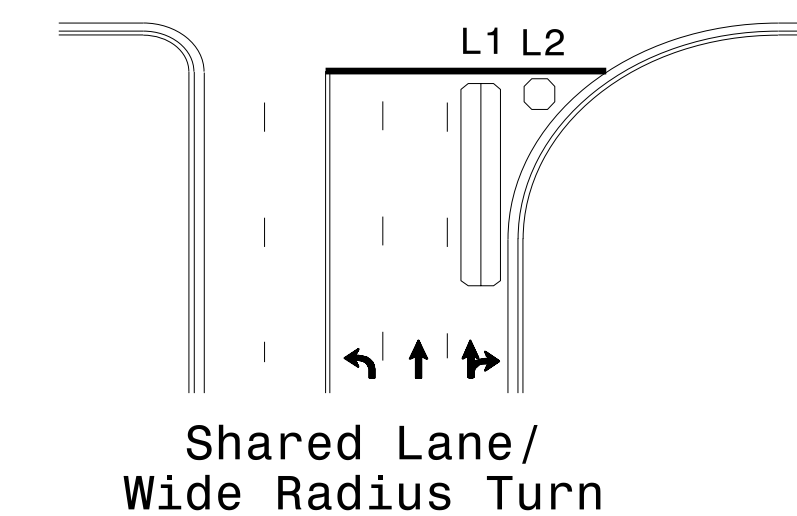

Shared Lane/  
Wide Radius Turn

L1 = 6ft X 40ft Quadrupole loop  
L2 = 6ft X 6ft [Minimum] Presence loop  
Wired separately

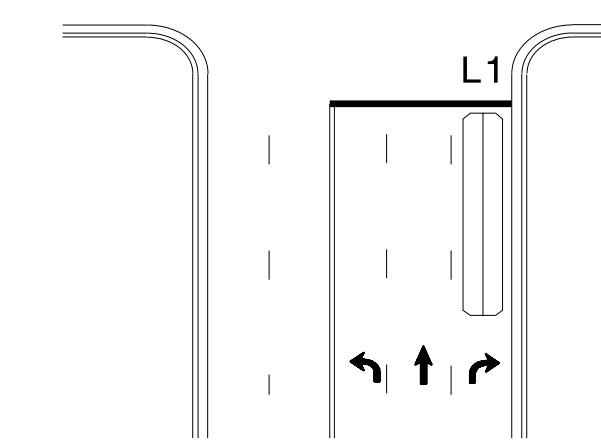

Standard Turn

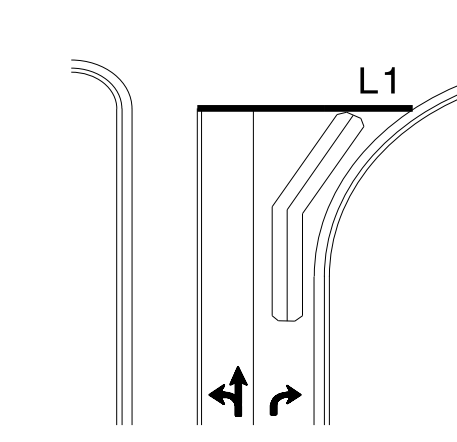

Wide Radius Turn

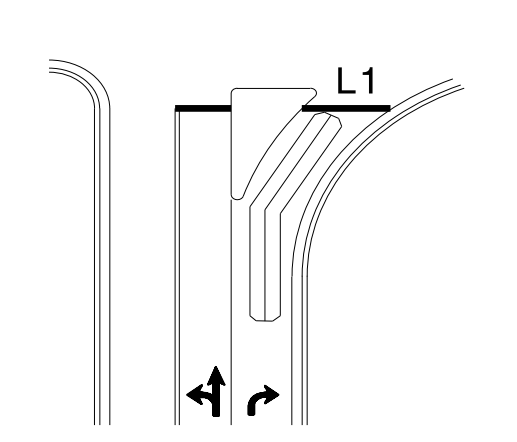

Channelized Turn

### Side Street Detection

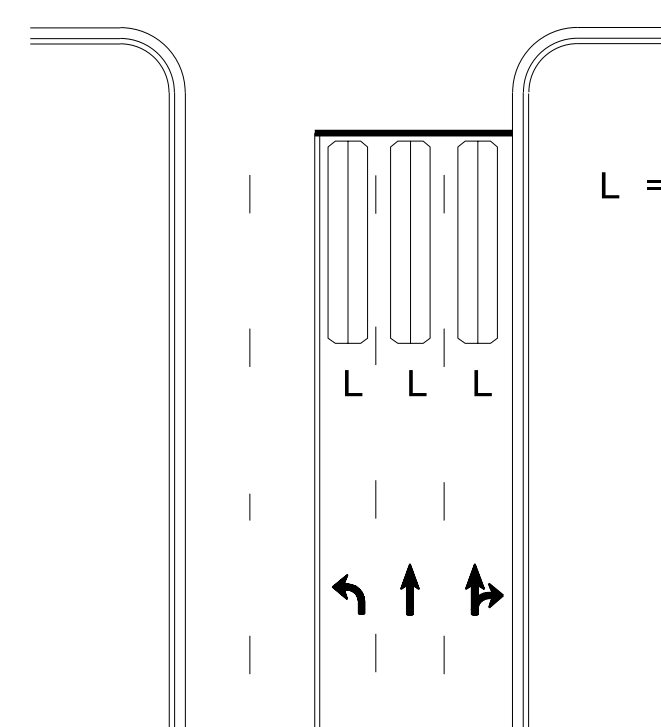

L = 6ft X 40ft  
Quadrupole loop  
Wired to separate  
detectors/channels

### Presence Loop Placement at Stop Lines

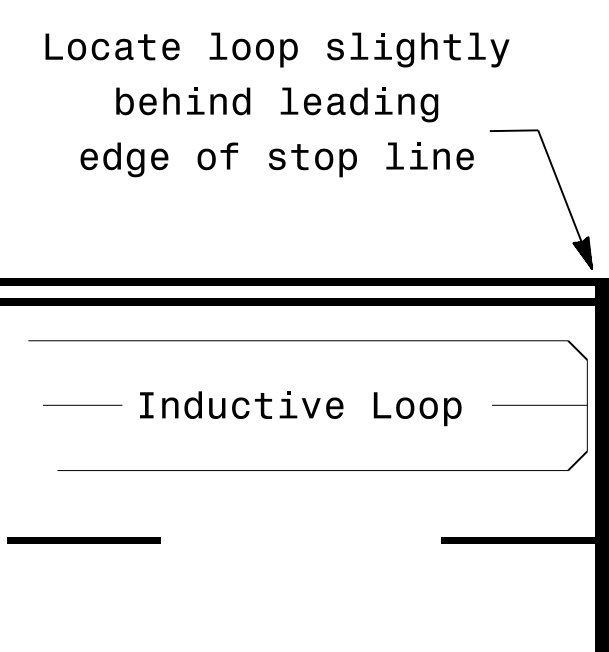

Locate loop slightly  
behind leading  
edge of stop line

Note:  
Loop may be located in advance  
of stop line under any of the  
following conditions:  
1) stop line is greater than 15'  
from edge of intersecting  
roadway  
2) loop detects a permissive or  
protected/permissive left turn  
3) for an exclusive right turn  
lane

### Recommended Number of Turns

Single 6' X 6' loop  
(when wired separately):

Length of Lead-in ft	Number of Turns
< 250	3
250-375	4
375-525	5
> 525	6

Quadrupole loops: Use 2-4-2 turns

6' X 15' Loops:  
Lead-in < 150', use 2 turns  
Lead-in > 150', use 3 turns

Prepared In the Offices of:  
TRANSPORTATION MOBILITY AND SAFETY DIVISION  
STATE OF NORTH CAROLINA  
SIGNAL DESIGN SECTION  
750 N. Greenfield Pkwy, Garner, NC 27529

#### Typical Signal Loop Locations

PLAN DATE: January 2015	REVIEWED BY: JPG
PREPARED BY: PLA	REVIEWED BY:
REVISIONS	INIT. DATE

SCALE: N/A

SEAL  
NORTH CAROLINA  
PROFESSIONAL ENGINEER  
SEAL  
23489  
PANELA L. ALEXANDER  
1/30/2015

STATE OF NORTH CAROLINA  
DEPT. OF TRANSPORTATION  
DIVISION OF HIGHWAYS  
RALEIGH, N.C.

ENGLISH STANDARD DRAWING FOR  
**DEEP-CUT INDUCTIVE DETECTION LOOPS**  
(FOR INSTALLATION PRIOR TO MILLING)

SHEET 1 OF 1

**NOTES**

- OVERLAP SAW CUTS AT CORNERS AND INTERSECTION POINTS TO ENSURE UNIFORM SAW SLOT DEPTH.
- MAINTAIN 12" SPACING BETWEEN LOOP WIRE TAIL SECTIONS.
- WIRE LOOPS CONNECTED TO THE SAME DETECTOR IN SERIES.
- LOCATE LOOPS IN CENTER OF LANES UNLESS OTHERWISE SHOWN ON PLANS.
- USE A SERIES OF ONE INCH PIECES OF BACKER ROD SPACED ONE FOOT APART ALONG THE ENTIRE LENGTH OF THE FEEDER SLOT AND LOOP SAW SLOT.
- CONSULT LOOP SEALANT MANUFACTURER TO DETERMINE CURING TIME REQUIRED PRIOR TO MILLING.
- REFER TO STANDARD DRAWING 1725.01 SHEETS 2 AND 3 FOR ADDITIONAL REQUIREMENTS.

**SAW SLOT DEPTH CHART**  
ASSUMING 2" MILLING DEPTH

DEPTH (IN)	MAX NO. OF WIRE LAYERS				
	2	3	4	5	6
SAW SLOT DEPTH	4.0	4.5	5.0	5.0	5.0
MINIMUM TOTAL ASPHALT DEPTH REQUIRED	5.0	5.5	6.0	6.0	6.0

**LOOP WIRE TWISTING METHOD**

INCORRECT WAY TO TWIST WIRE



CORRECT WAY TO TWIST WIRE

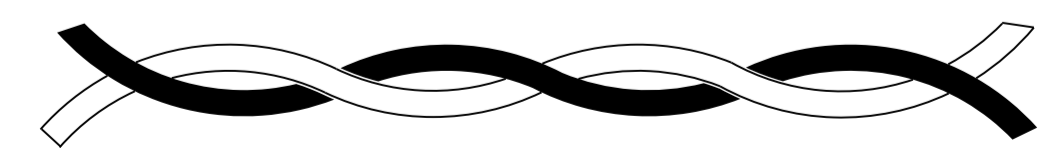

**CONVENTIONAL 4-SIDED LOOP**

**SAW CUT OPTIONS**

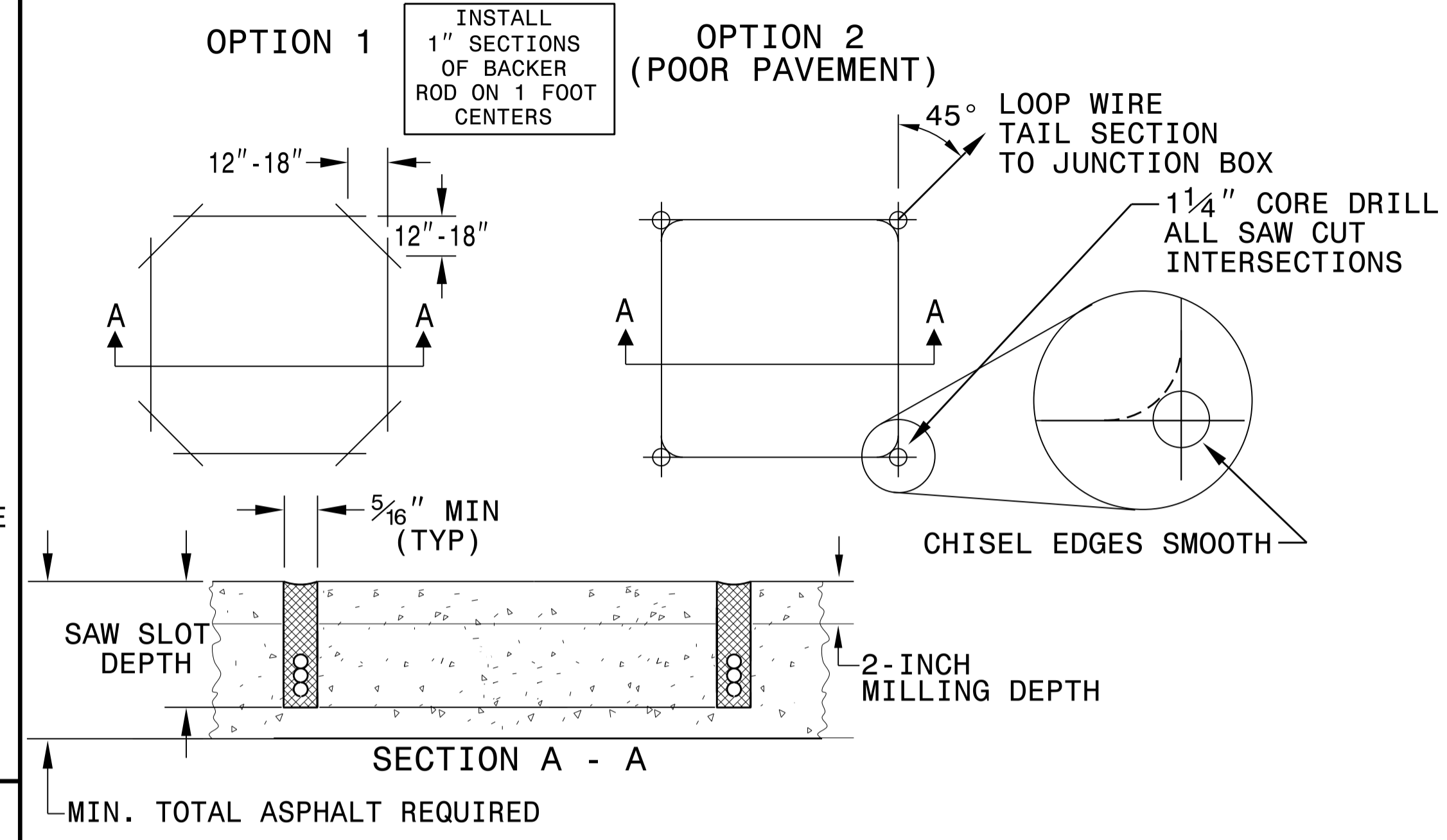

**LOOP WINDING METHOD**

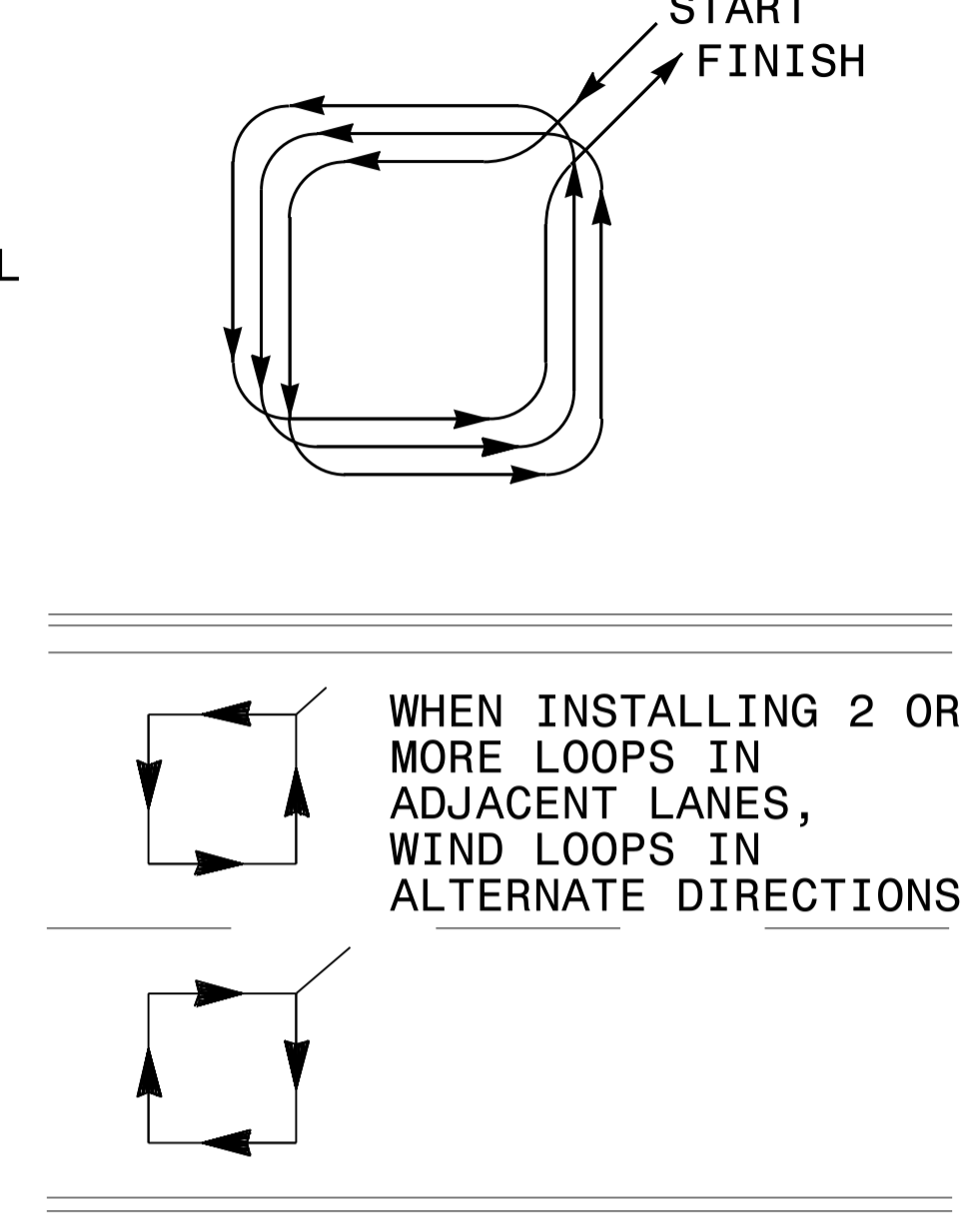

**QUADRUPOLE LOOP**

**SAW CUT OPTIONS**

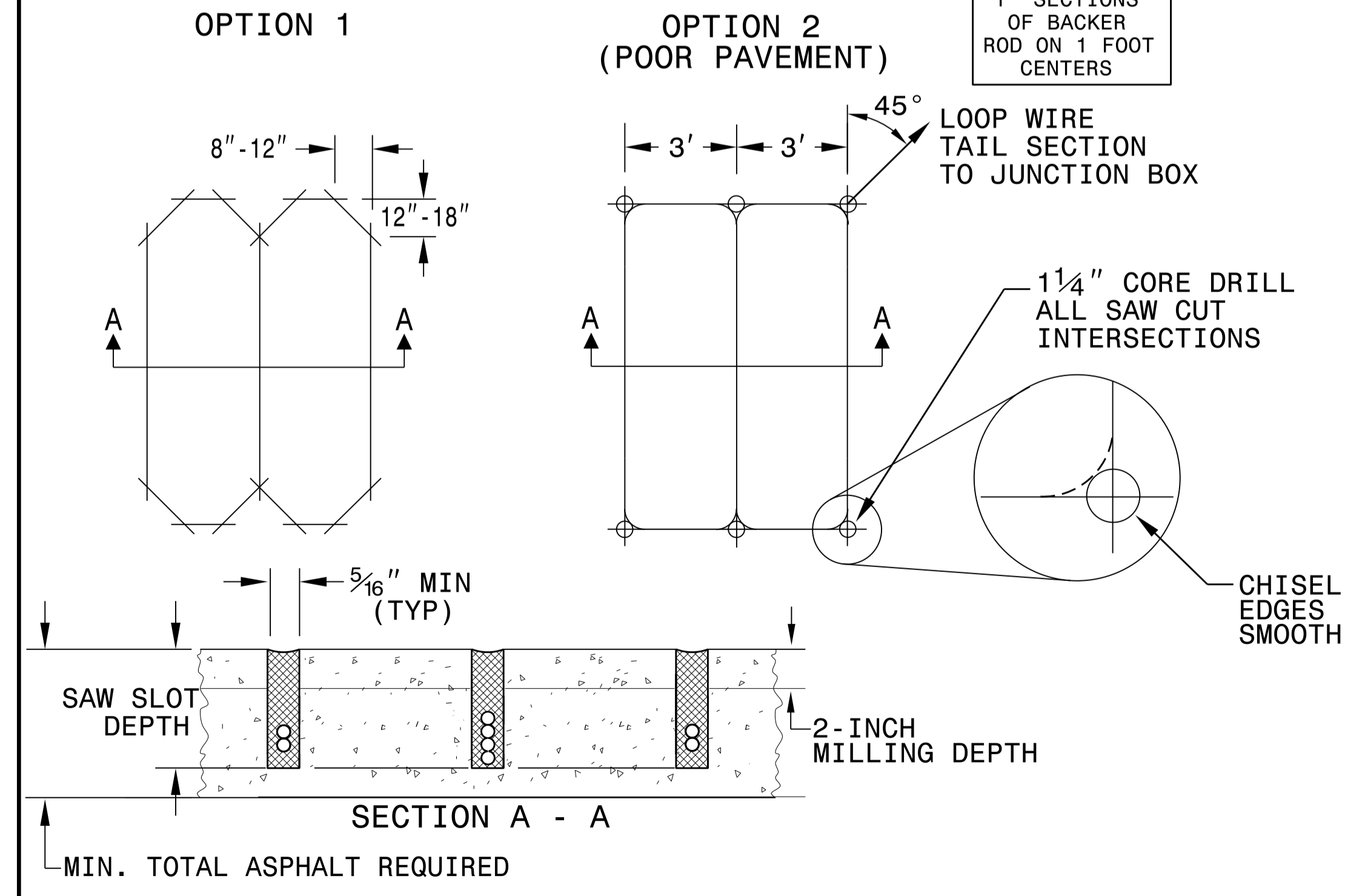

**LOOP WINDING METHOD**

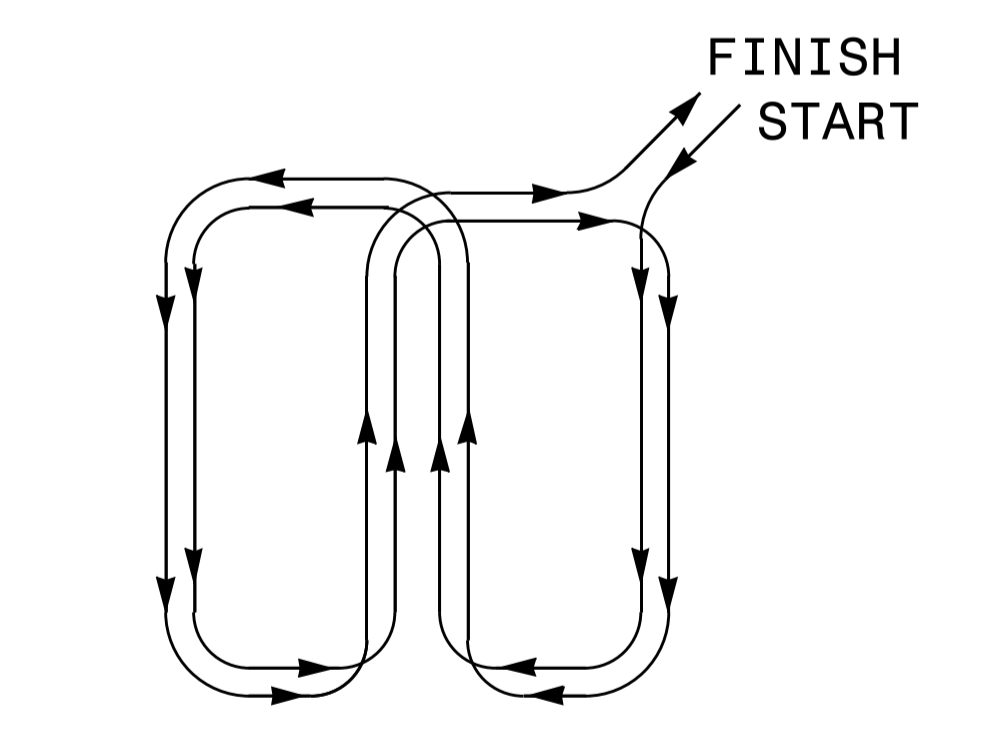

**REVISIONS**

1. REMOVED TWISTING NOTES FROM TAIL SECT. TO JUNCTION BOX. 2/26/08 MWH
2. REVISED SECTION A - A DETAILS. 6/29/15 JTP

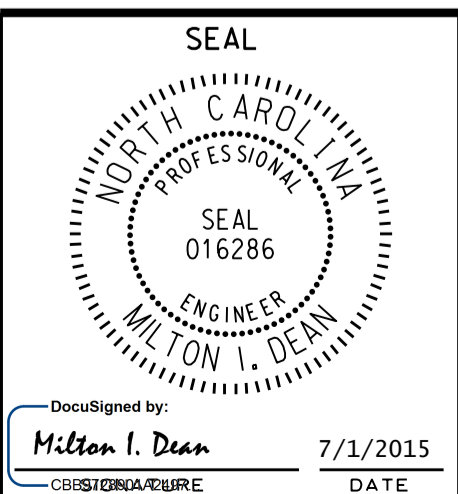
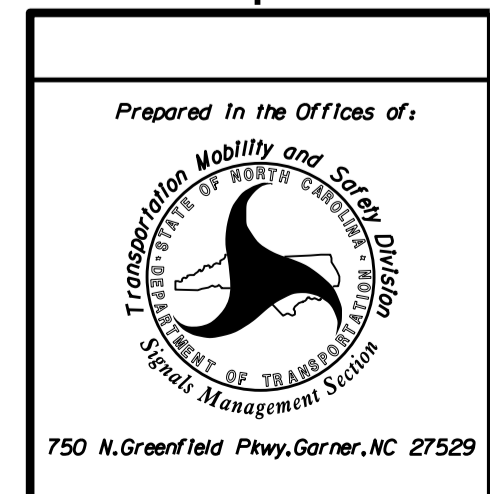

SHEET 1 OF 1

ENGLISH STANDARD DRAWING FOR  
**DEEP-CUT INDUCTIVE DETECTION LOOPS**  
(FOR INSTALLATION PRIOR TO MILLING)

STATE OF NORTH CAROLINA  
DEPT. OF TRANSPORTATION  
DIVISION OF HIGHWAYS  
RALEIGH, N.C.