

NOTES

STIRRUPS IN CAP MAY BE SHIFTED AS NECESSARY TO CLEAR DOWELS.

FIELD BEND #4 B4 & #4 B5 AS NECESSARY TO MAINTAIN REQUIRED CONCRETE COVER.

★ INVERT ALTERNATE STIRRUPS.

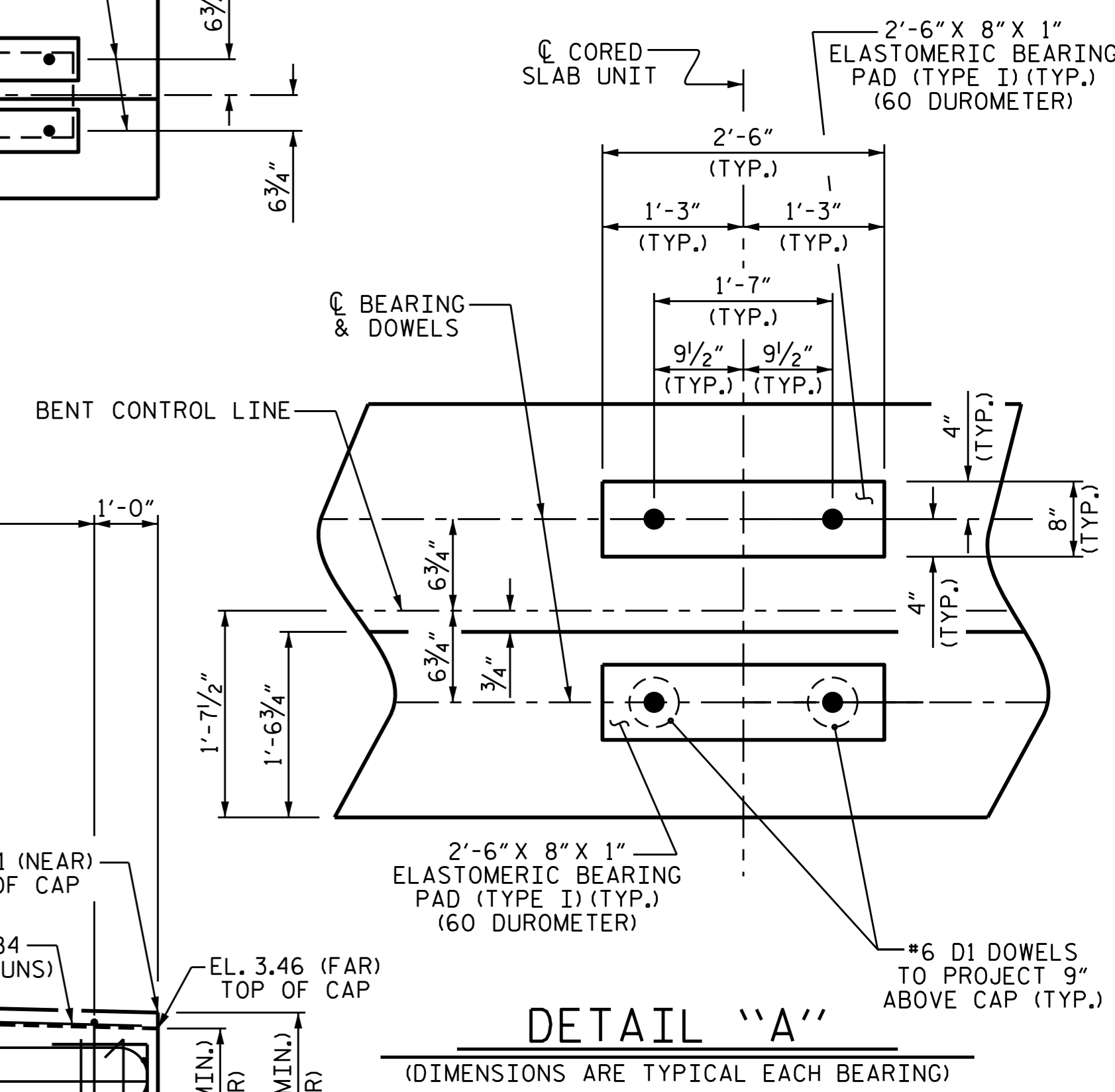
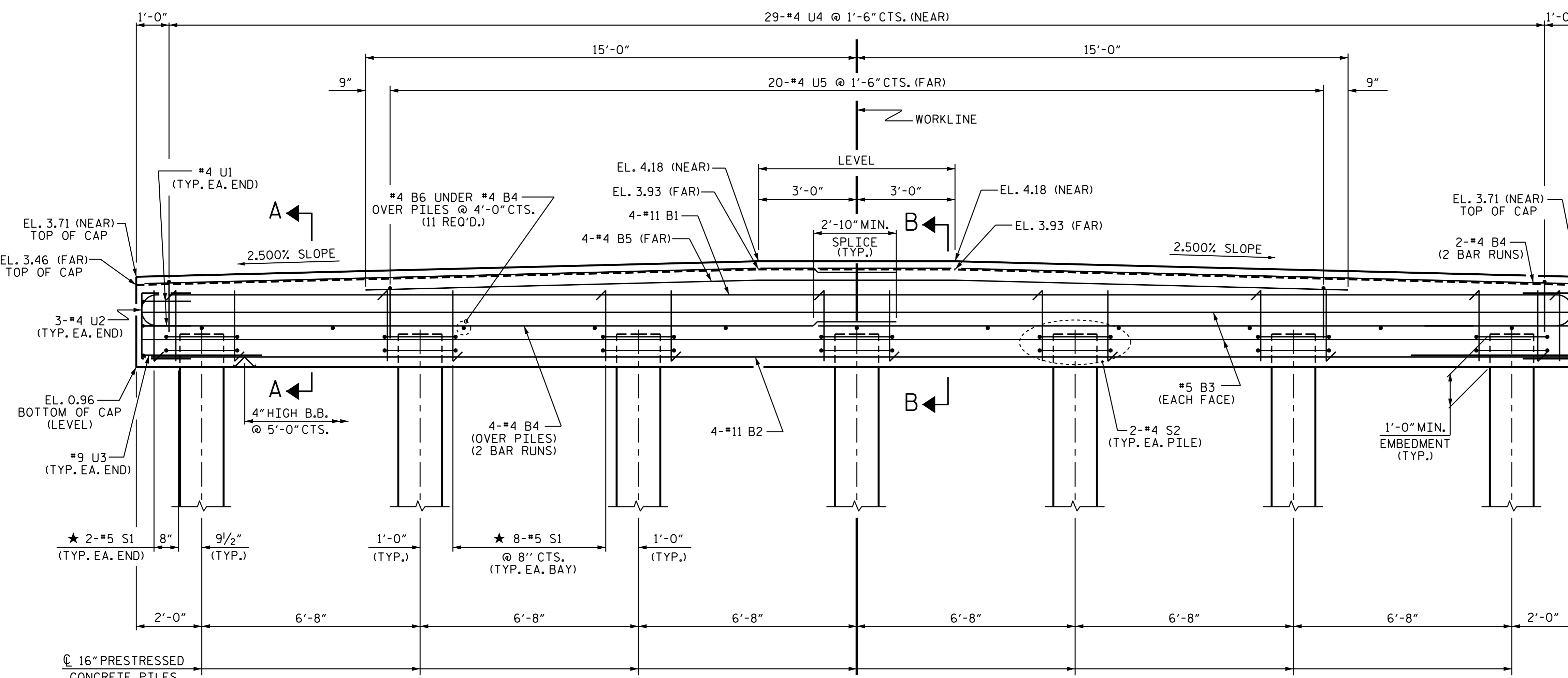
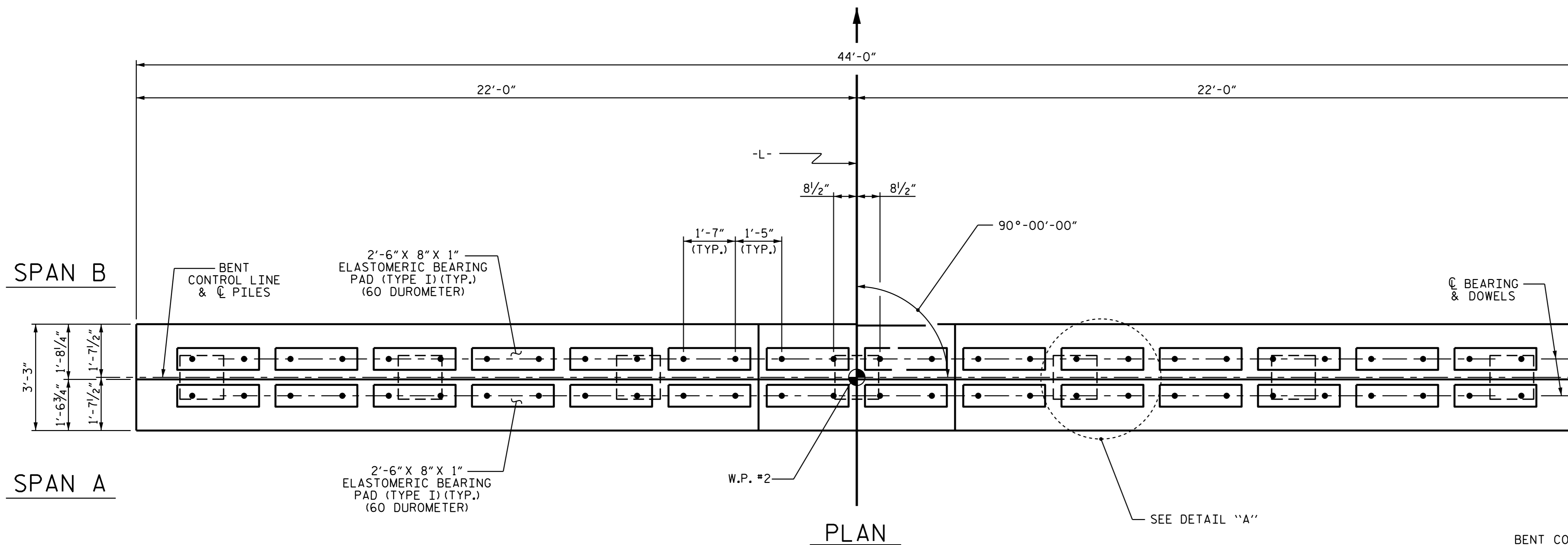

PROJECT NO. B-5300
 BEAUFORT COUNTY
 STATION: 18+77.50 -L-

SHEET 1 OF 2

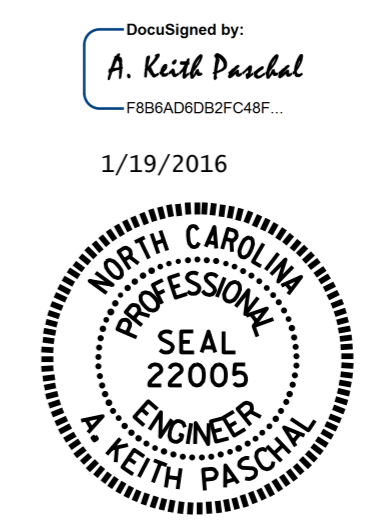

STATE OF NORTH CAROLINA
 DEPARTMENT OF TRANSPORTATION
 RALEIGH

**SUBSTRUCTURE
 BENT 1**

DRAWN BY: K. P. SEDAI DATE: 7/13/15
 CHECKED BY: P. N. HOLDER DATE: 9/8/15
 DESIGN ENGINEER OF RECORD: P. N. HOLDER DATE: 9/8/15

ELEVATION
 FOR SECTION A-A & B-B SEE SHEET 2 OF 2

DOCUMENT NOT CONSIDERED FINAL UNLESS ALL SIGNATURES COMPLETED

REVISIONS						SHEET NO. S-21 TOTAL SHEETS 30
NO.	BY:	DATE:	NO.	BY:	DATE:	
1			3			
2			4			