

# PROJECT TYPICAL FORCE MAIN DETAILS

PREPARED IN THE OFFICE OF:

**THE WOOTEN COMPANY**  
ENGINEERING | PLANNING | ARCHITECTURE  
120 North Robin Avenue, Raleigh, NC 27603-1423  
919.862.8111 | www.thewooten.com  
License Number: F-015

PROJECT REFERENCE NO. **B-5300**

SHEET NO. **UC-3B**

DESIGNED BY: JRG  
DRAWN BY: TK  
CHECKED BY: JRG  
APPROVED BY: MDS

REVIS: NORTH CAROLINA DEPARTMENT OF TRANSPORTATION

UTILITIES ENGINEERING SEC. PHONE: (919) 707-6690 FAX: (919) 250-4151

Document Not Considered Final Unless All Signatures Completed

UTILITY CONSTRUCTION PLANS ONLY

## UTILITY CONSTRUCTION

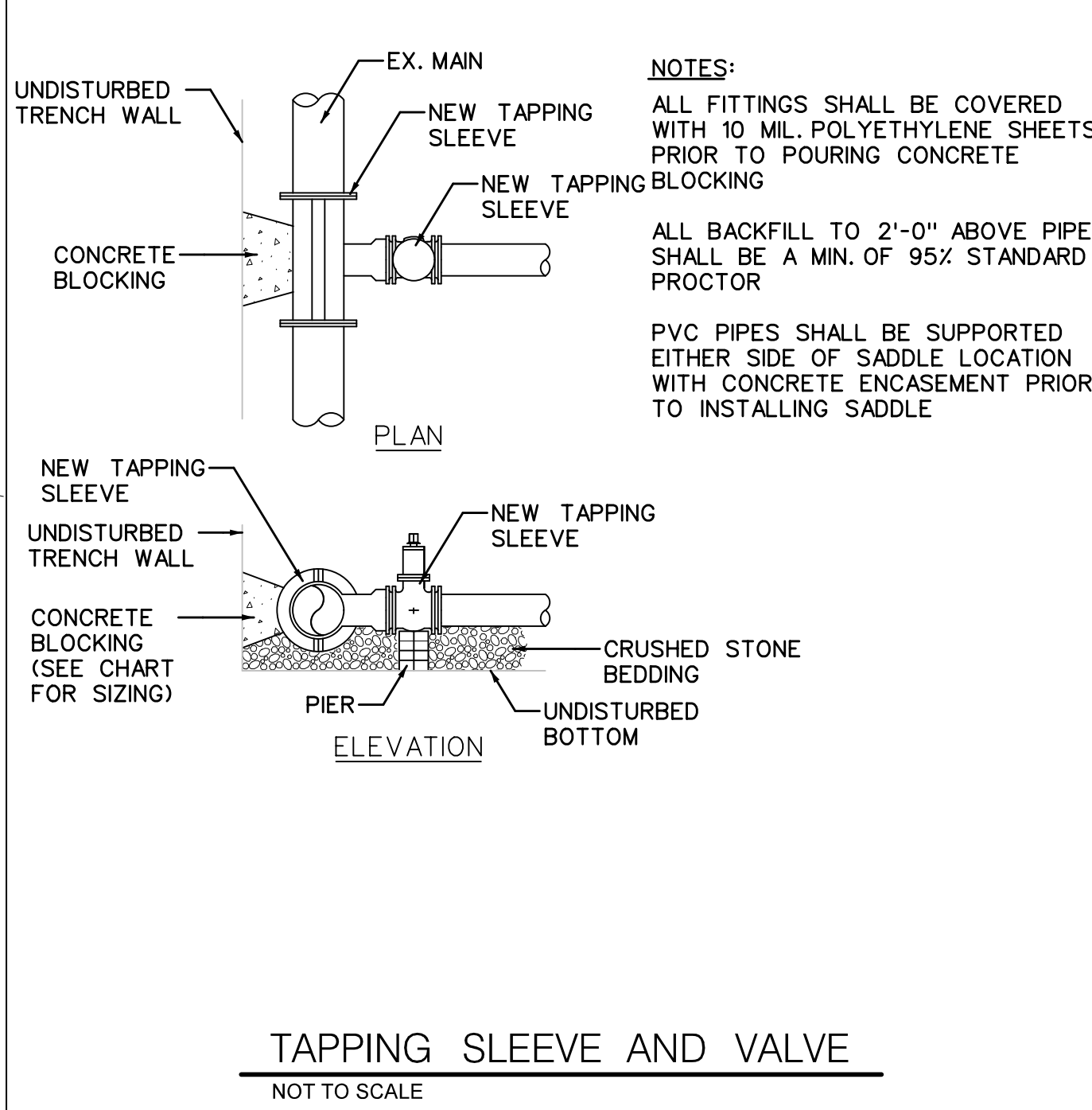
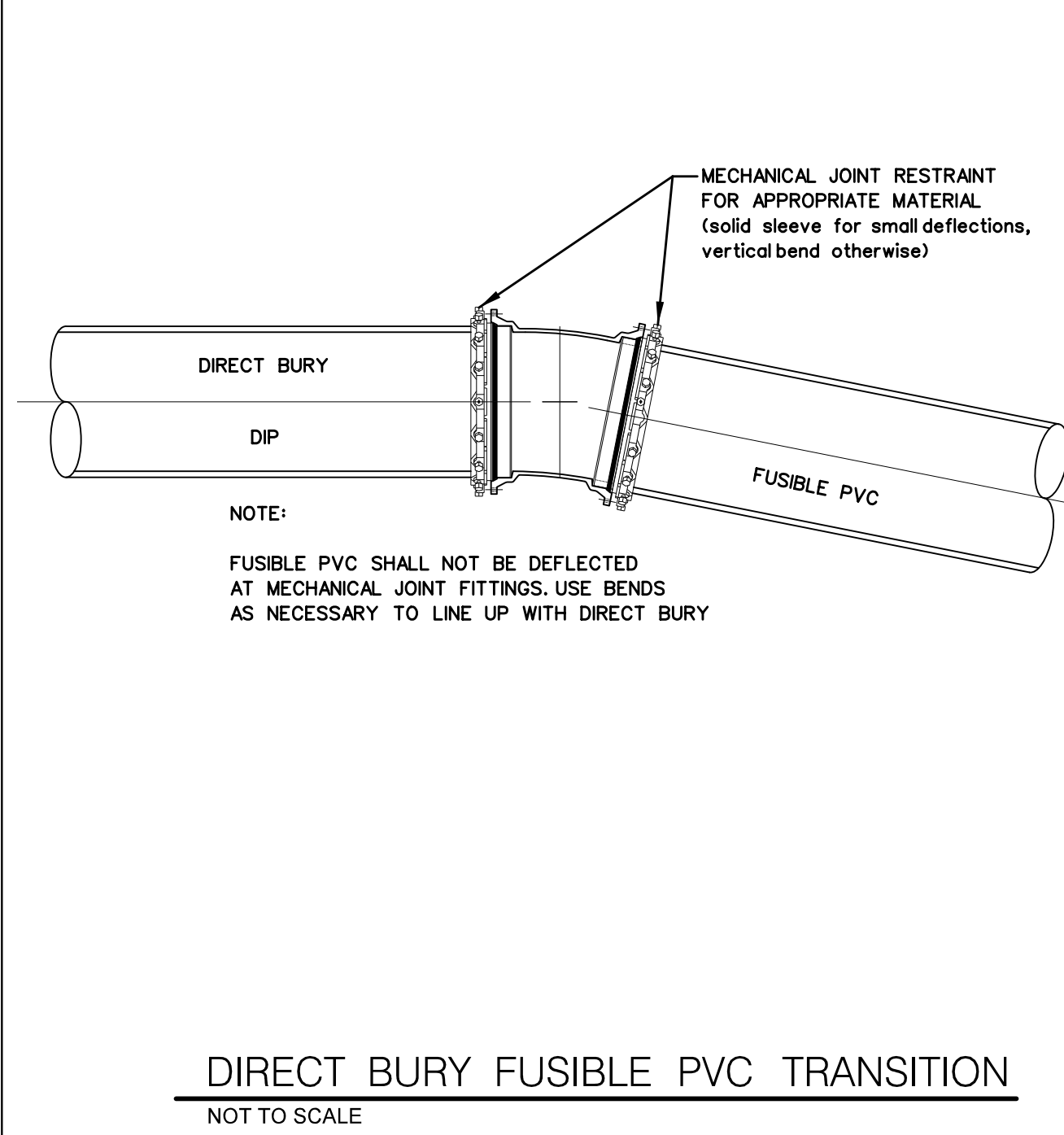
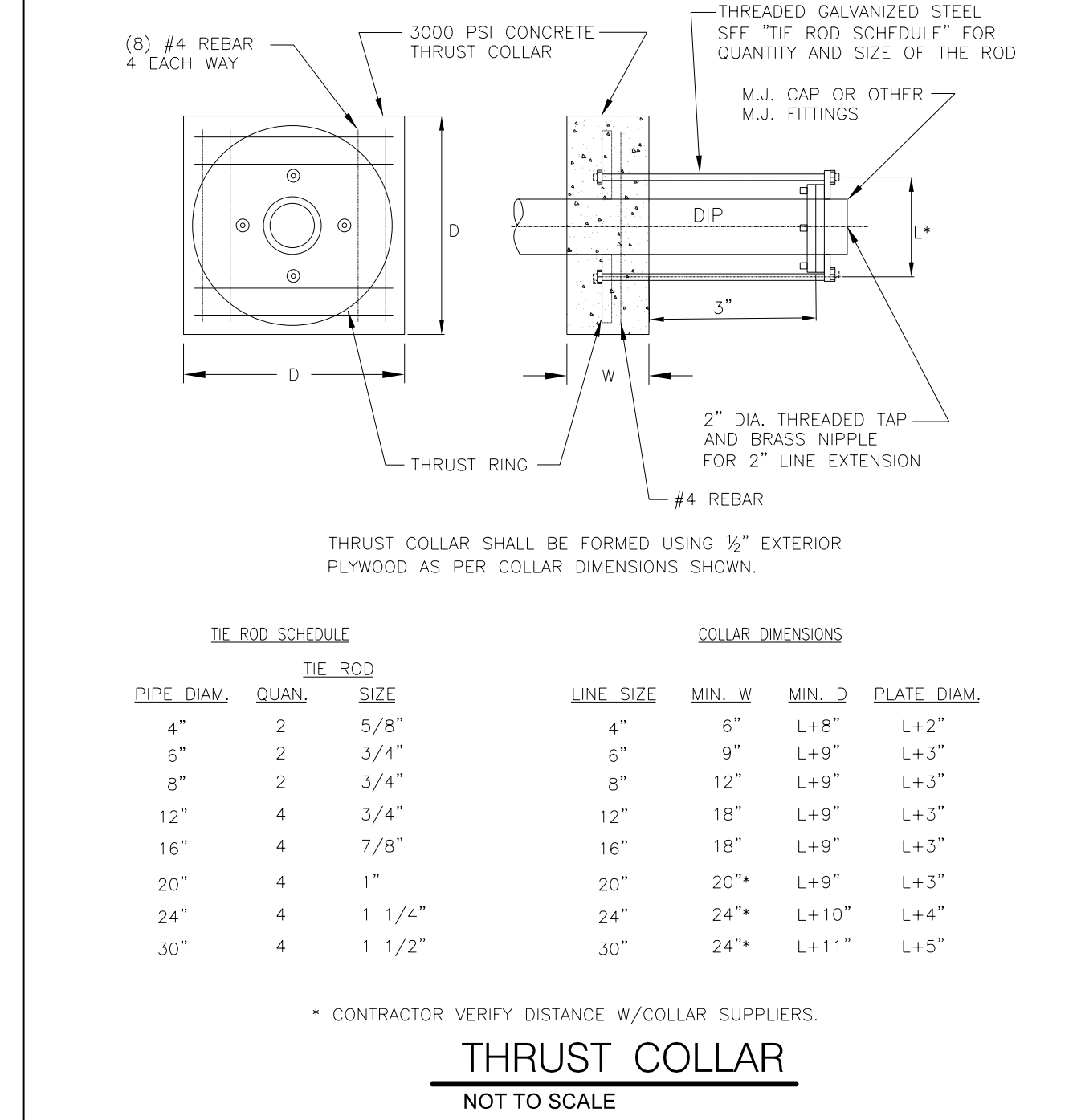
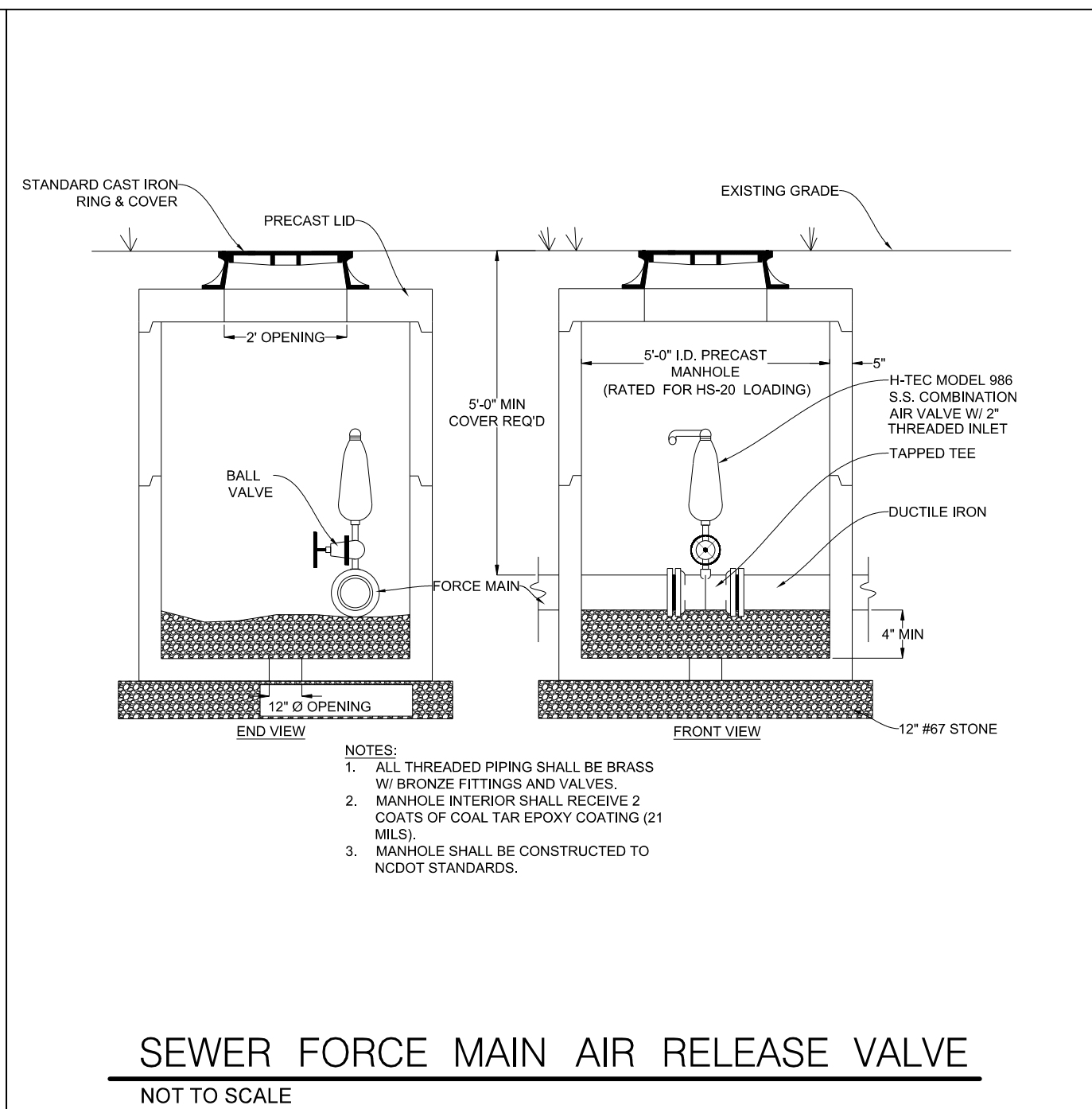
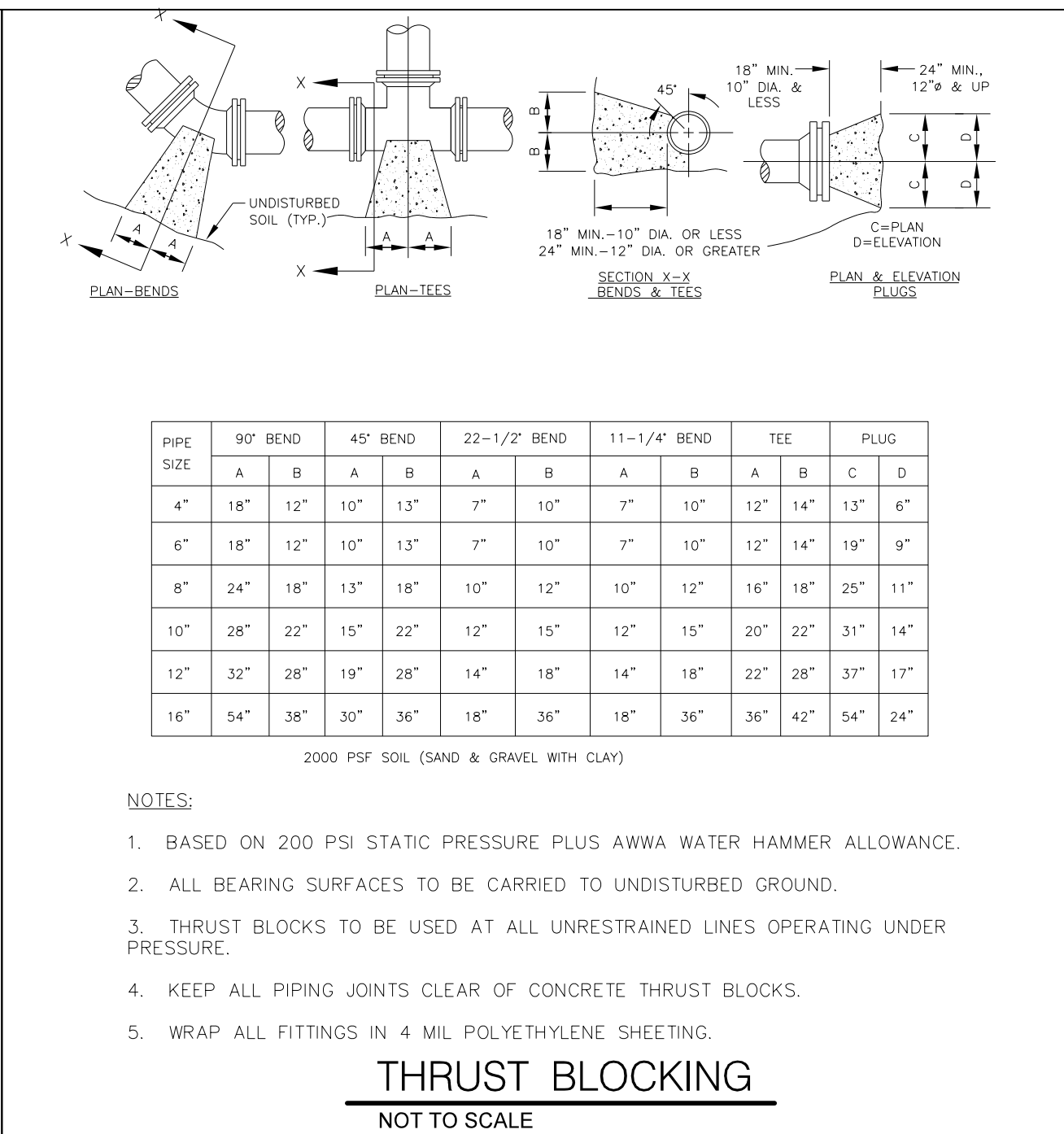
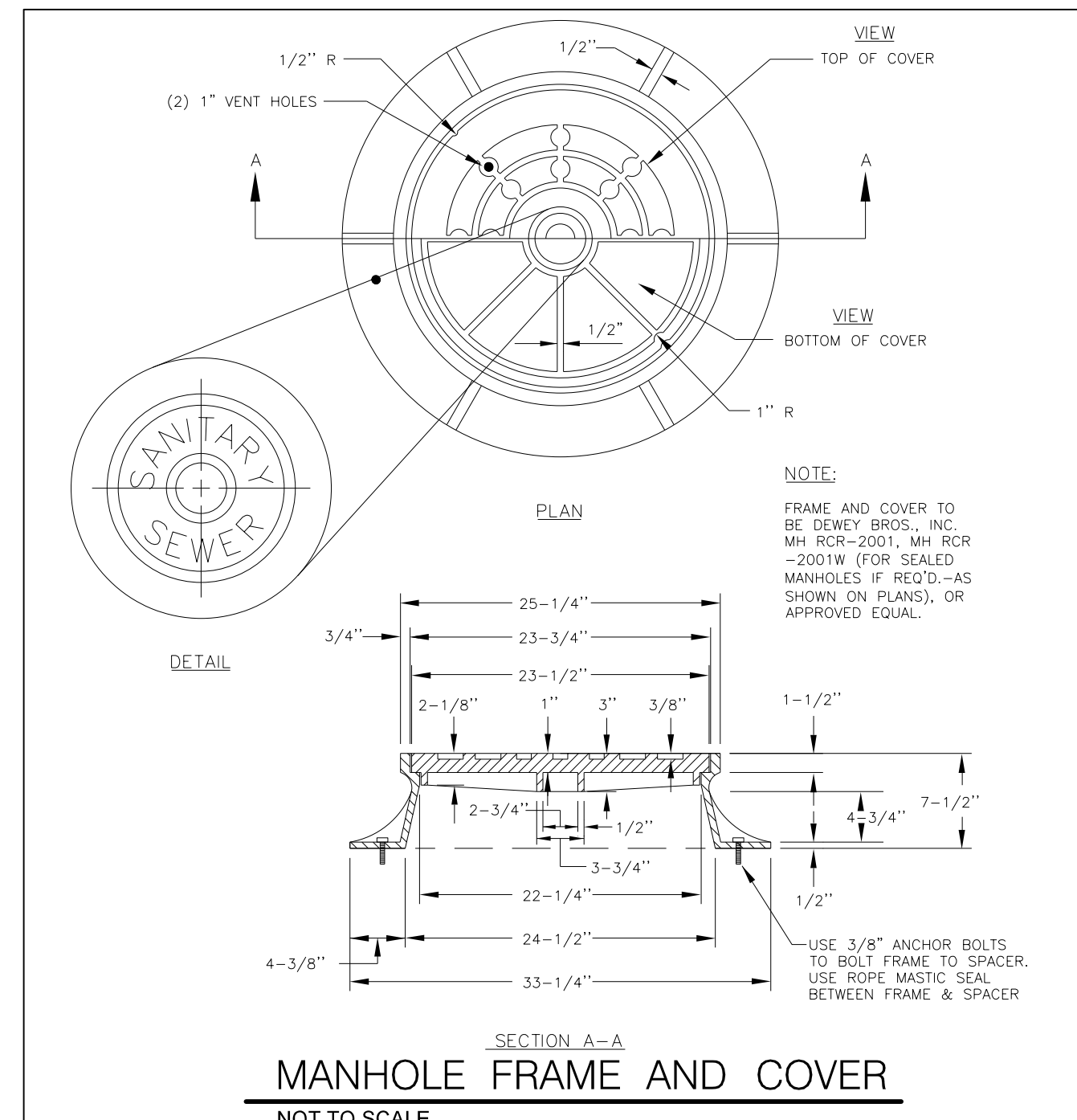

**METHOD OF PIPE INSTALLATION**  
NOT TO SCALE

RIGID PIPE					FLEXIBLE PIPE				
Disaster	Minimum cover (feet)	Minimum weight of cover (lb/ft)	Minimum weight of cover (kg/ft)	Minimum weight of cover (lb/ft)	Minimum weight of cover (kg/ft)	Minimum weight of cover (lb/ft)	Minimum weight of cover (kg/ft)	Minimum weight of cover (lb/ft)	Minimum weight of cover (kg/ft)
12	12	100	200	100	200	100	200	100	200
18	12	100	200	100	200	100	200	100	200
24	12	100	200	100	200	100	200	100	200
30	12	100	200	100	200	100	200	100	200
36	12	100	200	100	200	100	200	100	200
42	12	100	200	100	200	100	200	100	200
48	12	100	200	100	200	100	200	100	200
54	12	100	200	100	200	100	200	100	200
60	12	100	200	100	200	100	200	100	200
66	12	100	200	100	200	100	200	100	200
72	12	100	200	100	200	100	200	100	200

5/14/2015